

C35L-XX

High Power LED

Introduction

The C35L-XX LED from SemiLEDs brings industry leading technology to the solid state lighting market with its high quality and performance. With a silicone lens, C35L-XX LEDs from SemiLEDs feature very high brightness and efficacy, as well as excellent lifetime.

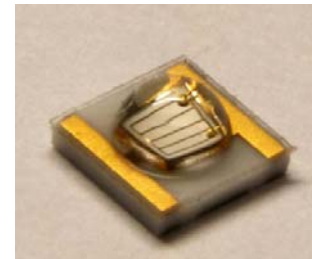

C35L-XX LEDs also feature a special design to fit secondary optics for various lighting applications. The user can easily get uniform light with any secondary optics.

Table of Contents

Characteristics	1
Relative Spectral Power Distribution	4
Typical Light Output Characteristics vs. Temperature	5
Typical Spatial Radiation Pattern	6
Thermal Design	9
Typical Forward L-I Characteristics	10
Typical Forward I-V Characteristics	11
Mechanical Dimensions	12
Recommended Solder Pad Design	13
Packing Information	14
Recommended Soldering Profile	15
Reliability	16

RoHS Compliant

Characteristics

Absolute Ratings

Parameter	Rating
	White / Royal Blue / Blue / Green / Cyan / Amber / Red
DC Forward Current (mA)	700 mA
LED Junction Temperature	125°C
LED Operating Temperature	-40°C~125°C
Storage Temperature	-40°C~125°C
Soldering Temperature	Max. 260°C / Max. 10sec. (JEDEC 020c)
ESD Sensitivity	2,000 V HBM (JESD-22A-114-B)
Reverse Voltage	Not design to be driven in reverse bias (VR ≤ 5V)
Preconditioning	Acc. to JEDEC Level 2

General Characteristics at 350mA

Part number	Color	Dominant Wavelength λ_d Peak Wavelength λ_p * Correlated Color Temperature, CCT		$2\theta_{1/2}$	Temperature Coefficient of Vf (mV/°C)	Thermal Resistance Junction to Pad
		Min	Max			
C35L-W0	Daylight	4750K	10000K	135	-3	8
C35L-W1	Neutral White	3700K	4750K	130	-3	8
C35L-W7	Warm White	2600K	3700K	130	-3	8
C35L-RN	Red	620	635	125	-	-
C35L-AN	Amber	580	600	125	-	-
C35L-GN	Green	520	535	125	-3	8
C35L-CN	Cyan	500	520	125	-3	8
C35L-BN	Blue	460	470	125	-3	8
C35L-DN	Royal Blue	440	460*	125	-3	8

Notes:

- The peak/dominant wavelength is measured with an accuracy of $\pm 1\text{nm}$.
- SemiLEDs maintains a tolerance of ± 2 on CRI measurements.
Typical CRI for Cool White (4750 K – 10,000 K CCT) is 70.
Typical CRI for Neutral White (3700 K – 4750 K CCT) is 75.
Minimum CRI for Warm White (2600 K – 3700 K CCT) is 80.

Luminous Flux and Forward Voltage

Part number	Color	Performance at Test Current (350mA)				Performance at 700mA
		Group	Minimum Luminous Flux (lm) or Radiometric Power* (mW)	VF		Typical Luminous Flux (lm) or Radiometric Power* (mW)
				Min	Max	
C35L-W0	Daylight	RB	114	2.8	3.6	200
		RC	122	2.8	3.6	215
		RD	130	2.8	3.6	225
		RE	139	2.8	3.6	240
		SB	148	2.8	3.6	255
C35L-W1	Neutral White	QE	107	2.8	3.6	180
		RB	114	2.8	3.6	200
		RC	122	2.8	3.6	214
		RD	130	2.8	3.6	225
C35L-W7	Warm White	PD	80.6	2.8	3.6	145
		QB	87.4	2.8	3.6	150
		QC	93.9	2.8	3.6	163
		QD	100	2.8	3.6	168
		QE	107	2.8	3.6	180

Part number	Color	Performance at Test Current (350mA)				Performance at 700mA
		Group	Minimum Luminous Flux (lm) or Radiometric Power* (mW)	VF		Typical Luminous Flux (lm) or Radiometric Power* (mW)
				Min	Max	
C35L-RN	Red	NB	51.7	2	3	96
		NC	56.8	2	3	105
C35L-AN	Amber	NB	51.7	2	3	96
		NC	56.8	2	3	105
C35L-GN	Green	PC	73.9	2.8	3.6	130
		PD	80.6	2.8	3.6	142
		QB	87.4	2.8	3.6	154
C35L-CN	Cyan	PC	73.9	2.8	3.6	130
		PD	80.6	2.8	3.6	142
		QB	87.4	2.8	3.6	154
C35L-BN	Blue	JC	23.5	2.8	3.6	43
		KB	30.6	2.8	3.6	56
C35L-DN	Royal Blue	E1	400*	2.8	3.6	712*
		E2	440*	2.8	3.6	783*
		E3	480*	2.8	3.6	850*

Note:

1. Luminous flux is measured with an accuracy of $\pm 10\%$.
2. The forward voltage is measured with an accuracy of $\pm 0.1V$.

Relative Spectral Power Distribution, Ta=25 °C

White light

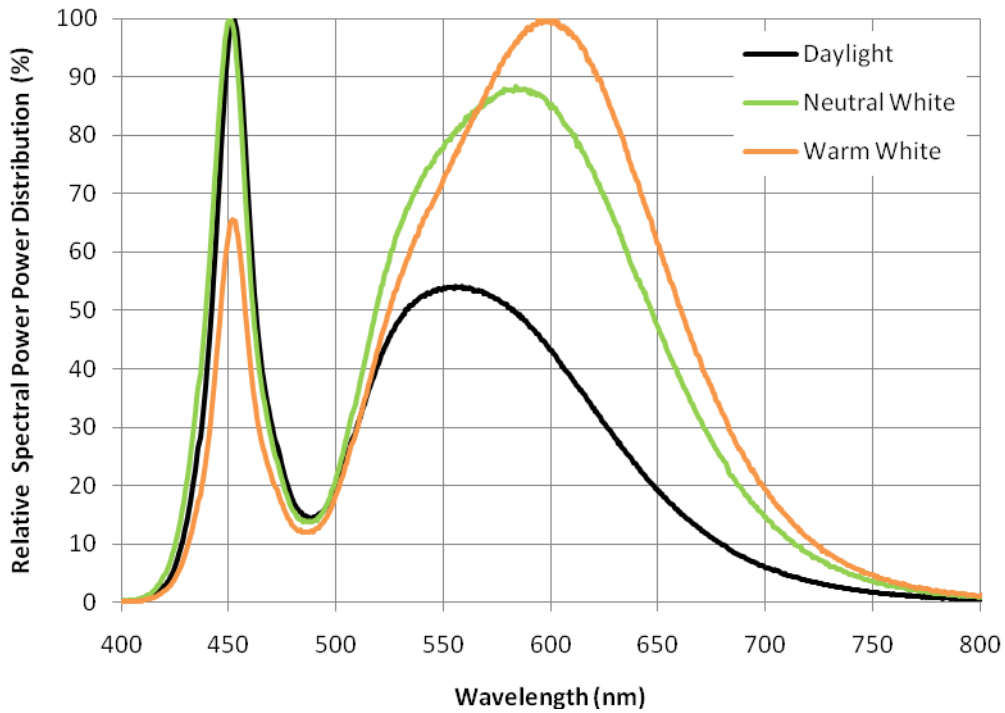

Royal Blue / Blue / Cyan / Green / Amber / Red

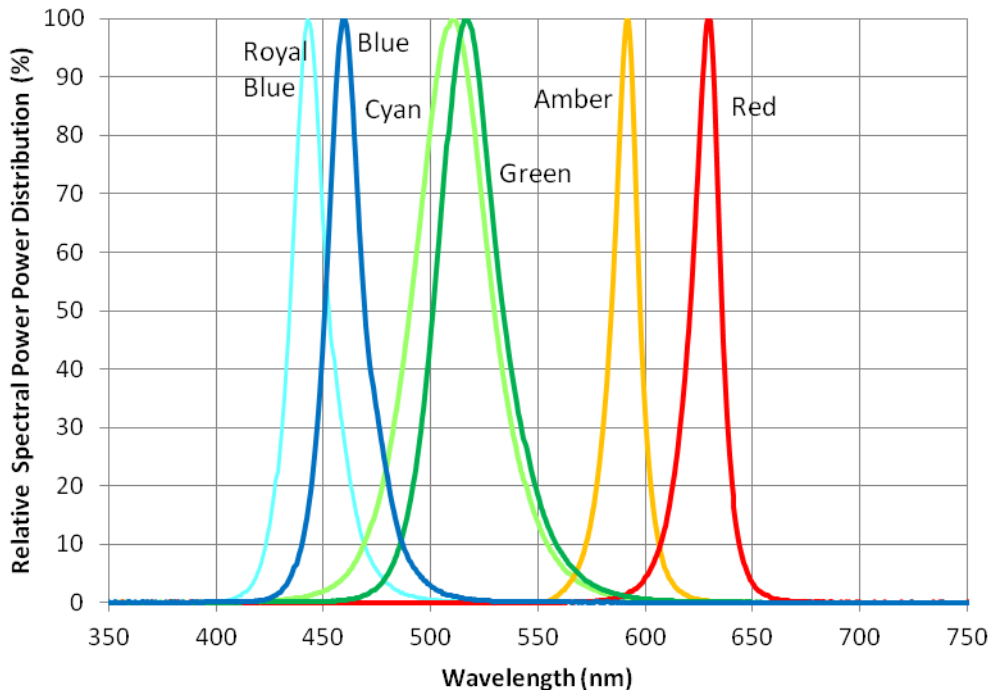

Typical Light Output Characteristics Vs. Temperature

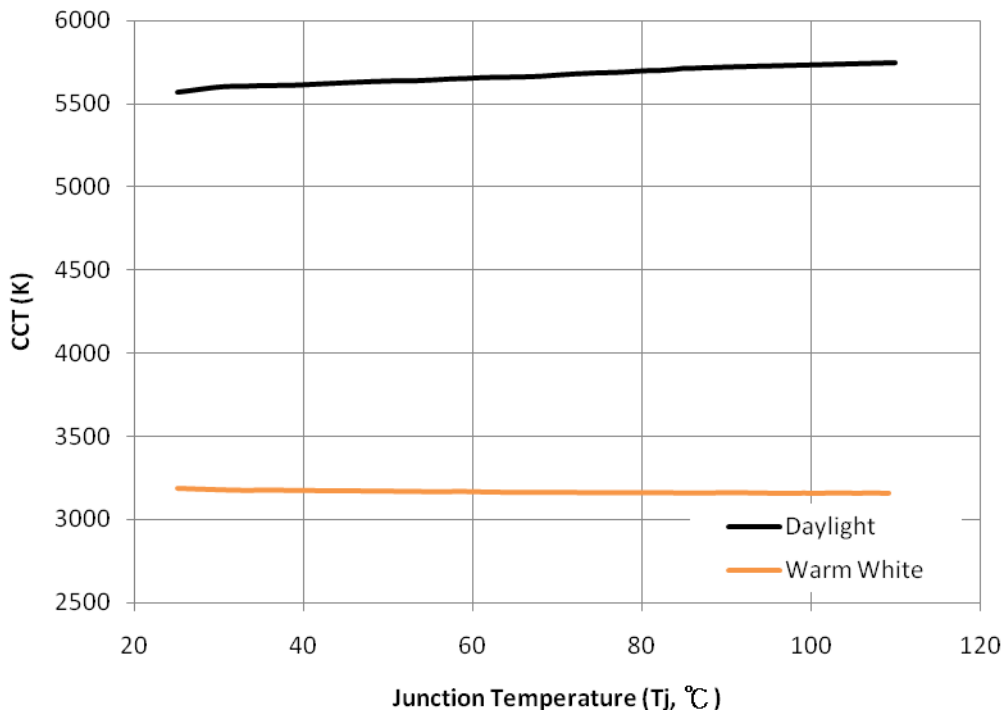
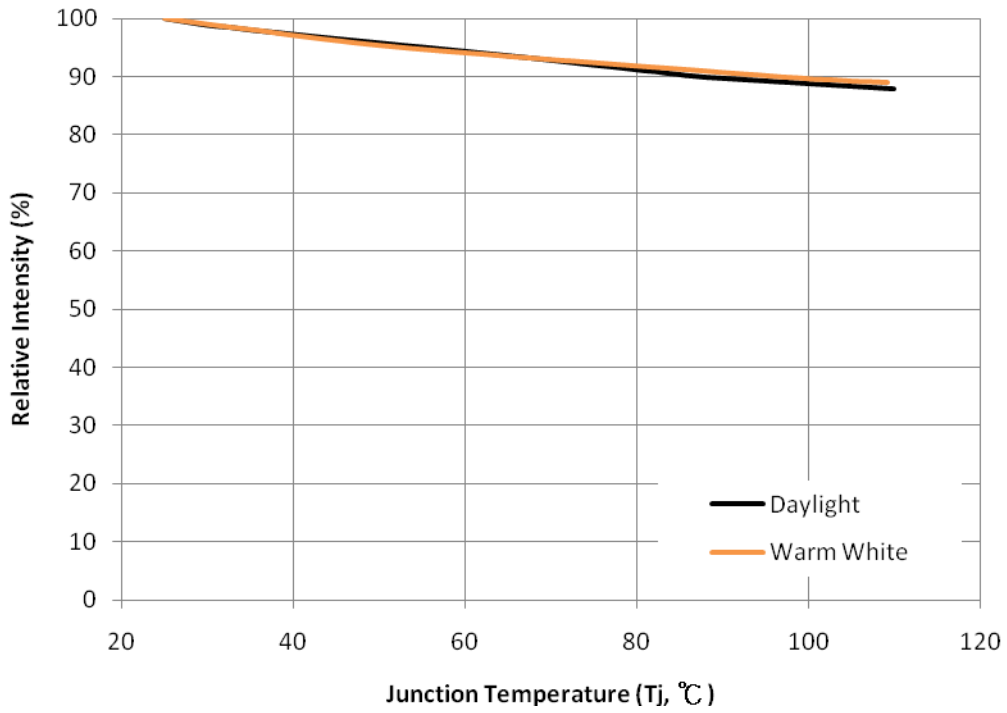

Typical Spatial Radiation Pattern

C35L-W0 Daylight

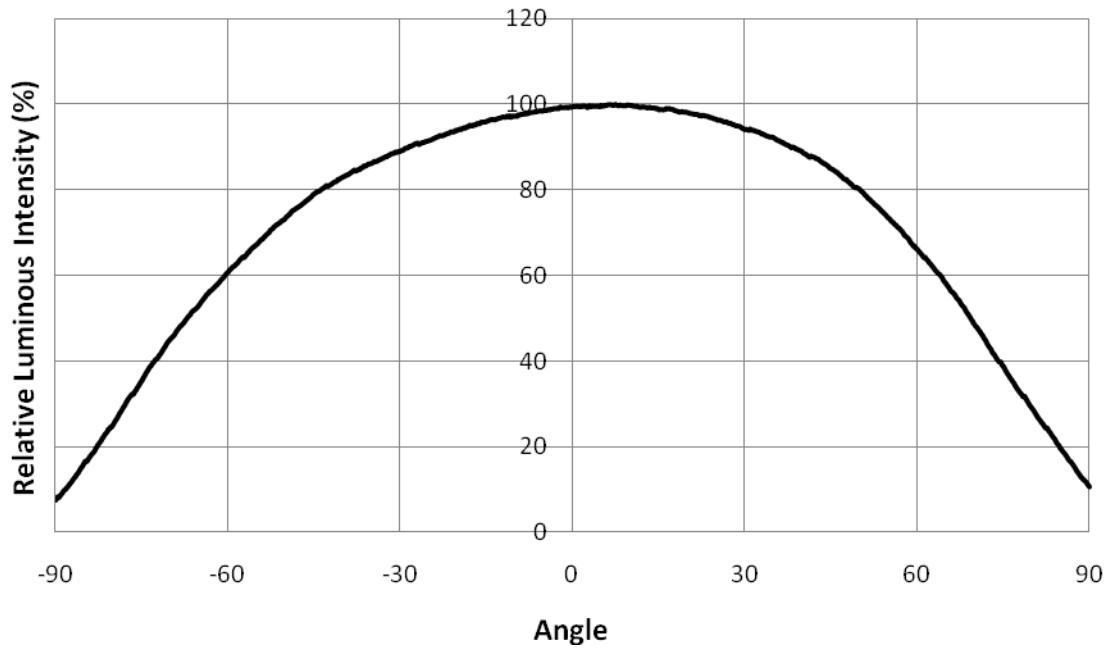

C35L-W1 Neutral White

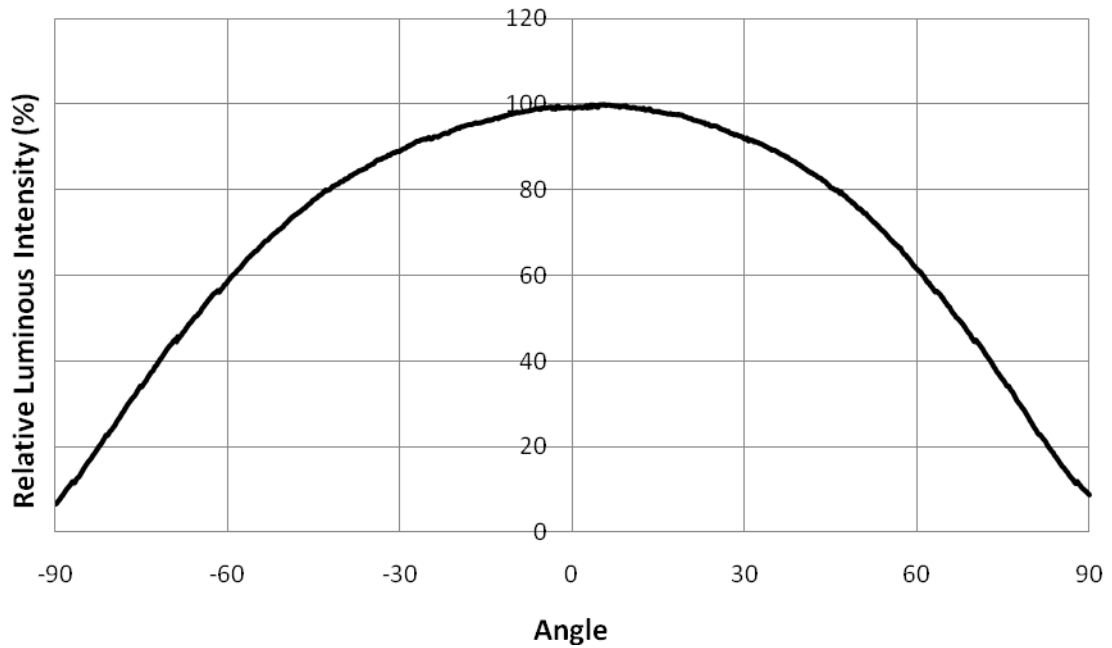

C35L-W7 Warm White

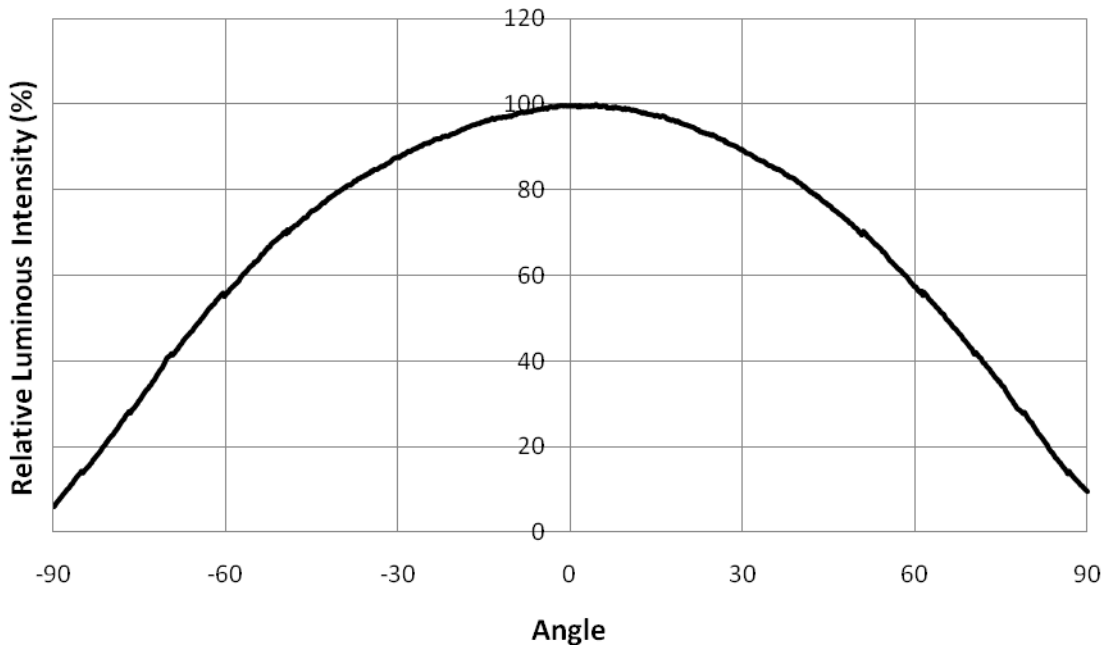

C35L-DN, C35L-BN

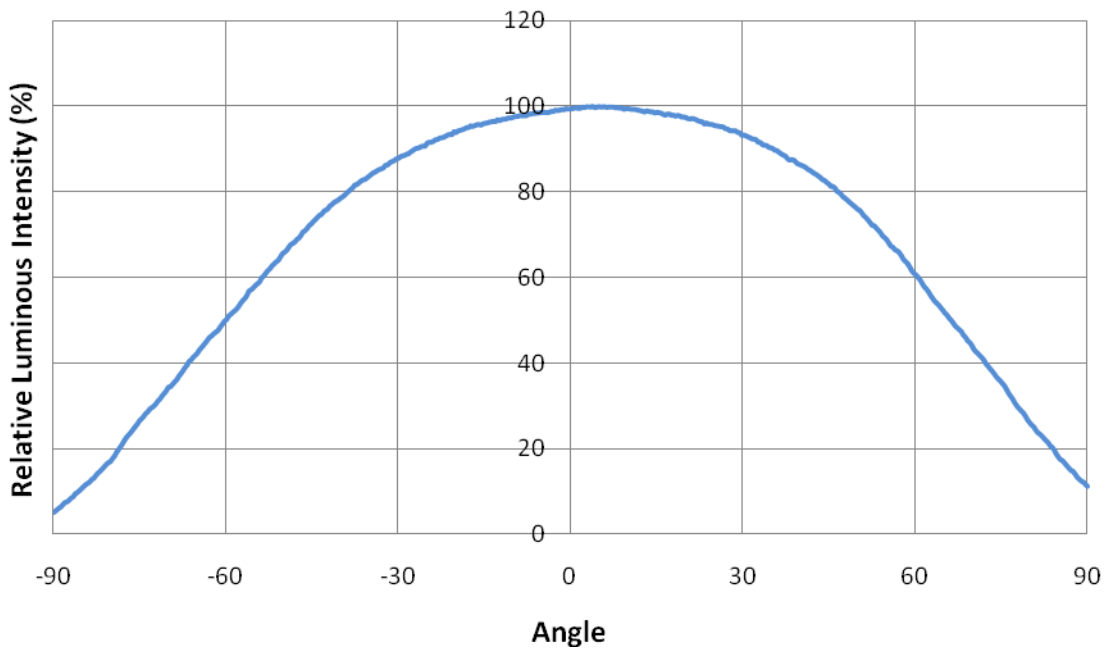

C35L-GN, C35L-CN

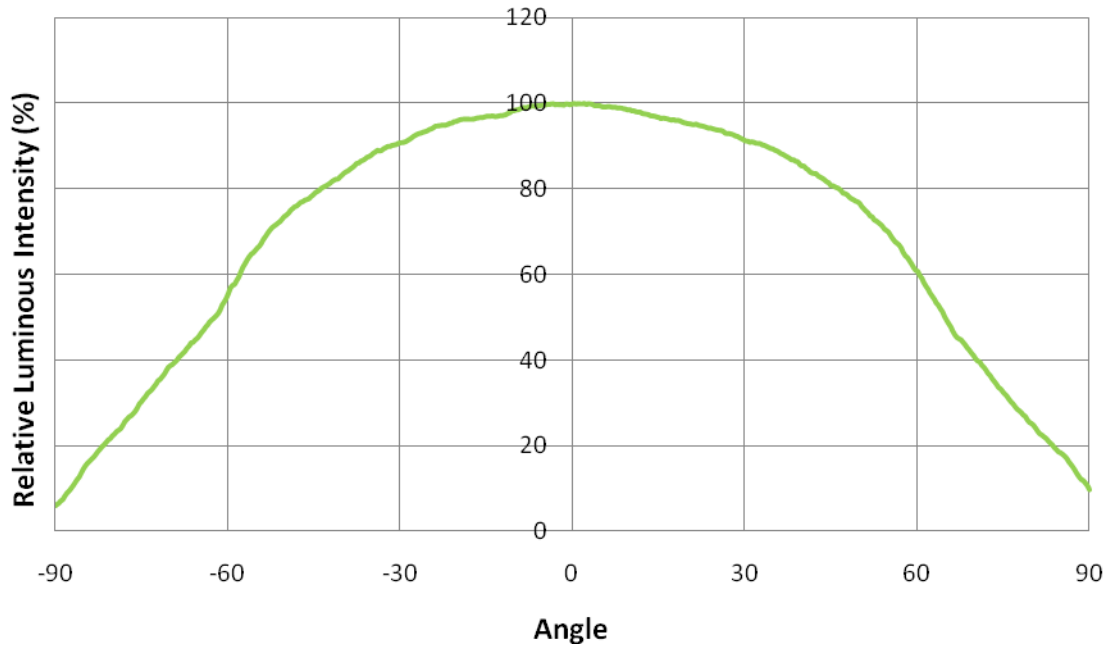

C35L-AN, C35L-RN

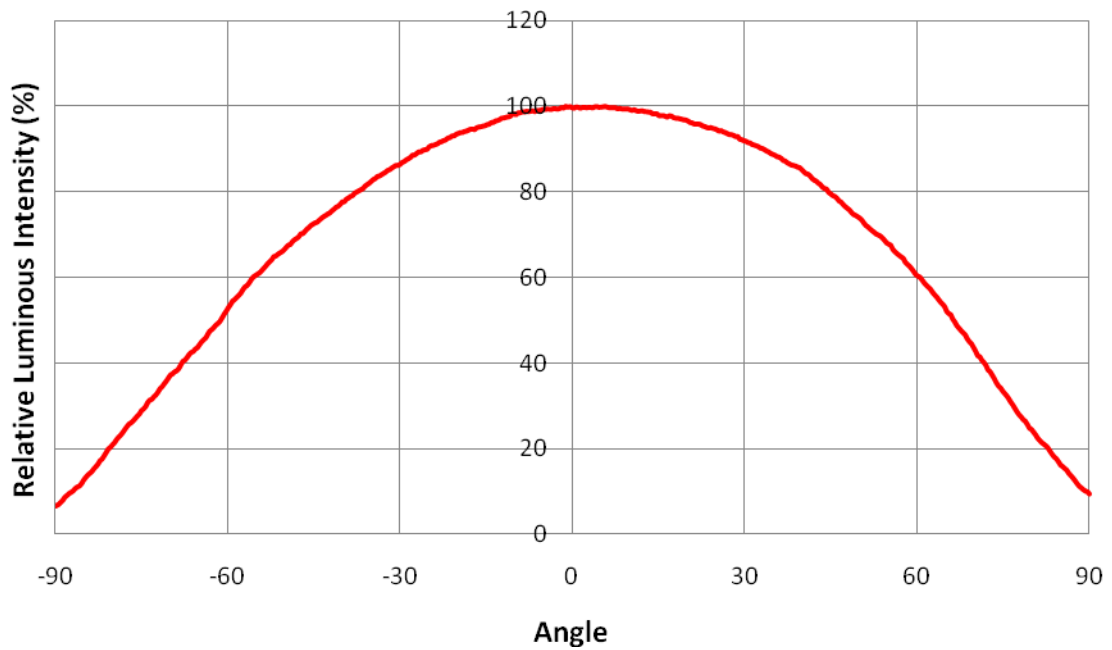

Thermal Design

Thermal design of the end product is important. The thermal resistance between the junction and the solder point ($R_{\Theta_{J-P}}$) is $8^{\circ}\text{C}/\text{W}$, and the end product should be designed to minimize the thermal resistance from the solder point to ambient in order to optimize the emitter life and optical characteristics. The maximum operation current is determined by the plot of Allowable Forward Current vs. Ambient Temperature.

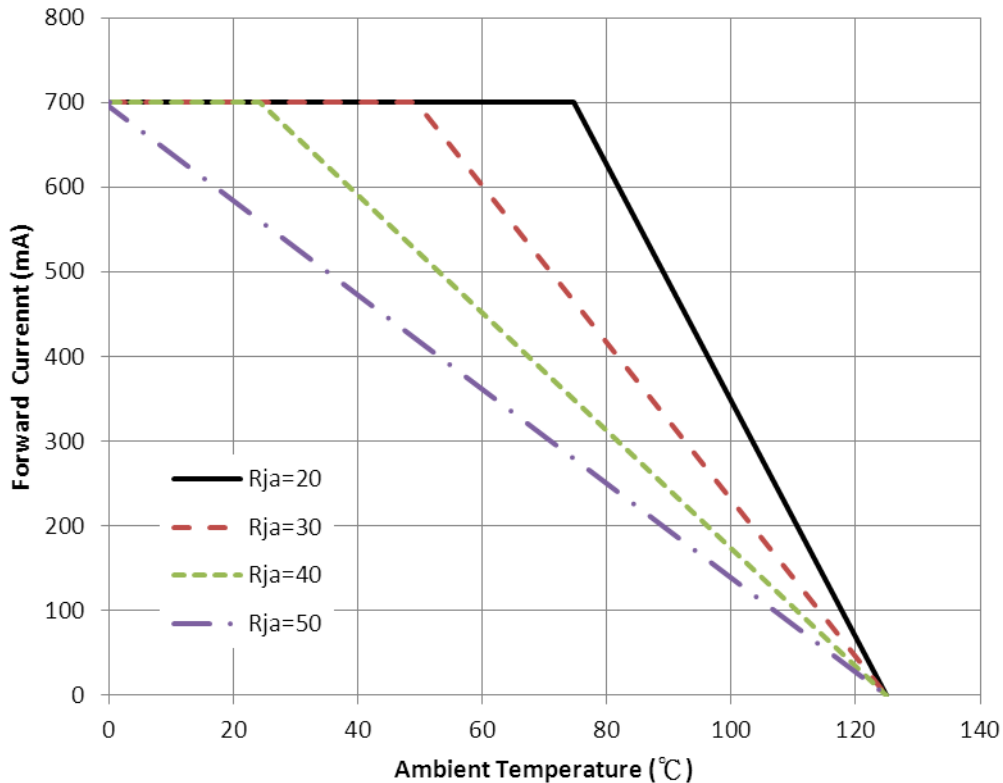

The junction temperature can be correlated to the thermal resistance between the junction and ambient (R_{ja}) by the following equation.

$$T_j = T_a + R_{ja} * W$$

T_j : LED junction temperature

T_a : Ambient temperature

R_{ja} : Thermal resistance between the junction and ambient

W : Input power ($I_F * V_F$)

Typical Forward L-I Characteristics

White Series / Blue / Royal Blue / Green / Cyan

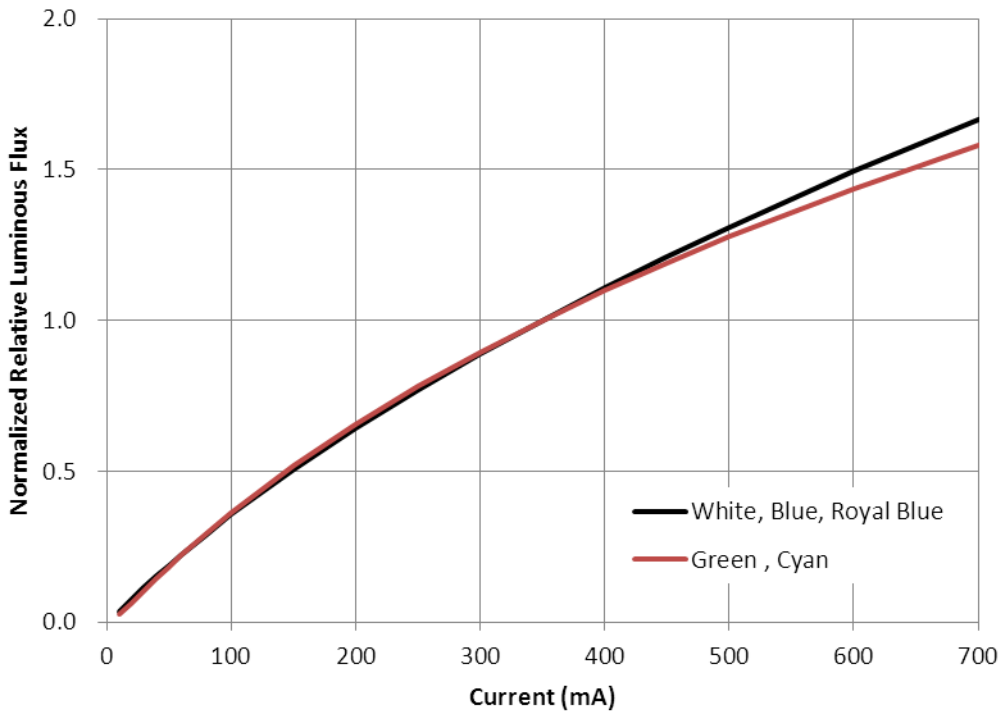

Amber / Red

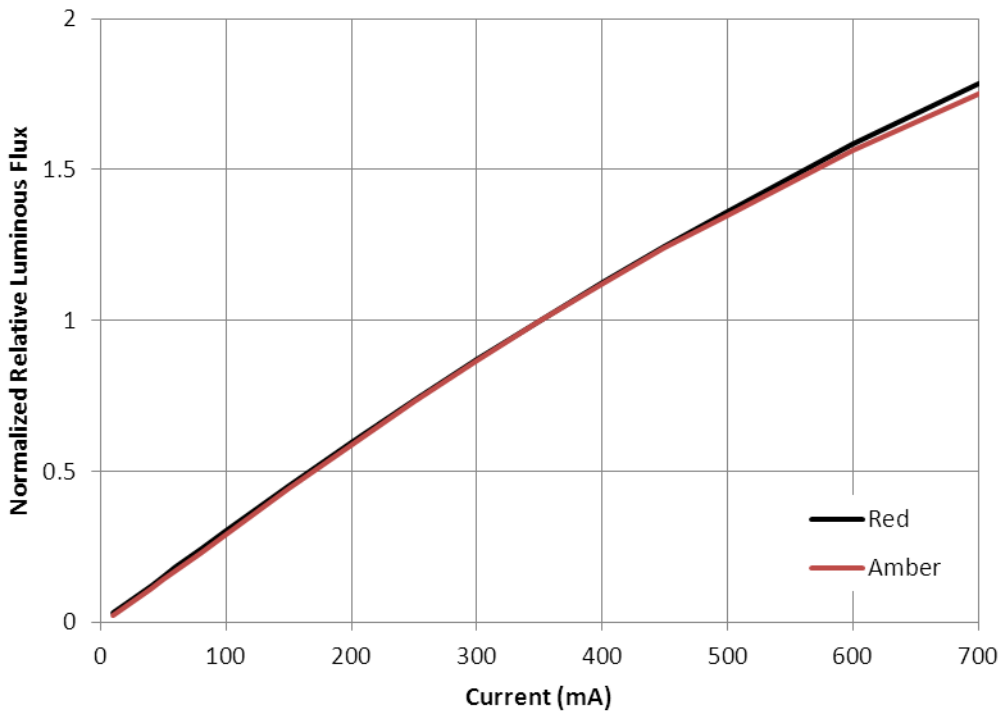

Typical Forward I-V Characteristics

White Series / Blue / Royal Blue / Green / Cyan

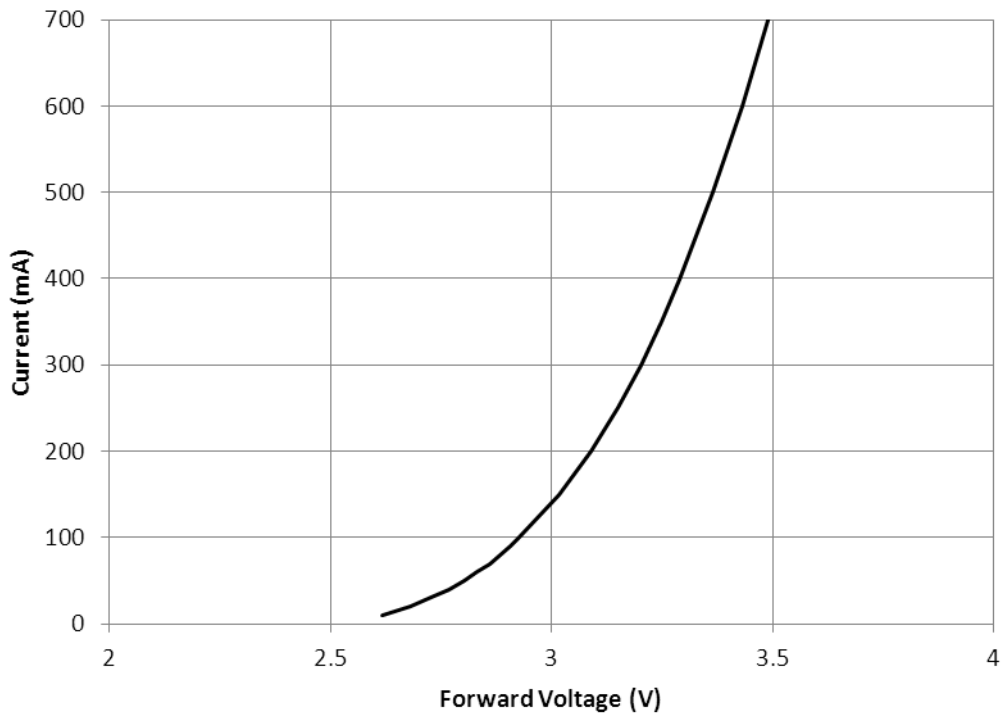

Amber / Red

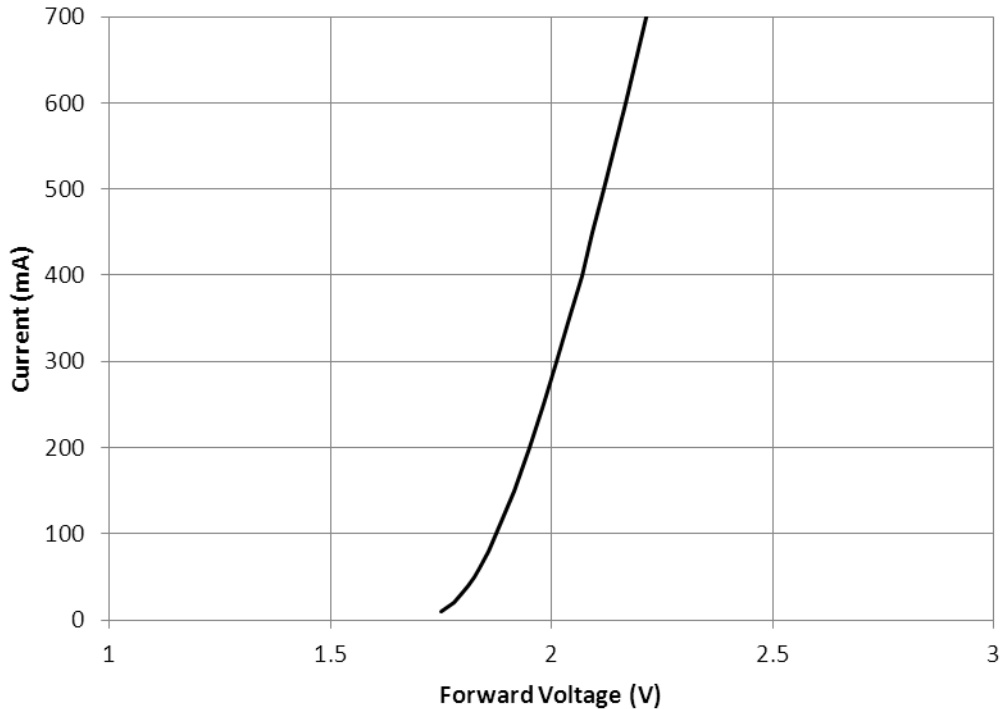

Mechanical Dimensions

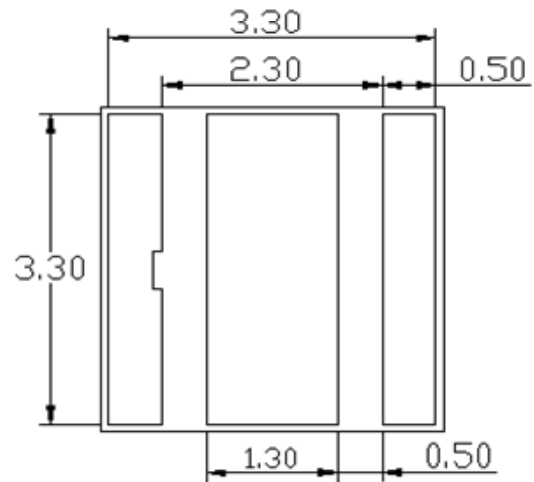
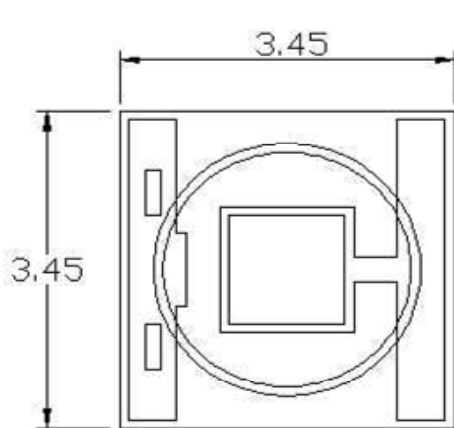
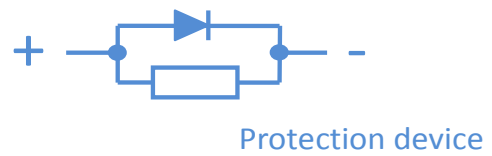
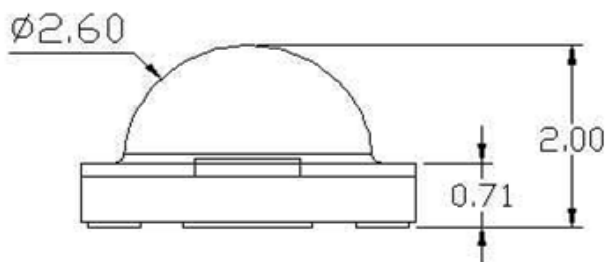
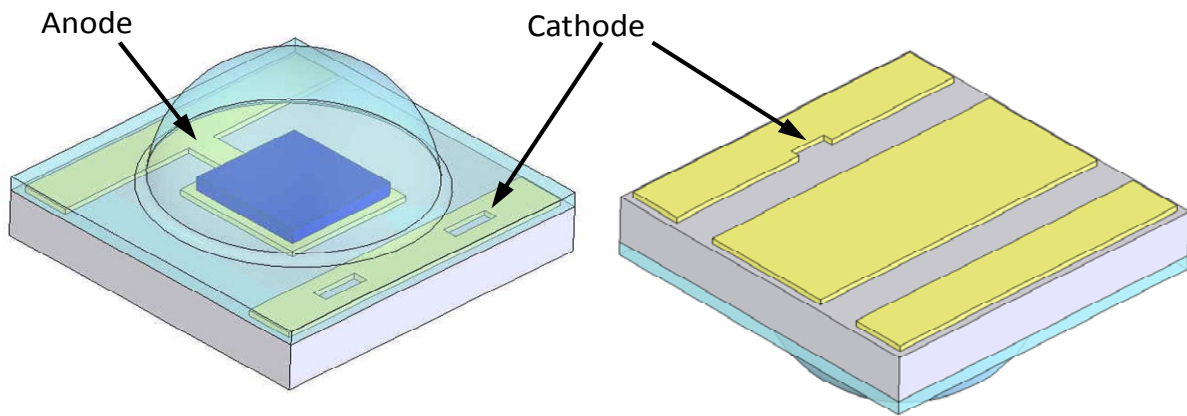

Notes :

1. Drawing is not to scale
2. All dimensions are in millimeter
3. Dimensions are $\pm 0.13\text{mm}$ unless otherwise indicated

Recommended Solder Pad Design

Recommended Soldering Pad Design

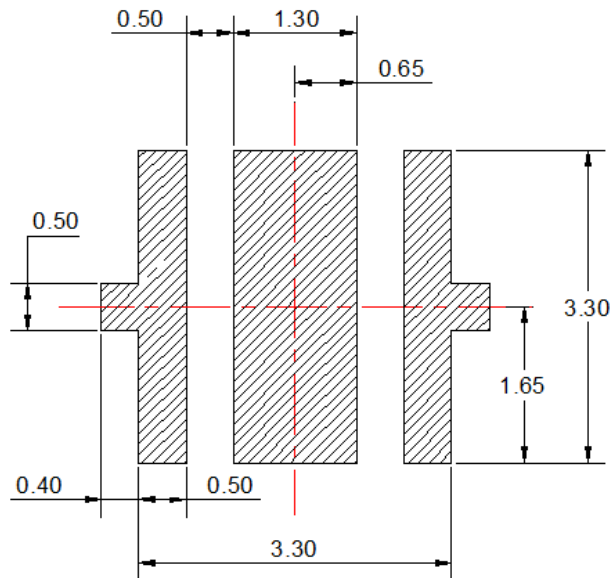

Recommended Stencil Pattern Design (Mark Area is Opening)

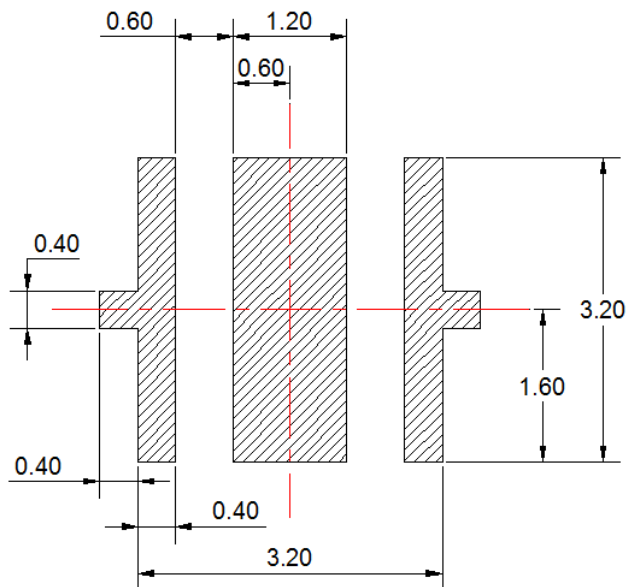

Notes :

1. Drawing is not to scale
2. All dimensions are in millimeter

Packing Information

The carrier tape conform to EIA-481D.

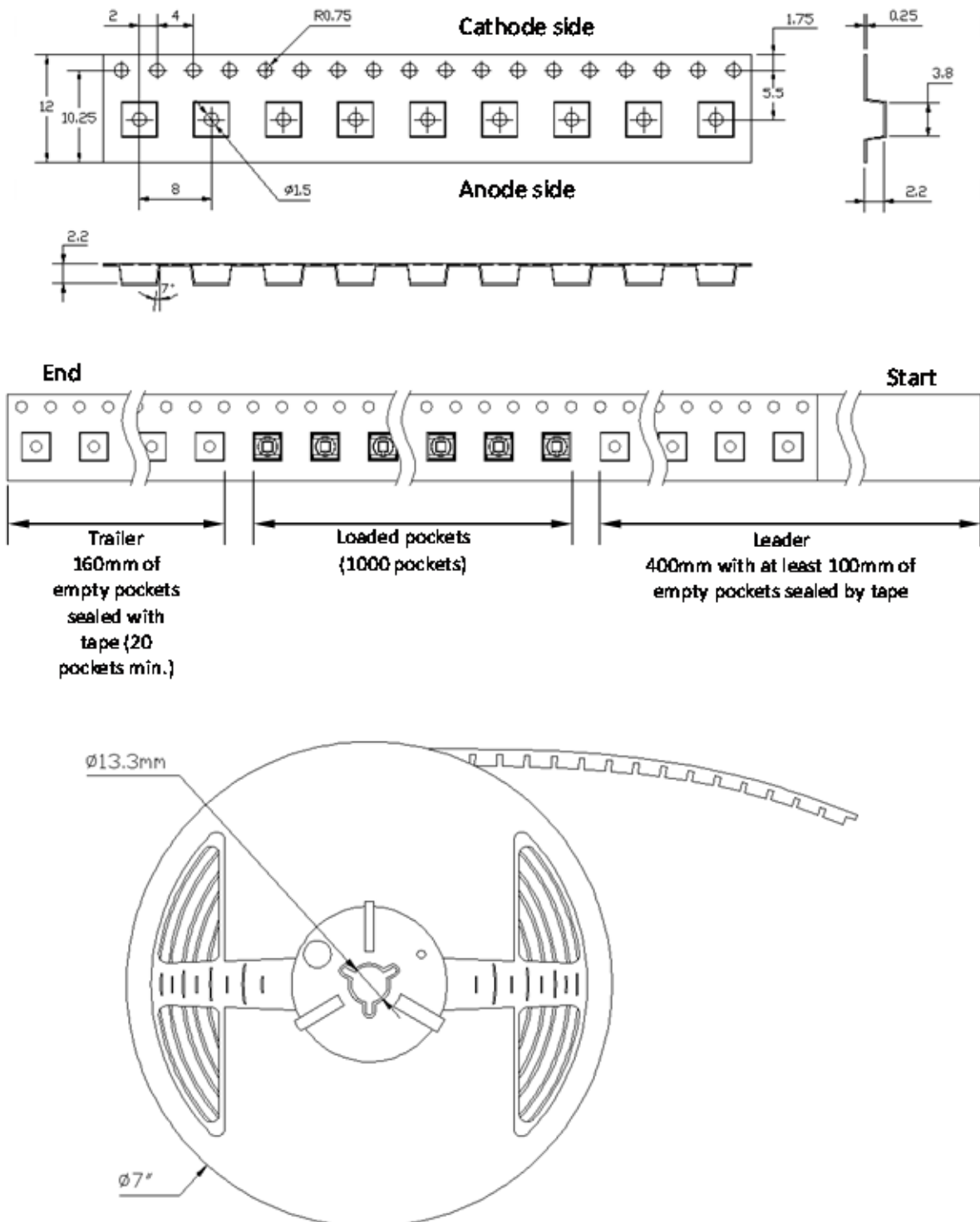

Note:

All dimensions are in millimetre.

Recommended Soldering Profile

The LEDs can be soldered using the parameter listed below. As a general guideline, the users are suggested to follow the recommended soldering profile provided by the manufacturer of the solder paste. Although the recommended soldering conditions are specified in the list, reflow soldering at the lowest possible temperature is advised for the LEDs.

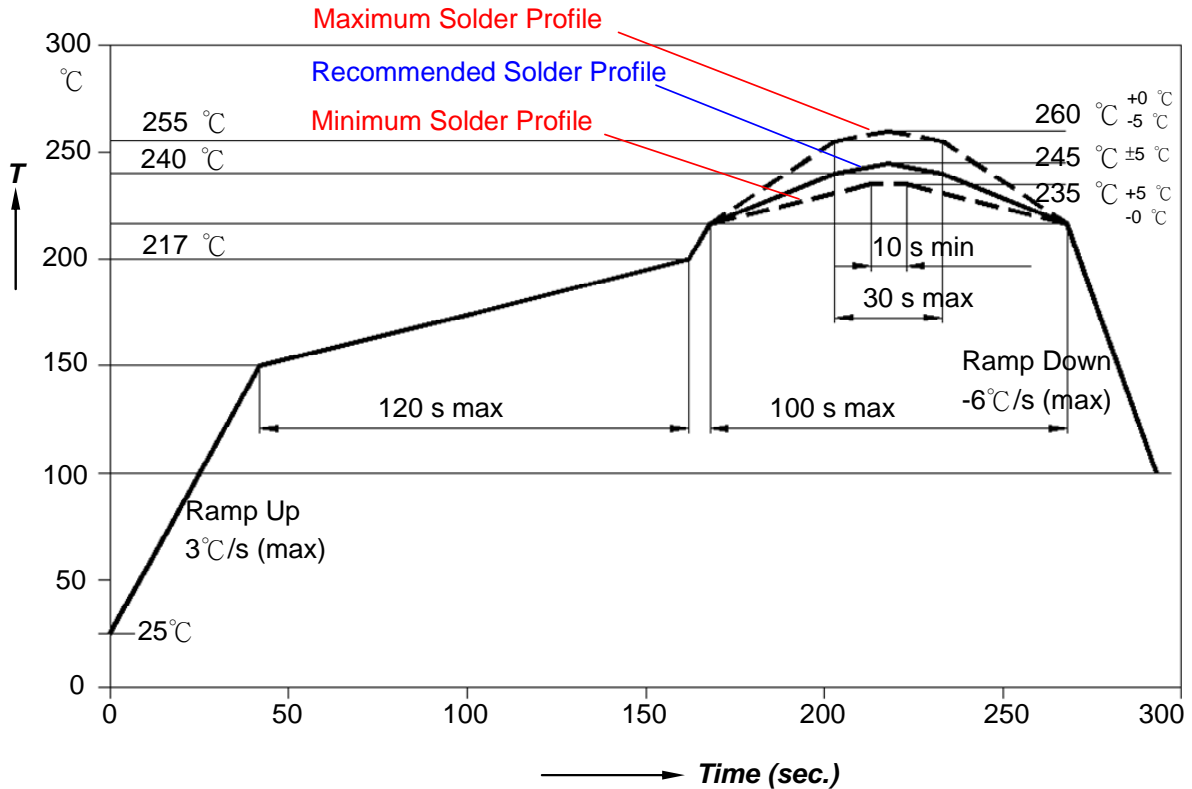

Profile Feature	Sn-Pb Eutectic Assembly	Pb-Free Assembly
Average Ramp-up Rate (T _{smax} to T _p)	3°C/second max.	3°C/second max.
Preheat		
- Temperature Min(T _{smin})	100°C	150°C
- Temperature Max(T _{smax})	150°C	200°C
- Time(t _{smin} to t _{smax})	60-120 seconds	60-180 seconds
Time maintained above:		
- Temperature(T _l)	183°C	217°C
- Time(t _l)	60-150 seconds	60-150 seconds
Peak/classification Temperature(T _p)	215°C	260°C
Time within 5°C of actual Peak Temperature(tp)	10-30 seconds	20-40 seconds
Ramp-Down Rate	6°C/second max.	6°C/second max.
Time 25°C to Peak Temperature	6 minutes max.	8 minutes max.

Notice:

This product is *not for use, sale, or importation into the United States*. Any agreement, documentation, or communication (in any form, through any medium and for any purpose) related to this product is provided subject to the above disclaimer, and no (and seller hereby disclaims any) indemnification is provided for this product against any infringement claim of intellectual property rights in the United States. The limitations above do not apply to products that are purchased and delivered before October 1, 2012.

About Us

SemiLEDs Corporation is a US based manufacturer of ultra-high brightness LED chips with state of the art fabrication facilities in Hsinchu Science Park, Taiwan. SemiLEDs specializes in the development and manufacturing of vertical LED chips in blue (white), green, and UV using a patented copper alloy base. This unique design allows for higher performance and longer lumen maintenance. In December 2008, The World Economic Forum recognized SemiLEDs innovations with the 2009 Technology Pioneer Award. SemiLEDs is fully ISO 9001:2008 and ISO 14001:2004 Certified

SemiLEDs is a publicly traded company on NASDAQ Global Select Market (stock symbol "LEDS"). For investor information, please contact us at investors@semileds.com.

For further company or product information, please visit us at www.semileds.com or please contact sales@semileds.com.



www.semileds.com

ASIA PACIFIC

3F, No. 11, KeJung Rd.

Chu-Nan Site

Hsinchu Science Park

Chu-Nan 350, Miao-Li County

Taiwan, ROC

Tel: +886-37-586788

Fax: +886-37-582688

sales@semileds.com