

Digital transistors (built-in resistors)

DTA124EE / DTA124EUA / DTA124EKA / DTA124ECA / DTA124ESA

●Features

- 1) Built-in bias resistors enable the configuration of an inverter circuit without connecting external input resistors (see the equivalent circuit).
- 2) The bias resistors consist of thin-film resistors with complete isolation to allow positive biasing of the input. They also have the advantage of almost completely eliminating parasitic effects.
- 3) Only the on / off conditions need to be set for operation, making device design easy.

●Structure

PNP digital transistor
(Built-in resistor type)

●Equivalent circuit

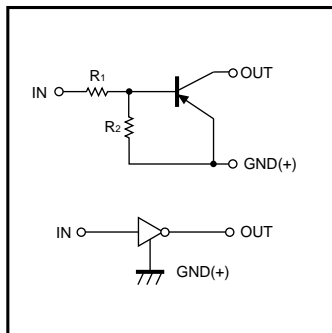

●External dimensions (Units : mm)

DTA124EE		(1) GND (2) IN (3) OUT
ROHM : EMT3	Abbreviated symbol : 15	
DTA124EUA		(1) GND (2) IN (3) OUT
ROHM : UMT3 EIAJ : SC-70	All terminals have same dimensions Abbreviated symbol : 15	
DTA124EKA		(1) GND (2) IN (3) OUT
ROHM : SMT3 EIAJ : SC-59	All terminals have same dimensions Abbreviated symbol : 15	
DTA124ECA		(1) GND (2) IN (3) OUT
ROHM : SST3	All terminals have same dimensions Abbreviated symbol : 15	
DTA124ESA		(1) GND (2) OUT (3) IN
ROHM : SPT EIAJ : SC-72		

DTA124EE / DTC124EUA / DTA124EKA / DTA124ECA / DTA124ESA

Transistor

● Absolute maximum ratings (Ta=25°C)

Parameter	Symbol	Limits(DTA124E□)					Unit
		E	UA	KA	CA	SA	
Supply voltage	V _{CC}	-50					V
Input voltage	V _{IN}	-40~+10					V
Output current	I _o	-30					mA
	I _{C(Max.)}	-100					
Power dissipation	P _d	150		200		300	mW
Junction temperature	T _j	150					°C
Storage temperature	T _{stg}	-55~+150					°C

● Packaging specifications

Part No.	Package	EMT3	UMT3	SMT3	SST3	SPT
	Package type	Taping	Taping	Taping	Taping	Taping
	Code	TL	T106	T146	T116	TP
Basic ordering unit (pieces)		3000	3000	3000	3000	5000
DTA124EE		○	-	-	-	-
DTA124EUA		-	○	-	-	-
DTA124EKA		-	-	○	-	-
DTA124ECA		-	-	-	○	-
DTA124ESA		-	-	-	-	○

● Electrical characteristics (Ta=25°C)

Parameter	Symbol	Min.	Typ.	Max.	Unit	Conditions
Input voltage	V _{I(off)}	-	-	-0.5	V	V _{CC} =-5V, I _o =-100μA
	V _{I(on)}	-3	-	-	V	V _O =-0.2V, I _o =-5mA
Output voltage	V _{O(on)}	-	-0.1	-0.3	V	I _o /I _i =-10mA/-0.5mA
Input current	I _i	-	-	-0.36	mA	V _I =-5V
Output current	I _{O(off)}	-	-	-0.5	μA	V _{CC} =-50V, V _I =0V
DC current gain	G _i	56	-	-	-	V _O =-5V, I _o =-5mA
Input resistance	R ₁	15.4	22	28.6	kΩ	-
Resistance ratio	R ₂ /R ₁	0.8	1	1.2	-	-
Transition frequency	f _T	-	250	-	MHz	V _{CE} =-10V, I _E =5mA, f=100MHz *

* Transition frequency of the device

● Electrical characteristics curves

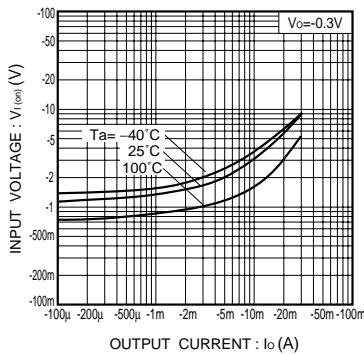

Fig.1 Input voltage vs. output current (ON characteristics)

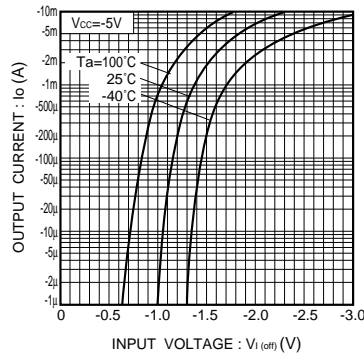

Fig.2 Output current vs. input voltage (OFF characteristics)

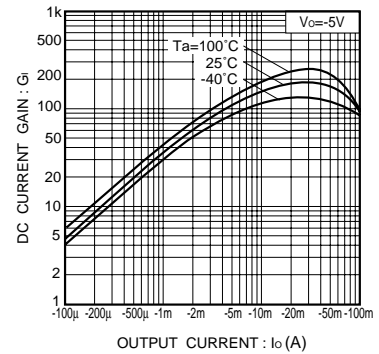

Fig.3 DC current gain vs. output current

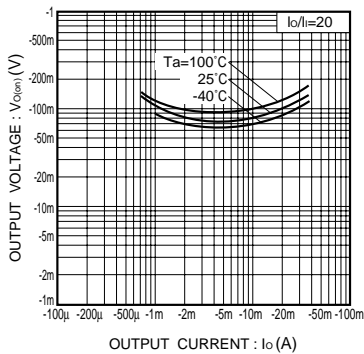

Fig.4 Output voltage vs. output current

Copyright © Each Manufacturing Company.

All Datasheets cannot be modified without permission.

This datasheet has been download from :

www.AllDataSheet.com

100% Free DataSheet Search Site.

Free Download.

No Register.

Fast Search System.

www.AllDataSheet.com