



Powertron - About us:

1. Establishment: Powertron, specialist for Metalfoilresistors, was established in 1991. It was possible for the company to hark back to the profound expertise, knowledge and existing technologies in the region and to develop them.

2. Service: We offer a fully developed engineering department and production facility to buyers, technicians, developers and engineers. With that capability we are able to offer a fast, direct and customer specific work and production. This service is also available for discrete powersemiconductors and powermodules where we have exclusive contracts with selected manufacturers.

3. Location: The Powertron is located in Berlin-Teltow, in the south of Berlin. Here was a centre for passive components, where 5500 specialists were working the electronic production and development.

4. Support: The Powertron is a modern, energetic, unconventionally company, which is working together with customers active and in partnership. We are supporting our customers with advice, technical support and production. We have the needed flexibility to fulfil (nearly) all customer requests. This brings you along - and us also.

5. Product line (overview): Power-Resistors, Precision-Shunt-Resistors, Ultra-Precision-Resistors and Special-Resistors upon customer request are our daily work. This is especially in effect for the demands of tolerances, stability, power and housings of our resistors.

6. Application range (generally): Markets with a high demand for quality, precision and stability for the electronic components. Our customers/partners working in different areas like, railway, automotive, electronic, IT-sector, energy supply and distribution, air and space industries and military applications.

7. Sales: The central office is in Berlin/Teltow. There we are working world wide. Additionally we have sales representatives **in Europe:** Great Britain, Italy, Scandinavia, Netherlands, Belgium and Austria. **And worldwide:** USA, Taiwan and Japan.

Product Summary - Precision and Power Resistors



RESISTORS

Metal-foil technology

Thick-film technology

Standard ranges and customised designs

Environmentally friendly products and manufacturing methods using modern plant technology

Application notes,

Definition of terms and

Test-specifications



Ultra-Precision Resistors

Group I

- Resistors with excellent precision and stability
- Almost temperature-independent

- Planar metal-foil resistors made from NiCr foil on Al_2O_3 or AlN substrates
- Choice of casings

- 1 Ω to 1 M Ω
- Tolerances from 0.005 %
- TCR from 0.2 ppm/K
- Up to 15 W
- Stability class 0.01 %

- IEC approved

Page 5



Precision Shunt Resistors

Group II

- Precision shunts with high stability and high cut-off frequency, achieved by using a special trimming process
 - Very low level of temperature-dependence
- Outstanding dynamic behaviour
 - Two-pole and four-pole technology
- Also suitable for heat sink mounting

- Planar metal-foil resistors made from CuNiMn foil or NiCr foil or sheet on various optimally matched substrates (AlN, Al_2O_3 or Al)
- Choice of casings
- Standard range and customised products

- 50 $\mu\Omega$ to 500 Ω
- Tolerances from 0.01 %
- TCR from 1 ppm/K
- Up to 2500 W / 1000 A
- Stability class 0.01 %

- IEC approved

Page 27



Precision Shunt Networks

Group III

- Resistor networks for precision current measuring with high stability and high cut-off frequency, achieved by using a special trimming process
- Also suitable for heat sink mounting

- Planar metal-foil resistors made from CuNiMn foil on Al substrates
- Choice of casings

- 10 m Ω to 100 Ω across 4 decades
- Tolerances from 0.1 %
- TCR from 15 ppm/K
- Up to 30 W
- Stability class 0.1 %

- IEC approved

Page 69



Power Resistors

Group IV

- Power resistors with high pulse resistance
- High cut-off frequency, achieved by using a special trimming process, also makes these resistors suitable for clocked circuit applications
- Applications include use as starting resistors or braking resistors

- Planar metal-foil resistors and thick-film resistors on Al_2O_3 or AlN substrates
- Choice of casings
- Standard range and customised products

- 1 m Ω to 5 M Ω
- Also available as networks
 - Tolerances from 1 %
 - TCR from 15 ppm/K
- Standard products from to 2.5 kW

- IEC approved

Page 79



Special Resistors

- Customized designs and special developments
- Resistors for direct press-in technology
- Shunts for Energy-Counter
 - TO-220- Housing (also in SMD available)

- TO-5 Housing hermetically sealed
- Resistors for high pulse energy
- Resistors for measurement transformers

- Double resistors for the telecommunication
- Calibration resistors

Page 113

I. ULTRA-PRECISION-RESISTORS

Ultra-Precision

Type	Resistance Range	Power max.	Temperature Coefficient	Tolerance	Stability	Page
UPW 2-0808	1R...150k	0.25 Watt	±4.0ppm/K	0.01%	0.01%	7
USR UNR 2-0710	1R0 ... 150k	0,6 Watt	ab ± 1ppm/K	0,005%	0,01%	9
USR 2-0710-300K	150k...300k	0.6 Watt	typ. ±3.0ppm/K	0.005%	0.01%	11
USH 2-0710	100R...100k	0.6 Watt	±0.2ppm/K	0.005%	0.005%	13
USR 2-0808 USR 2-0808-300K USR 2-1510 USR 2-2110 USR 2-3010	0R5...1M	2.0 Watt	typ. ±3.0ppm/K	0.005%	0.01%	15
USR UNR 2-1410	1R0 ... 300k0	0.8 Watt	± 1ppm/K	0.01%	0.01%	19
USN 2-0808 UPN 2-0808	100R...20k	0.2 Watt	typ. ±3.0ppm/K	0.005%	0.001%	21
USN 2-1410	1R0 ... 150k0	0,4 Watt	ab ± 1ppm/K	0,05%	0,01%	23
USR UNR 2-T220 USR UNR 2-T220B USR UNR 2-T221 USS UNS 2-T220	0R5 ... 150k0	15 Watt	± 3ppm/K	0.01%	0.01%	25

UPW 2-0808



- Highest stability
- Low electrical noise
- Customized resistance values
- Tolerances from 0.005%

SPECIFICATIONS

ELECTRICAL

UPW 2-0808

Resistance Range	:	1R0 ... 150k
Power Rating (70°C)	:	0.25 W (<100k) 0.20 W (>100k)
Tolerances	:	
from 1R	:	0.5%, 1%
from 5R	:	0.05%, 0.1%, 0.25%, 0.5%, 1%
from 25R	:	0.01%, 0.02%, 0.05%, 0.1%, 0.25%, 0.5%, 1%
Stability	:	0,01%
Temperature Coefficient	:	max. ±8 ppm/K (-55..125)°C max. ±4 ppm/K (0..60)°C
Insolation Resistance	:	> 10 GOhm
Thermal EMF	:	< 0.1 µV/K

ENVIRONMENTAL

Operating Temperature Range : -55°C...155°C

MECHANICAL

Resistor Material	:	NiCr-Foil
Substrate	:	Al ₂ O ₃
Housing	:	PBTP / Epoxy
Connector Material	:	Cu tinned 2-pin

TEMPERATURE COEFFICIENT

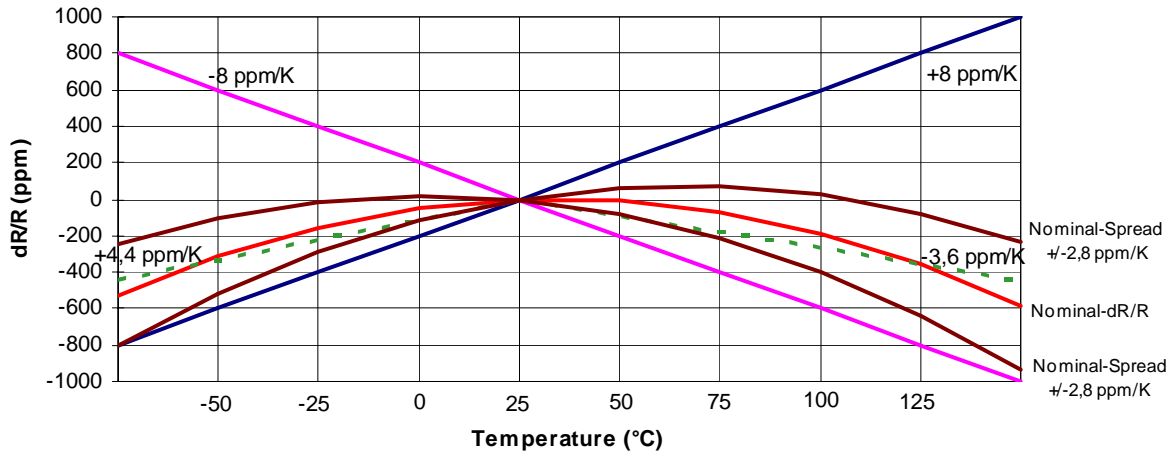

DERATING CURVE

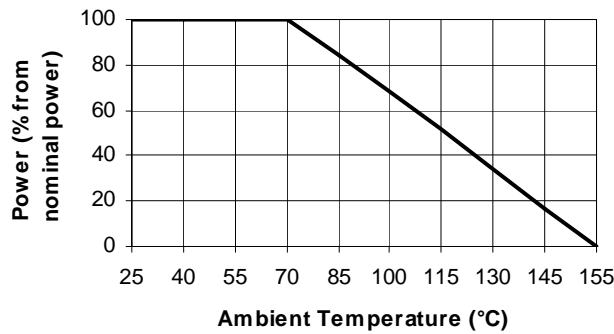

DIMENSIONS

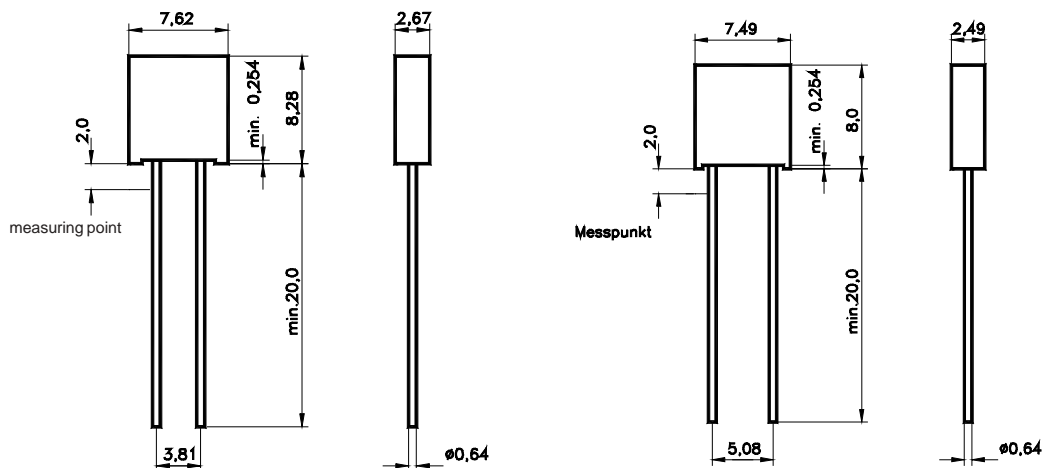

Grid 3.81mm = D
 Grid 5.08mm = J
 Dimensions in mm

HOW TO ORDER

UPW 2-0808 5K10 J 0.01% TK4 (RM508)



- Highest Stability
- Near Temperature Independence
- Lowest Tolerances
- Low Capacitance and Inductance
- Customized Resistance Values

SPECIFICATIONS

ELECTRICAL

	USR 2-0710	UNR 2-0710 note ¹⁾
Resistance Range	: 1R0...150k	: 1R0 ... 5k
Power Rating	: 0.4 W (70°C) <5k (0.6 W upon request possible)	: 0.6 W (70°C) >5k
Tolerance	:	:
from 1R0	: 0.1%, 0.25%, 0.5%, 1%	
from 10R	: 0.05%, 0.1%, 0.25%, 0.5%, 1%	
from 50R	: 0.01%, 0.02%, 0.05%, 0.1%, 0.25%, 0.5%, 1%	
from 100R	: 0.005%, 0.01%, 0.02%, 0.05%, 0.1%, 0.25%, 0.5%, 1%	
Stability	: 0.01%	
Temperature Coefficient	: max. ±5 ppm/K (-55..155)°C typ. ±3 ppm/K (-55..125)°C upon request ±1 ppm/K (0..60)°C and ±1 ppm/K (-55 ... 125)°C	
Insolation Resistance	: > 10 GOhm	
Thermal EMF	: < 1 µV/K	

ENVIRONMENTAL

Operating Temperature Range : -55°C...155°C

MECHANICAL

Resistor Material	: NiCr-Foil	
Substrate	: Al ₂ O ₃	AIN
Housing	: PBTP / Epoxy	
Connector Material	: Cu tinned 2-pin	

note¹⁾: Specially designed for applications with fast changing electrical load.

TEMPERATURE COEFFICIENT

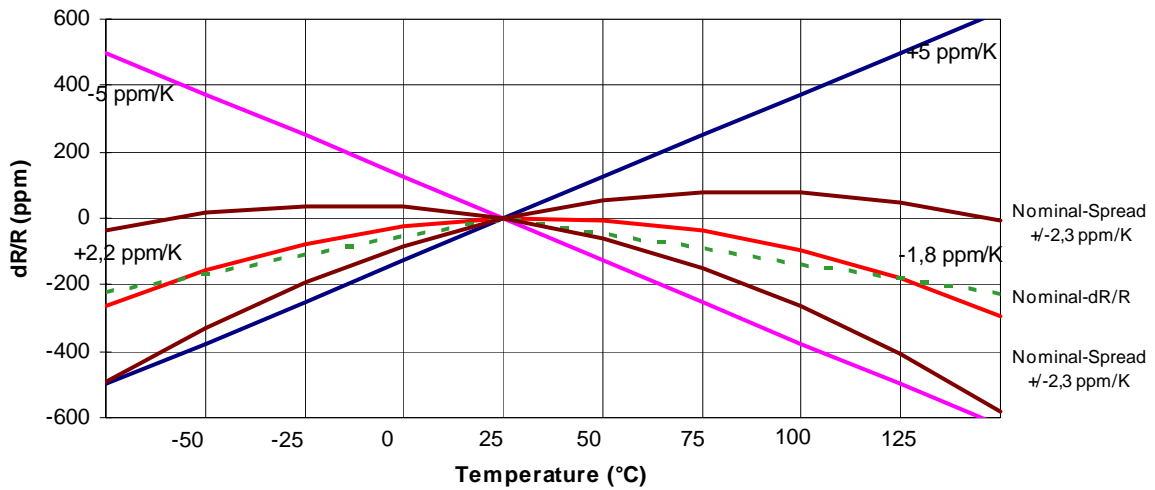

DERATING CURVE

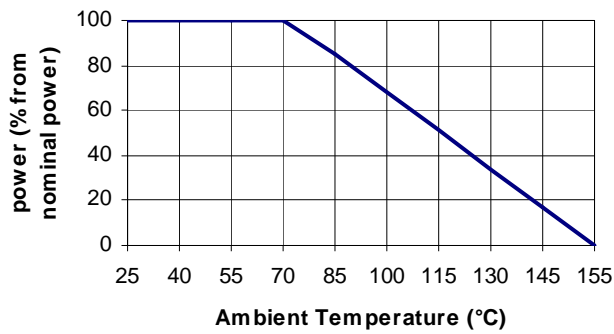

DIMENSIONS

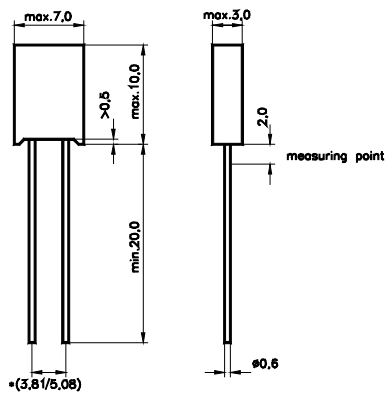

Grid 3.81mm = D
 Grid 5.08mm = J
 Dimensions in mm

HOW TO ORDER

USR 2-0710 5K43 D 0.01% TK3

UNR 2-0710 3R7 J 0.5% TK1

USR 2-0710-300K



- Highest stability
- Temperature Coefficient 1 ppm/K
- Low electrical noise and low inductance
- Customized Resistance Values
- Tolerances from 0.005%

SPECEIFICATIONS

ELECTRICAL

USR 2-0710-300K

Resistance Range	:	150k ... 300k
Power Rating	:	0.6 W (70°C)
Tolerances	:	0.005%, 0.01%, 0.02%, 0.05%, 0.1%, 0.25%, 0.5%, 1%
Stability	:	0.01%
Temperature Coefficient	:	max. ± 5 ppm/K (-55..155)°C typ. ± 3 ppm/K (-55..125)°C upon request ± 1 ppm/K (0..60)°C and ± 1 ppm/K (-55 ... 125)°C
insolation Resistance	:	> 10 GOhm
Thermal EMF	:	< 1 μ V/K

ENVIRONMENTAL

Operating Temperature Range	:	-55°C...155°C
------------------------------------	---	---------------

MECHANISCH

Resistor Material	:	NiCr-Foil
Substrate	:	Al ₂ O ₃
Housing	:	PBTP / Epoxy
Connector Material	:	Cu tinned 2-pin

TEMPERATURE COEFFICIENT

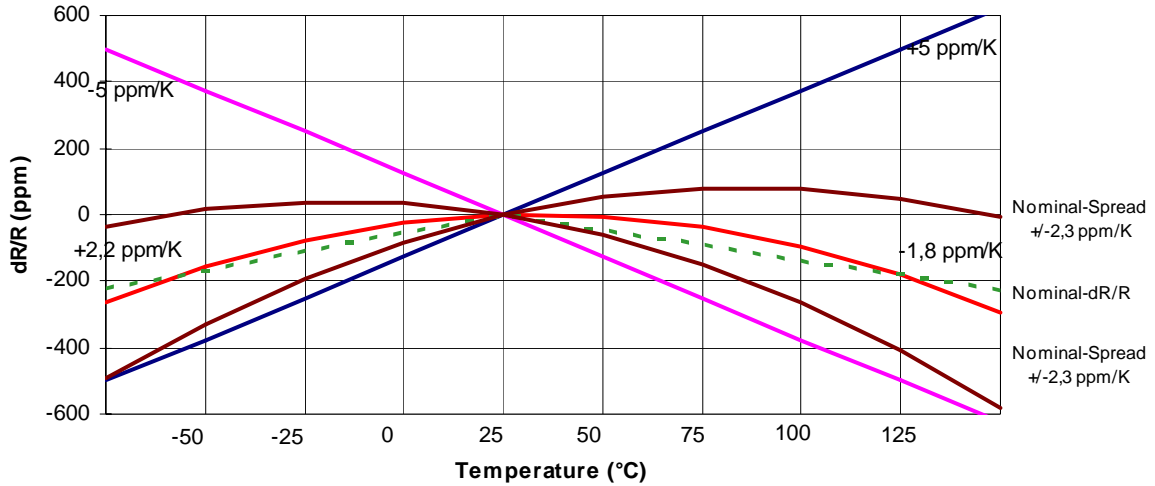

DERATING CURVE

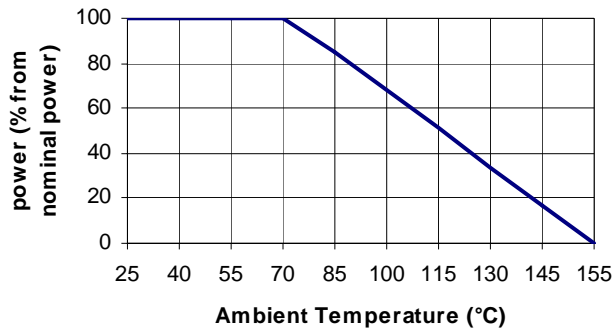

DIMENSIONS

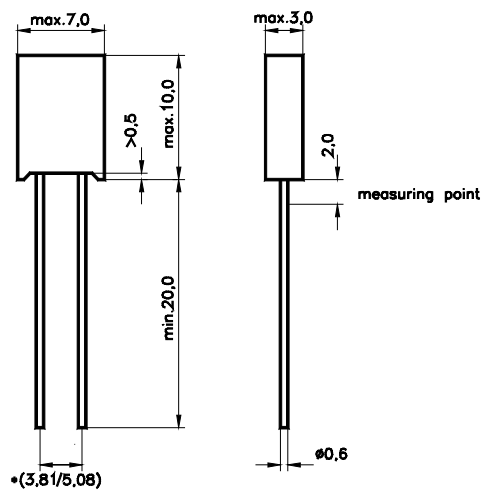

Grid 3.81 mm = D
 Grid 5.08 mm = J
 Dimensions in mm

HOW TO ORDER

USR 2-0710-300K 245K10 D 0.01% TK3

USH 2-0710



- **Highest Stability**
- **Temperature Coefficient 0.2 ppm/K**
- **Low electrical noise and low inductance**
- **Customized resistance values**
- **Tolerances from 0.005%**

SPECIFICATIONS

ELECTRICAL

USH 2-0710

Resistance Range	:	100R ... 100k
Power Rating	:	0.6 W (70°C)
Tolerances	:	0.005%, 0.01%, 0.02%, 0.05%, 0.1%, 0.25%, 0.5%, 1%
Stability	:	0.005% (2.000h, 0.1W/+70°C)
Temperature Coefficient	:	nom. 0.1 ppm/K (0...60)°C nom. 0.2 ppm/K (-55...125)°C max. 0.8 ppm/K (-55...125)°C
Insolation Resistance	:	> 10 GOhm
Thermal EMF	:	< 0.1 μ V/K

ENVIRONMENTAL

Operating Temperature Range	:	-55°C...155°C
------------------------------------	---	---------------

MECHANICAL

Resistor Material	:	NiCr-Foil
Substrate	:	Al ₂ O ₃
Housing	:	PBTP / Epoxy
Connector Material	:	Cu tinned 2-pin

TEMPERATURE COEFFICIENT

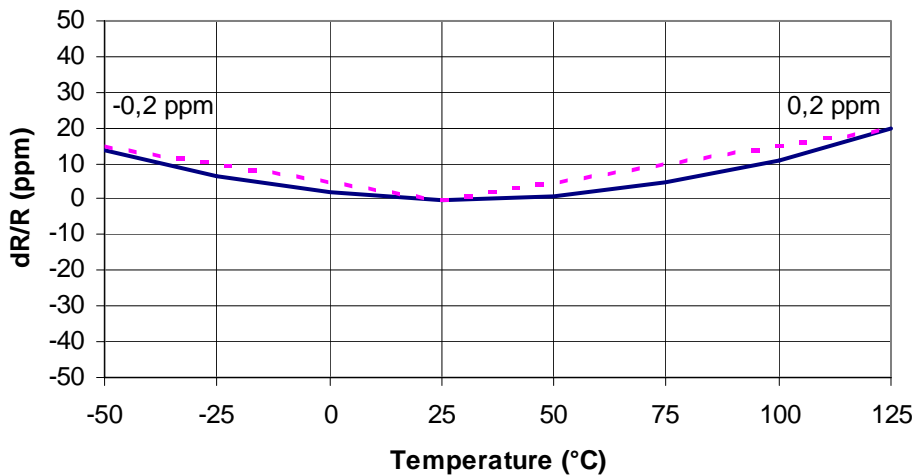

DERATING CURVE

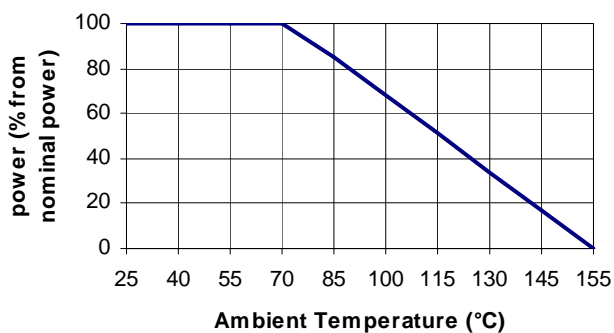

DIMENSIONS

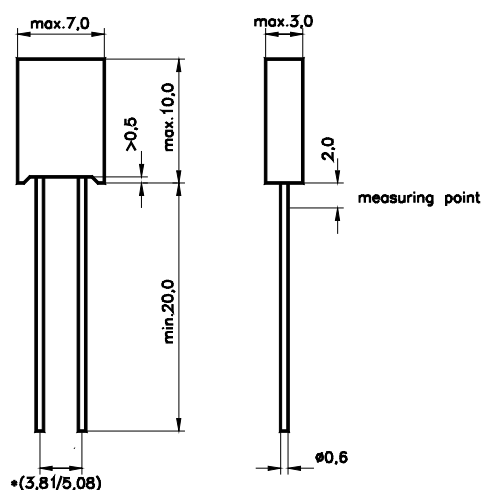

Grid 3.81 mm = D
 Grid 5.08 mm = J
 Dimension in mm

HOW TO ORDER

USH 2-0710-50K0 D 0.005%

USR 2-0808, 0808-300K, 1510, 2110, 3010

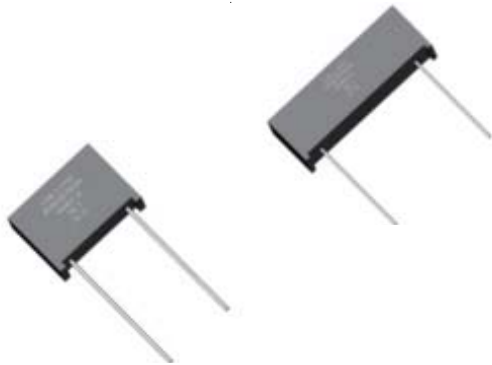

- highest Stability
- Temperature Coefficient 1ppm/K
- Low electrical noise and low inductance
- Customized resistance values
- Tolerances from 0.005%

SPECIFICATIONS

ELECTRICAL	USR 2-0808	0808-300K	1510	2110	3010
Resistance Range	: 1R...150k	150K..300k	1R...500k	1R...750k	0R5...1M
Power Rating (70°C)	: 0.6W (<100K) 0.4W (>100K)	0.6W	1.0W (<200K) 0.6W (>200K)	1.5W (<300K) 0.8W (>300K)	2.0W (<400K) 1.0W (>400K)
Tolerances	:				
from 1R	:	: 0.5%, 1%			
from 5R	:	: 0.05%, 0.1%, 0.25%, 0.5%, 1%			
from 25R	:	: 0.01%, 0.02%, 0.05%, 0.1%, 0.25%, 0.5%, 1%			
from 100R	:	: 0.005%, 0.01%, 0.02%, 0.05%, 0.1%, 0.25%, 0.5%, 1%			
Stability	:	: 0.01%			
Temperature Coefficient	:	: max. ±5 ppm/K (-55..155)°C typ. ±3 ppm/K (-55..125)°C upon request ±1 ppm/K (0 ... 60)°C and ±1 ppm/K (-55 ... 125)°C			
Insolation Resistance	:	: > 10 GOhm			
Thermal EMF	:	: < 0.1 µV/K			

ENVIRONMENTAL

Operating Temperature Range : -55°C...155°C

MECHANICAL

Resistor Material	:	NiCr-Foil
Substrate	:	Al ₂ O ₃
Housing	:	PBTP / Epoxy
Connector Material	:	Cu tinned 2-pin

TEMPERATURE COEFFICIENT

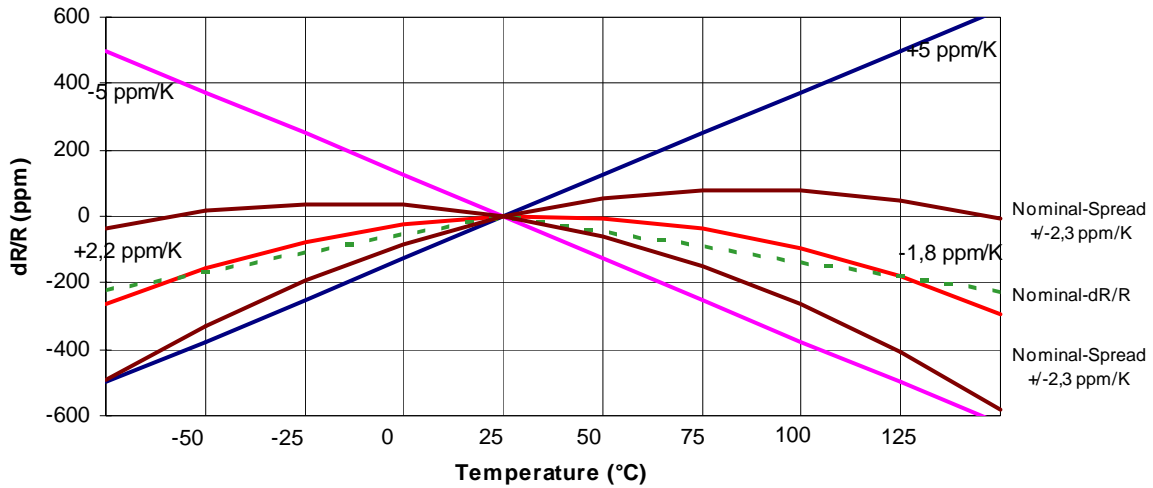

DERATING CURVE

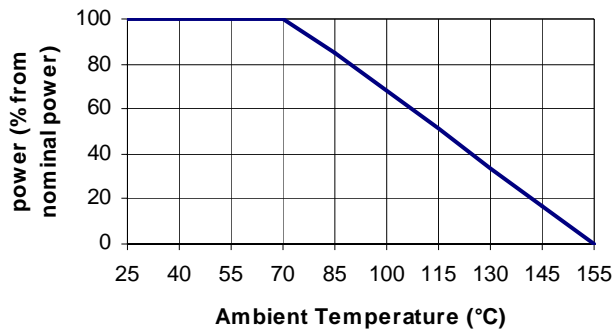

DIMENSIONS

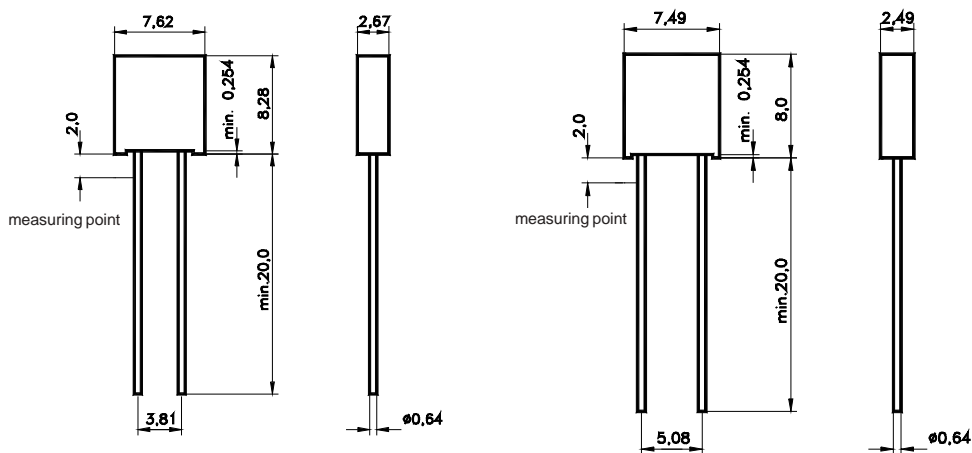

USR 2-0808 lead spacing 3.81 (D)

USR 2-0808 lead spacing 5.08 (J)

DIMENSIONS

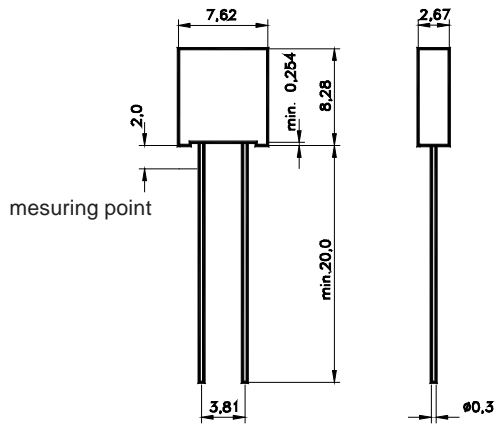

USR 2-0808-300K lead spacing 3.81 (D)

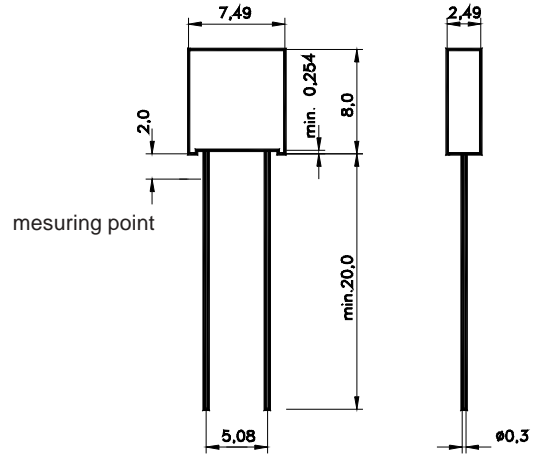

USR 2-0808-300K lead spacing 5.08 (J)

USR 2-1510

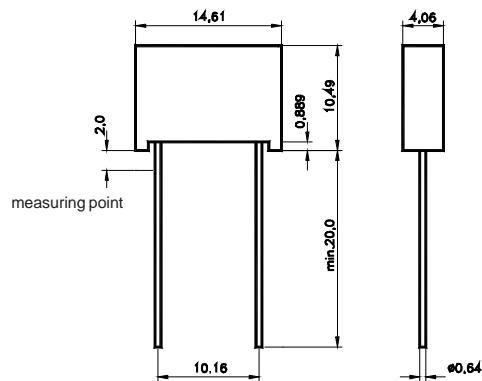

DIMENSIONS

USR 2-2110

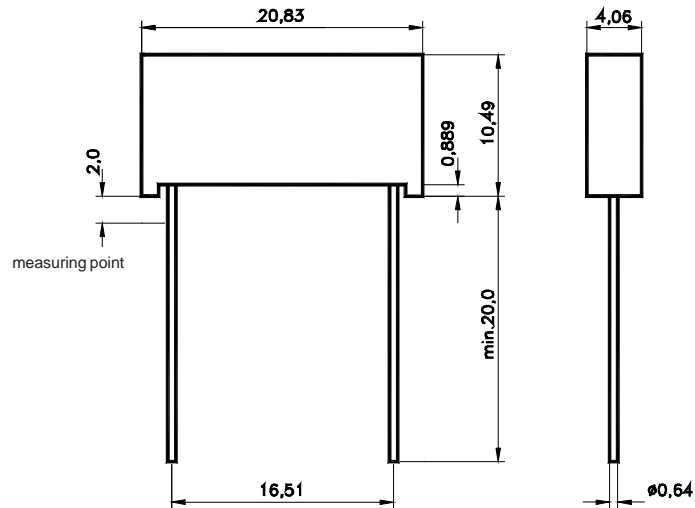

USR 2-3010

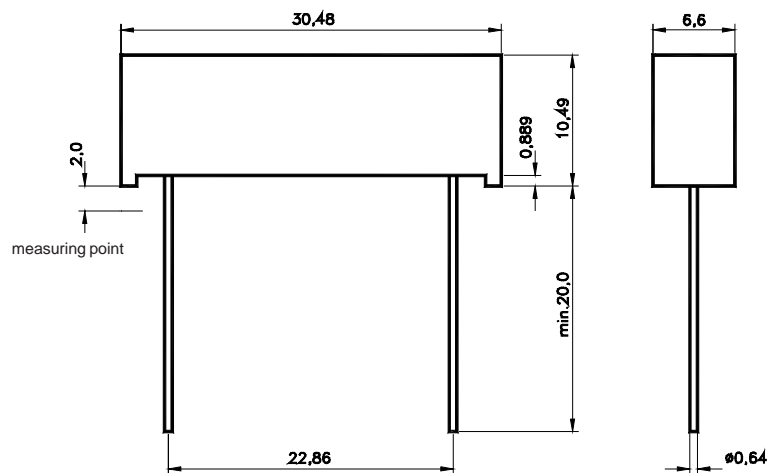

Angaben in mm

HOW TO ORDER

USR 2-0808 5K43 D 0,01% TK3 (RM381)

USR 2-0808 230K0 J 0,01% TK3 (RM508)

USR 2-3010 3R7 0,5% TK1

USR UNR 2-1410



- **Highest Stability**
- **Near Temperature Independency**
- **Lowest Tolerances (0.01%)**
- **Low Capacitance and Inductance**
- **Customized Resistance Values**

SPECIFICATIONS ELECTRICAL

	USR 2-1410	UNR 2-1410 note ¹⁾
Resistance Range	: 1R0...300k	1R0 ... 10k
Power Rating	: 0.8 W (70°C)	
Tolerance	:	
from 1R0	: 0.1%, 0.25%, 0.5%, 1%	
from 10R	: 0.05%, 0.1%, 0.25%, 0.5%, 1%	
from 50R	: 0.01%, 0.02%, 0.05%, 0.1%, 0.25%, 0.5%, 1%	
Stability	: 0.01%	
Temperature Coefficient	: max. ±5 ppm/K (-55..155)°C typ. ±3 ppm/K (-55..125)°C upon request ±1 ppm/K (0..60)°C	
Insulation Resistance	: > 10 GOhm	
Thermal EMF	: < 1 µV/K	

ENVIRONMENTAL

Operating Temperature Range : -55°C...155°C

MECHANICAL

Resistor Material	: NiCr-Foil	
Substrate	: Al ₂ O ₃	AlN
Housing	: PBTP / Epoxy	
Connector Material	: Cu tinned 2-pin	

note¹⁾: Specially designed for applications with fast changing electrical load.

TEMPERATURE COEFFICIENT

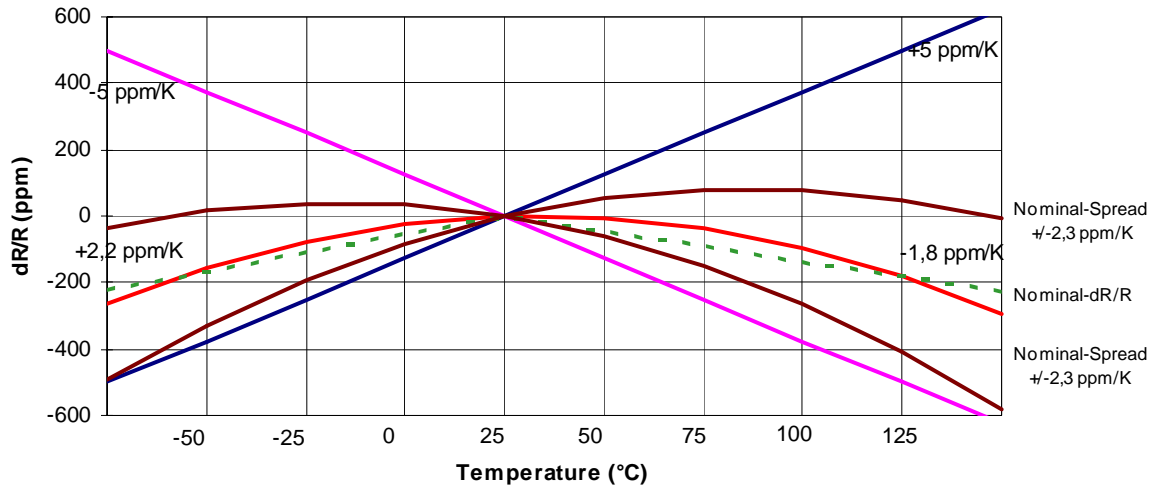

DERATING CURVE

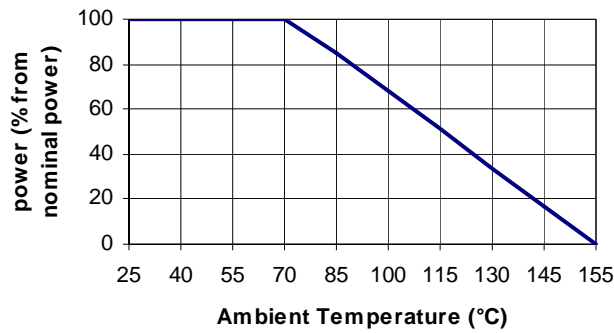

DIMENSIONS

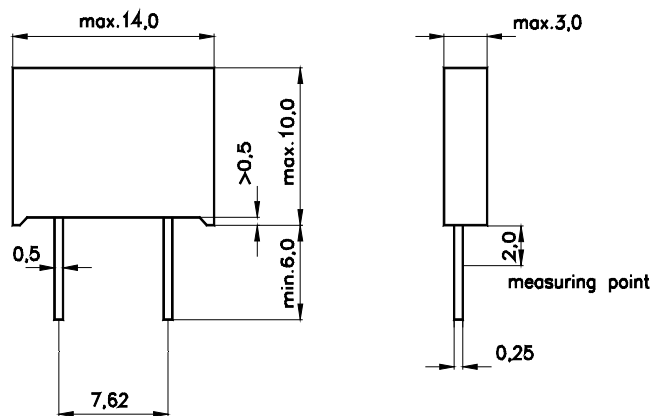

Lead X (Standardlead)
from 100R0 with wire bonding d=0.6mm (contact D)

Dimensions in mm

HOW TO ORDER

USR 2-1410 7K0 D 0.01% TK1

UNR 2-1410 2R5 X 0.5% TK3

USN 2-0808 UPN 2-0808



- Double Resistor
- Highest Stability
- Temperature Coefficient 1ppm/K
- Tolerances from 0.05%
Difference between resistors from 0.01%
- Low electrical noise and low inductance
- Customized resistance values
- TC-Tracking \leq 1ppm/K

SPECIFICATIONS

ELECTRICAL

	USN 2-0808	UPN 2-0808
Resistance Range	: 100R ... 20K	
Variations	: Double-resistor with middel-pin (R1-R2)	
Power Rating	: 0.2 W (70°C) (R1 + R2)	
Tolerances	:	
Absolut	: from 0.005%	from 0.02%
Ratio	: from 0.005%	from 0.02%
Stability (Ratio)	: 0.001%	0.001%
Temperature Coefficient	:	
Absolut	: typ. \pm 3 ppm/K	typ. \pm 5 ppm/K
Tracking	: < 1.0 ppm/K	< 2.0 ppm/K
upon request	: < 0.5 ppm/K	< 1.5 ppm/K
Insolation Resistance	: > 10 GOhm	
Thermal EMF	: < 0.1 μ V/K	

ENVIRONMENTAL

Operating Temperature Range : -55°C...155°C

MECHANICAL

Resistor Material	: NiCr-Foil
Substrate	: Al ₂ O ₃
Housing	: Capsule / Epoxy
Connector Material	: Cu tinned 3-pin

DERATING CURVE

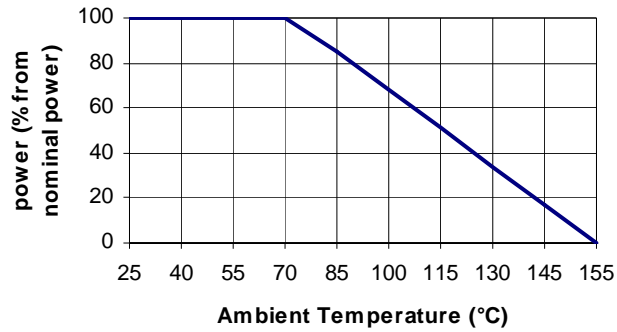

DIMENSIONS

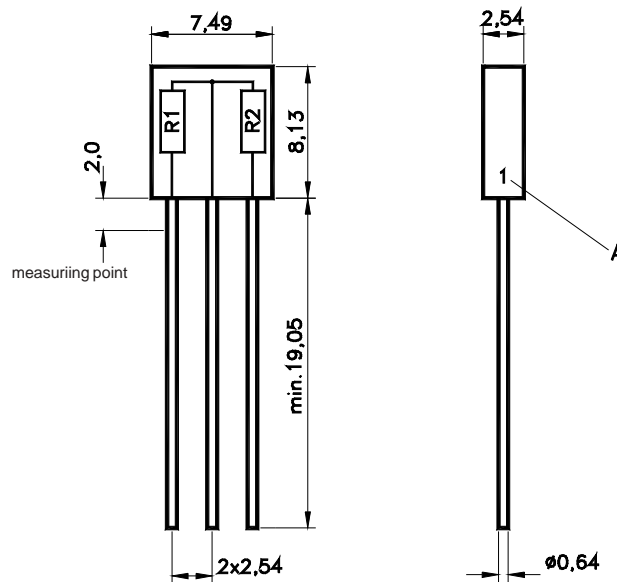

A = Marking of the position of the low ohmic resistor

Dimensions in mm

HOW TO ORDER
USN 2-0808 2K-4K 0.01%

UPN 2-0808 500R-15K 0.1%



- **Highest Stability**
- **Near Temperature Independency**
- **Lowest tolerances**
- **Low Capacitance and Inductance**
- **Customized Resistance Values**

SPECIFICATIONS

ELECTRICAL

Resistance Range	:	1R...150k
Possible Variations	:	Double-resistor with middle-pin (R1-R2) or two single resistors
Power Rating	:	0.4 W (70°C) per resistor
Tolerance	:	0.05%, 0.1%, 0.25%, 0.5%, 1%
Stability	:	0.01%
Temperature Coefficient	:	max. ± 5 ppm/K (-55...155)°C typ. ± 3 ppm/K (-55...125)°C upon request ± 1 ppm/K (0...60)°C TK-Tracking 1 ppm/K (< 1ppm/K upon request)
Insulation Resistance	:	> 10 GOhm
Thermal EMF	:	< 1 μ V/K

ENVIRONMENTAL

Operating Temperature Range	:	-55°C...155°C
------------------------------------	---	---------------

MECHANICAL

Resistor Material	:	NiCr-Foil
Substrate	:	Al ₂ O ₃
Housing	:	Capsule / Epoxy
Connector Material	:	Cu tinned 3 or 4 pin

TEMPERATURE COEFFICIENT

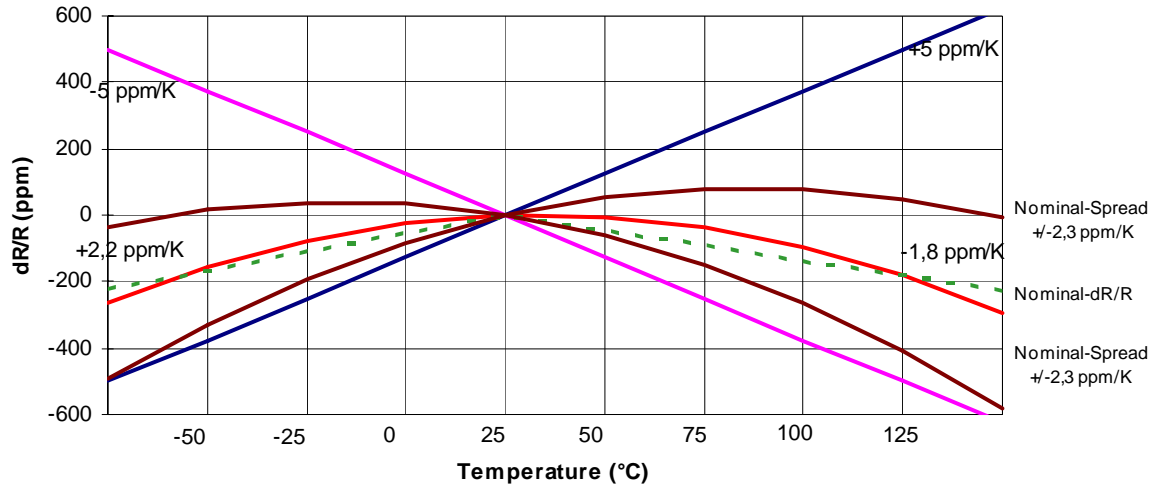

DERATING CURVE

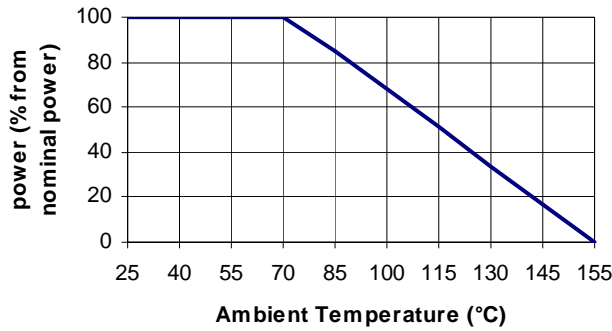

DIMENSIONS

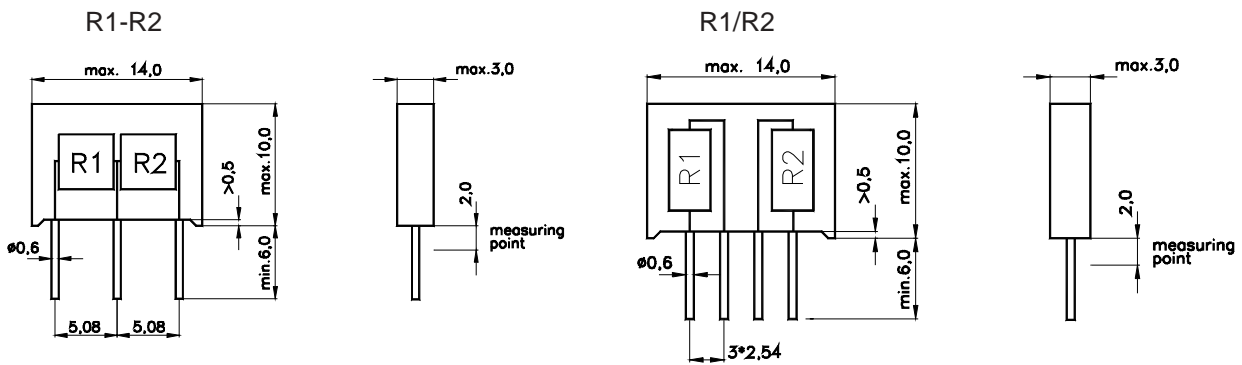

wire bonding $d=0.6\text{mm}$ (contact D)

Dimensions in mm

HOW TO ORDER

USN 2-1410 1K0-9K0 D 0.1% TK5 Tracking 1ppm

USR UNR 2-T220 2-T220B 2-T221
USS UNS 2-T220



- **Highest Stability**
- **Near Temperature Independency**
- **Lowest Tolerances**
- **Low Capacitance and Inductance**
- **High Power Rating (15 Watt)**

SPECIFICATIONS

ELECTRICAL

	USR / USS	UNR / UNS
Resistor Range	: 0R5...150k	note ¹⁾ 0R5...5K
Power Rating	: 1.5 W (70°C) without heatsink (R>50R: 1W) 10 W* (R>50R: 6W) * with heatsink	15 W* (R>50R: 10W)
Thermal Resistance Rthj-c	: 10.8 K/W (R>50R: 18.8 K/W)	6.8 K/W (R>50R: 10.8 K/W)
Tolerances	:	
from 0R5	: 0.1%, 0.25%, 0.5%, 1%	
from 10R	: 0.05%, 0.1%, 0.25%, 0.5%, 1%	
from 50R	: 0.01%, 0.02%, 0.05%, 0.1%, 0.25%, 0.5%, 1%	
Stability	: 0.01%	
Temperature Coefficient	: max. ±5 ppm/K (-55...155)°C typ. ±3 ppm/K (-55...125)°C	
Insolation Resistance	: 1 kVDC	
Thermal EMF	: < 1 µV/K	

ENVIRONMENTAL

Operating Temperature Range : -55°C...155°C

MECHANICAL

Resistor Material	: NiCr-Foil	
Substrate	: Al ₂ O ₃	AlN
Housing	: Epoxy + Cu heatsink nickelt	
Connector Material	: Cu tinned, 2-pin	
Max. torque backplate	: 1.0 Nm	

note¹⁾: Specially designed for applications with fast changing electrical load.

TEMPERATURE COEFFICIENT

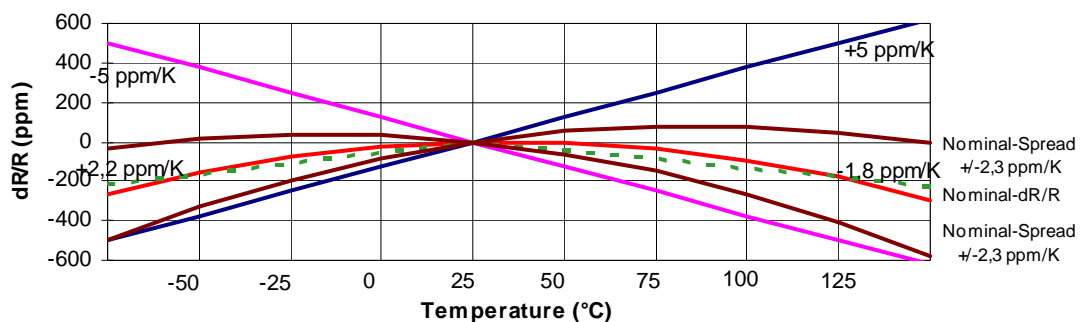

USR UNR 2-T220 2-T220B 2-T221
USS UNS 2-T220



DERATING CURVE

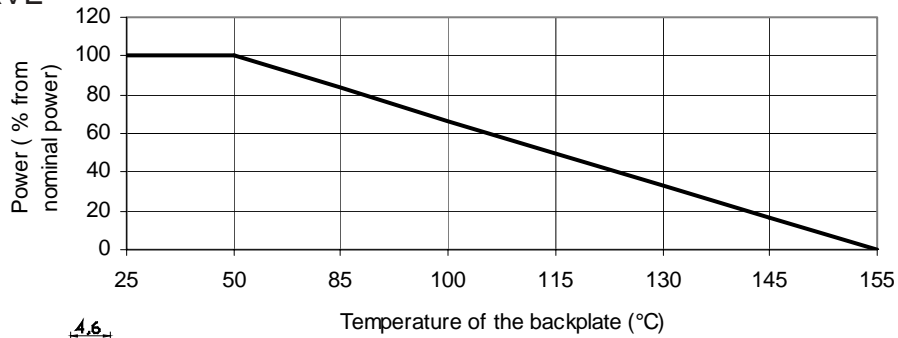

DIMENSIONS

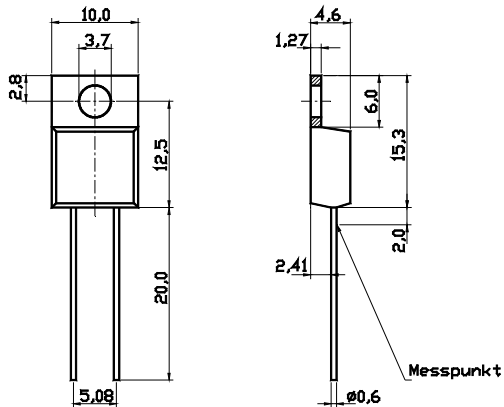

USR 2-T220
 UNR 2-T220

Housing for special demand and small quantities

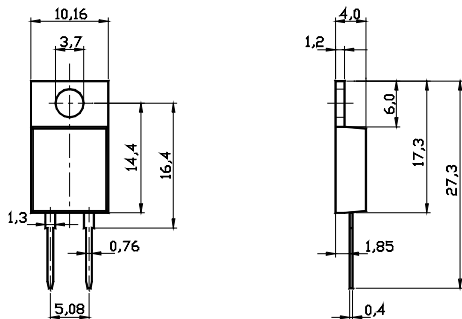

USR 2-T220B / UNR 2-T220B

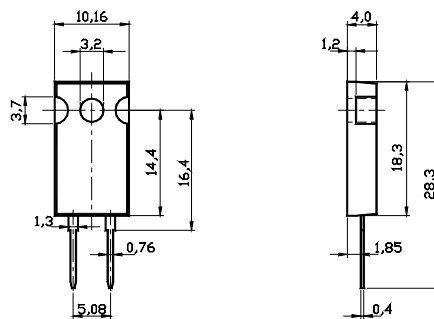

USR 2-T221 / UNR 2-T221

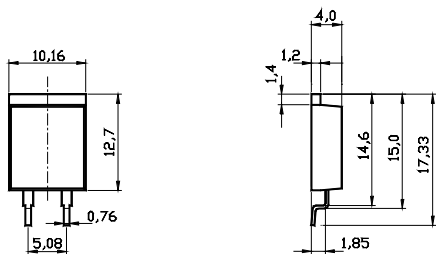

USS 2-T220 / UNS 2-T220

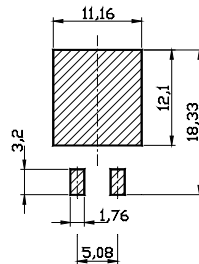

Dimensions in mm

HOW TO ORDER

USR2-T220 15R4 D 0.1% TK5

UNR2-T220 5K0 D 0.1% TK3

II. PRECISION-SHUNT-RESISTORS

Precision-Shunt

Type	Resistance Range	Power max.	Temperature Coefficient	Tolerance	Stability	Page
USR UNR 4-1410	0R1 ... 100R	0.8 Watt	± 1ppm/K	0.01%	0.01%	29
USR 4-1414	0R5 ... 100R	25 Watt	± 1ppm/K	0.01%	0.01%	31
USR UNR 4-T220 USR UNR 4-T220B USR UNR 4-T221 USS UNS 4-T220	0R2 ... 80R	15 Watt	± 1ppm/K	0.01%	0.01%	33
USR UNR 4-3425, 4-3825, 4-3825H	0R05 ... 500R	50 Watt	± 1ppm/K	0.01%	0.01%	35
USR UNR 4-4020	0R05 ... 500R	50 Watt	± 1ppm/K	0.01%	0.01%	37
FPR 2-1617, 2-1623, 2-2614	0R01 ... 100R	2 Watt	± 15ppm/K	0.1%	0.1%	39
FPR 4-2321, FPR 4-3316	0R0005...100R	2 Watt	± 15ppm/K	0.1%	0.1%	41
FPR 2-T218	0R002 ... 50R	30 Watt	± 15ppm/K	0.1%	0.1%	43
FPR 2-T220, 2-T220, 4-T221 FPS 2-T220, 4-T220	0R002 ... 50R	15 Watt	± 15ppm/K	0.1%	0.1%	45
FPR 4-1414	0R01 ... 1R	25 Watt	± 15ppm/K	0.1%	0.1%	49
FHR 2-3025, 2-3818, 4-4618, 4-3825/3825H	0R001 ... 100R	50 Watt	± 15ppm/K	0.1%	0.1%	51
FHR FNR 2-T238, 4-T238	0R001 ... 100R	80Watt	± 15ppm/K	0.5%	0.1%	55
FPR FNR 2-T227, 4-T227	0R001 ... 100R	80 Watt	ab ± 15ppm/K	0,5%	0,1%	59
FHR 4-8065, 80110, 80216, 80320, 80370	0R001 ... 500R	2500 Watt	± 15ppm/K	0.1%	0.1%	63
FHR 2/4 -6520...120120	50µR ... 1000µR	50 Watt	± 15ppm/K	1.0%	0.1%	65

USR UNR 4-1410

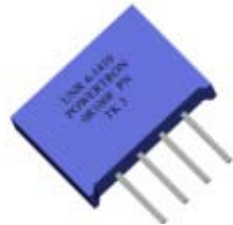

- Highest Stability
- Near Temperature Independence
- Lowest Tolerances
- Low Capacitance And Inductance
- Customized Resistance Values

SPECIFICATIONS

ELECTRICAL

	USR 4-1410	UNR 4-1410 note ¹⁾
Resistance Range	: 0R1...100R	
Power Rating	: 0.8 W (70°C)	
Tolerance	:	
from 0R1	: 0.1%, 0.25%, 0.5%, 1%	
from 10R	: 0.05%, 0.1%, 0.25%, 0.5%, 1%	
from 50R	: 0.01%, 0.02%, 0.05%, 0.1%, 0.25%, 0.5%, 1%	
Stability	: 0.01%	
Temperature Coefficient	: max. ±5 ppm/K (-55...155)°C typ. ±3 ppm/K (-55...125)°C upon request ±1 ppm/K (0...60)°C	
Insolation Resistance	: > 10 GOhm	
Thermal EMF	: < 1 µV/K	

ENVIRONMENTAL

Operative Temperature Range : -55°C...155°C

MECHANICAL

Resistor Material	: NiCr-Foil	
Substrate	: Al ₂ O ₃	AIN
Housing	: PBTP / Epoxy	
Connector Material	: Cu tinned, 4-pin	

note¹⁾: Specially designed for applications with fast changing electrical load.

TEMPERATURE COEFFICIENT

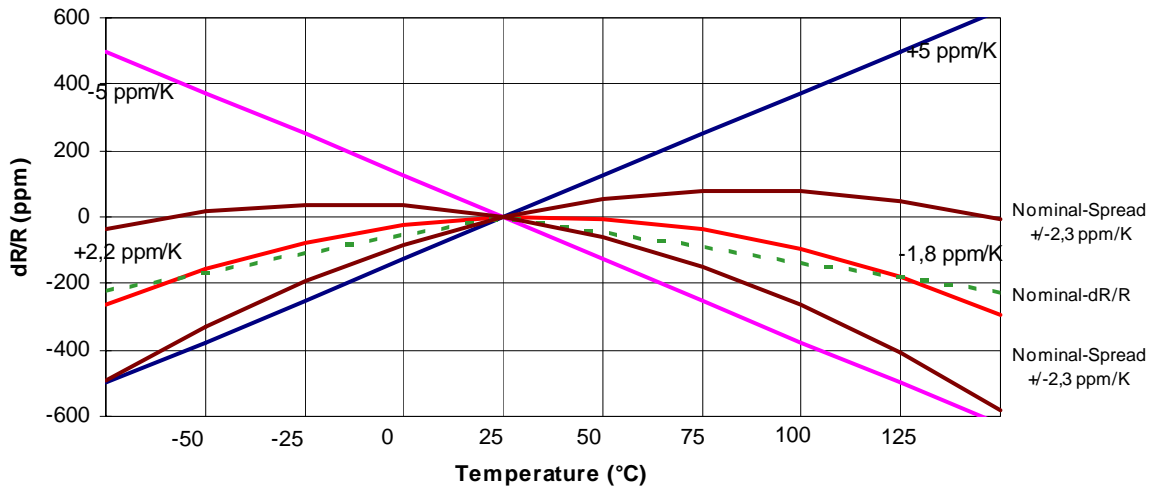

DERATING CURVE

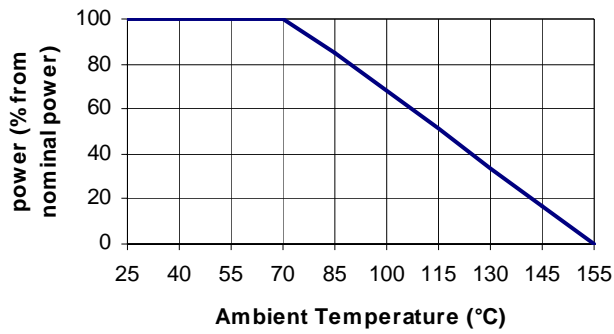

DIMENSIONS

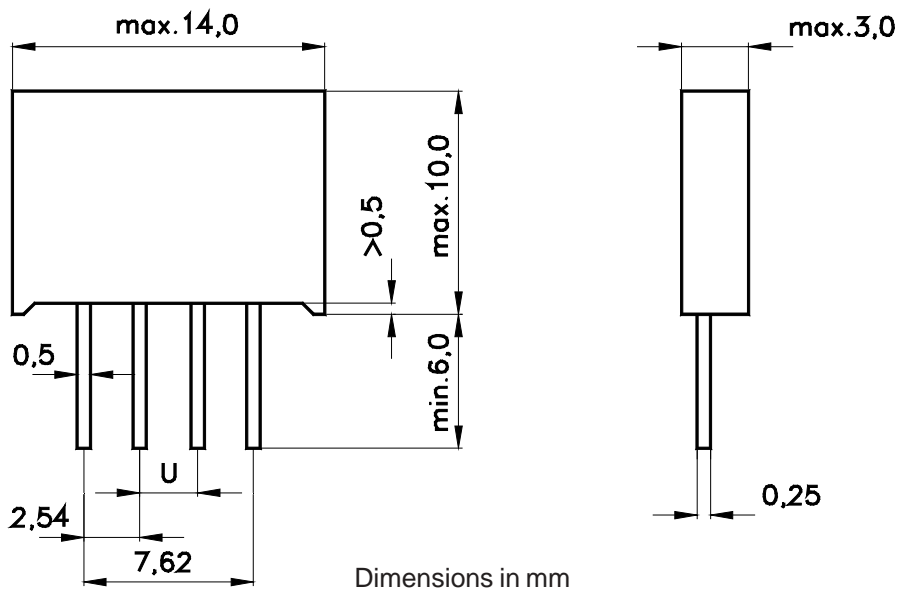

HOW TO ORDER

USR 4-1410 10R X 0.1% TK1

UNR 4-1410 0R1 X 0.5% TK3

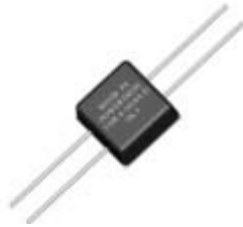

- **Highest Stability**
- **Near Temperature Independence**
- **Lowest Tolerances**
- **Low Capacitance and Inductance**
- **Customized Resistance Values**

SPECIFICATIONS

ELECTRICAL

Resistance Range	:	0R5 ... 100R
Power Rating	:	0.8 W without heatsink (70°C) 25 W with heatsink
Thermal Resistance Rthj-c	:	< 4.2 K/W
Tolerances	:	
from 0R5	:	0.1%, 0.25%, 0.5%, 1%
from 1R	:	0.01%, 0.05%, 0.1%, 0.25%, 0.5%, 1%
Stability	:	0.01%
Temperature Coefficient	:	max. ±5 ppm/K (-55...155)°C typ. ±3 ppm/K (-55...125)°C upon request ±1 ppm/K (0...60)°C
Voltage Proof	:	1.5 kVDC
Thermal EMF	:	< 1 µV/K

ENVIRONMENTAL

Operating Temperature Range	:	-55°C...155°C
------------------------------------	---	---------------

MECHANICAL

Resistor Material	:	NiCr-Foil
Substrate	:	Al ₂ O ₃ (upon request AlN)
Housing	:	Plastic + Epoxy
Connector Material	:	Cu-tinned / 4-pin

TEMPERATURE COEFFICIENT

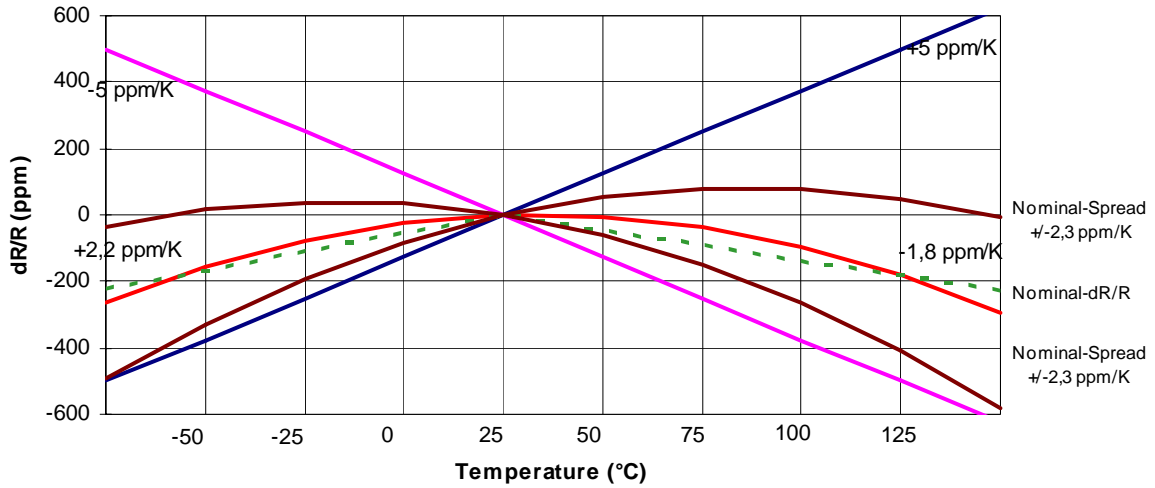

DERATING CURVE

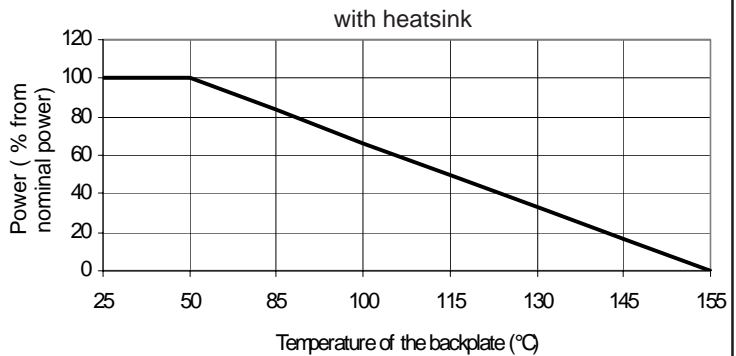
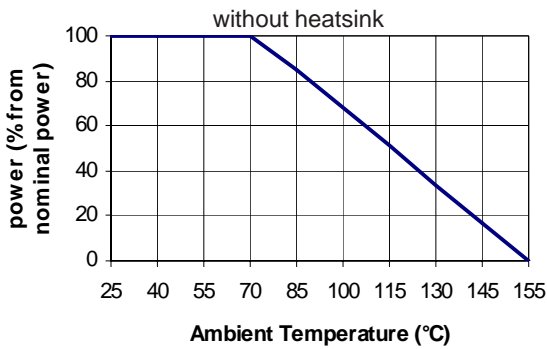

DIMENSIONS

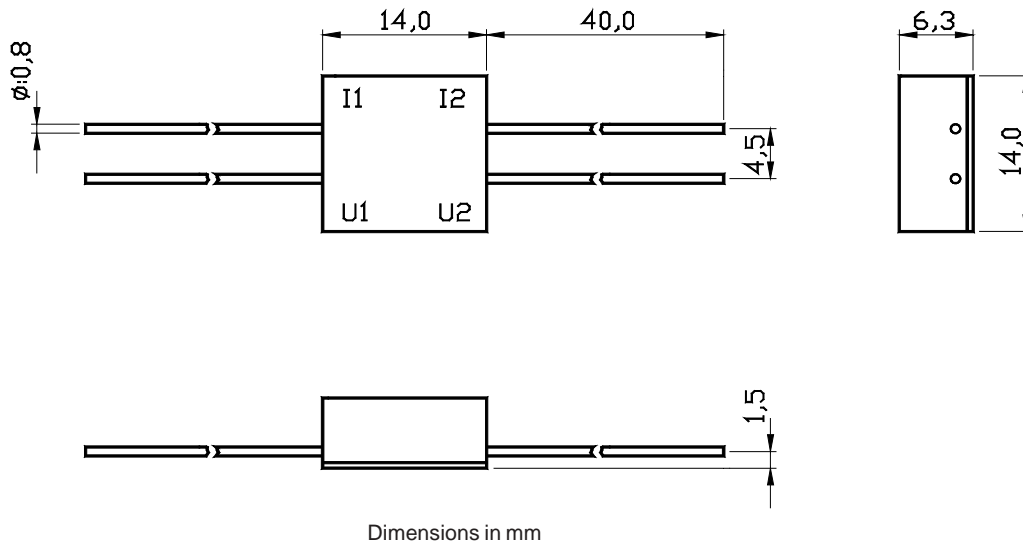

HOW TO ORDER

USR 4-1414 1R5 0.1% TK3

USR 4-1414 0R1 0.1% TK3

USR UNR 4-T220 4-T220B 4-T221
USS UNS 4-T220

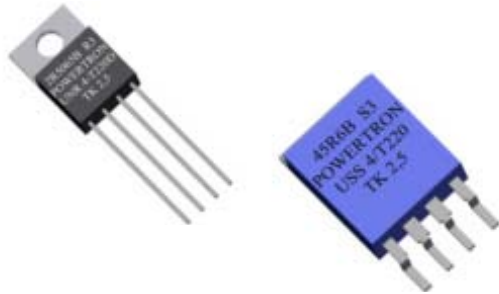

- **Highest Stability**
- **Near Temperature Independent**
- **Lowest Tolerances**
- **Low Capacitance and Inductance**
- **High Power**
- **Available also 2-pin version**

SPECIFICATIONS

ELEKTRICAL

	USR 4-T220	UNR 4-T220 note ¹⁾
Resistance range	: 0R2...80R	0R2...80R
Nominal power	: 1.5 W (70°C) without heatsink 10 W* * with heatsink	15 W*
Thermal Resistance Rthj-c	: 10.8 K/W	6.8 K/W
Tolerances	:	
from 0R5	: 0.1%, 0.25%, 0.5%, 1%	
from 10R	: 0.05%, 0.1%, 0.25%, 0.5%, 1%	
from 50R	: 0.01%, 0.02%, 0.05%, 0.1%, 0.25%, 0.5%, 1%	
Stability	: 0.01%	
Temperature coefficient	: max. ±5 ppm/K (-55...155)°C typ. ±3 ppm/K (-55...125)°C upon request ±1 ppm/K (0...60)°C	
Voltage Proof	: 1 kVDC	
Thermal EMF	: < 1 µV/K	

ENVIRONMENTAL

Operating Temperature Range : -55°C...155°C

MECHANICAL

Resistor Material	: NiCr-Foil	
Substrate	: Al ₂ O ₃	AlN
Housing	: Epoxy + heatsink Cu nickel plated	
Connector Material	: Cu, tinned, 4-pin	
Max. torque backplate	: 1.0 Nm	

note¹⁾: Specially designed for applications with fast changing electrical load.

TEMPERATURE COEFFICIENT

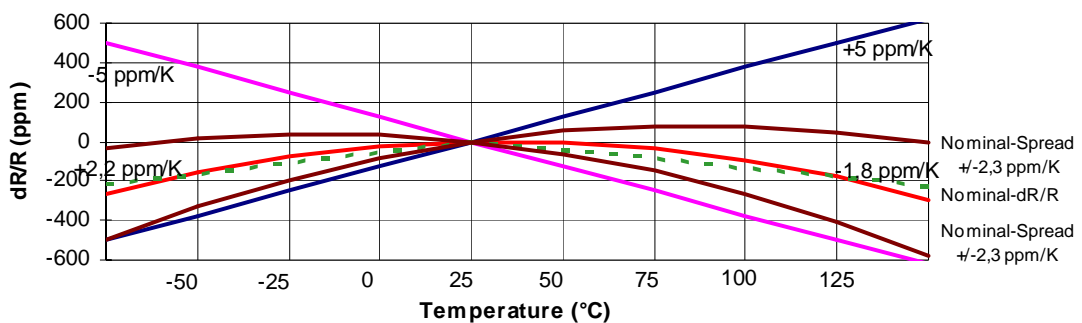

USR UNR 4-T220 4-T220B 4-T221
USS UNS 4-T220



DERATING CURVE

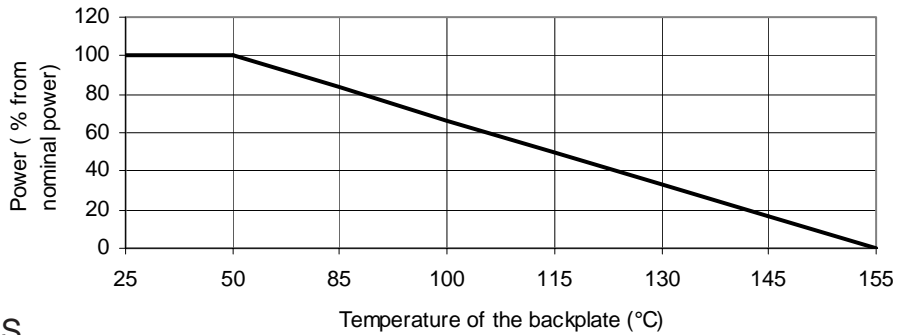

DIMENSIONS

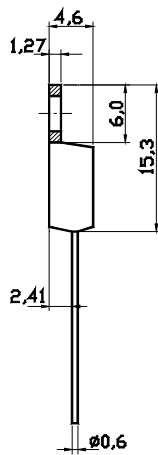
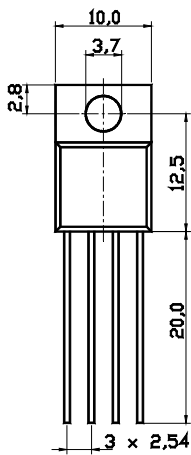

USR 4-T220
UNR 4-T220

Housing for special demands and small quantities

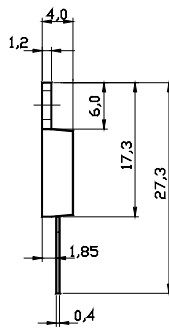
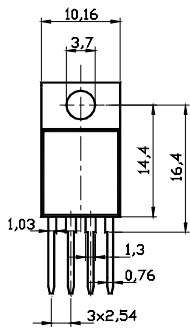

USR 4-T220B / UNR 4-T220B

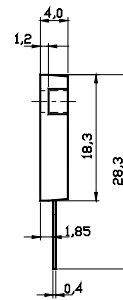
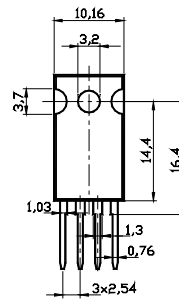

USR 4-T221 / UNR 4-T221

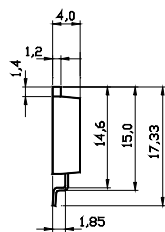
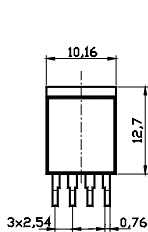

USS 4-T220 / UNS 4-T220

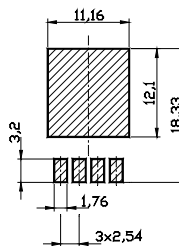

Dimensions in mm

HOW TO ORDER

USR 4-T220 0R5 D 0.25% TK5

UNR 4-T220B 50R D 0.1% TK1



- High Stability
- Near Temperature Independence
- Lowest Tolerances
- Low Capacitance and Inductance
- Customized Resistance Values

SPECIFICATIONS

ELECTRICAL

	USR 4-3425/3825 with additional heatsink 3825H	UNR 4-3425/3825 note ¹⁾
Resistance Range :	0R05 ... 500R other resistance values upon request / power rating depending on resistor value	0R05 ... 500R
Power Rating :	3 W (70°C) without heatsink 5 W (20°C) for 3825H 30 W* * with heatsink	50 W*
Thermal Resistance Rthj-c :	3.5 K/W	2.1 K/W
Tolerances :		
from 0R05 :	0.1%, 0.25%, 0.5%, 1%	
from 10R :	0.05%, 0.1%, 0.25%, 0.5%, 1%	
from 50R :	0.01%, 0.02%, 0.05%, 0.1%, 0.25%, 0.5%, 1%	
Stability :	0.01%	
Temperature Coefficient :	max. ±5 ppm/K (-55...155)°C typ. ±3 ppm/K (-55...125)°C upon request ±1 ppm/K (0...60)°C	
Voltage Proof :	750 VDC	
Max. Current :	15 A	
Thermal EMF :	< 1 µV/K	

ENVIRONMENTAL

Operating Temperature Range : -55°C...155°C

MECHANICAL

Resistor Material :	NiCr-Foil	
Substrate :	Al ₂ O ₃	AlN
Housing :	Epoxy + heatsink aluminium	
Connector Material :	Cu, tinned, 4-pin	
Max. torque backplate :	1.0 Nm	

note¹⁾: Specially designed for applications with fast changing electrical load.

USR UNR 4-4020



- **Highest Stability**
- **Nearly Temperature Independent**
- **Minimum Tolerance**
- **Low Capacity and Inductance**
- **Customized Resistor Values**

SPECIFICATIONS

ELEKTRICAL

	USR 4-4020	UNR 4-4020
Resistance Range :	0R05 ... 500R	note ¹⁾ 0R05 ... 500R
Power Rating :	other resistance values upon request / power rating depending on resistor value 2.5 W (70°C) without heatsink 30 W* * with heatsink	50 W*
Thermal Resistance Rthj-c :	3.6 K/W	2.2 K/W
Tolerances :		
from 0R05 :	0.1%, 0.25%, 0.5%, 1%	
from 10R :	0.05%, 0.1%, 0.25%, 0.5%, 1%	
from 50R :	0.01%, 0.02%, 0.05%, 0.1%, 0.25%, 0.5%, 1%	
Stability :	0.01%	
Temperature Coefficient :	max. ±5 ppm/K (-55...155)°C typ. ±3 ppm/K (-55...125)°C upon request ±1 ppm/K (0...60)°C	
Voltage Proof :	750 VDC	
Max. Current :	15 A	15 A
Thermal EMF :	<1 µV/K	

ENVIRONMENTAL

Operating Temperature Range : -55°C...155°C

MECHANICAL

Resistor Material :	NiCr-Foil	
Substrate :	Al ₂ O ₃	AlN
Housing :	Epoxy + Al-heatsink	
Connector Material :	Cu, tinned, 4-pin	
Max. torque backplate :	1.0 Nm	

note¹⁾: Specially designed for applications with fast changing electrical load.

TEMPERATURE COEFFICIENT

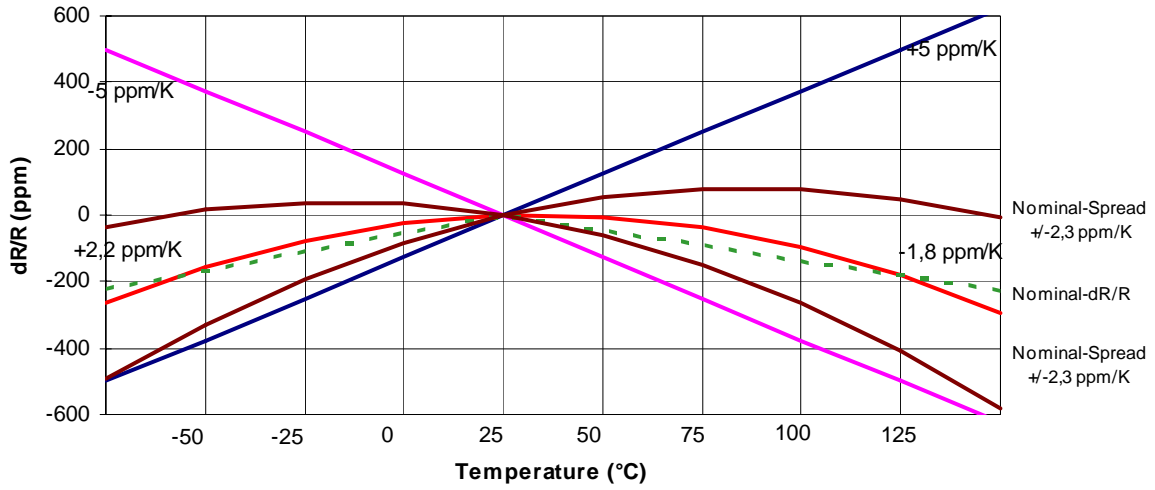

DERATING CURVE

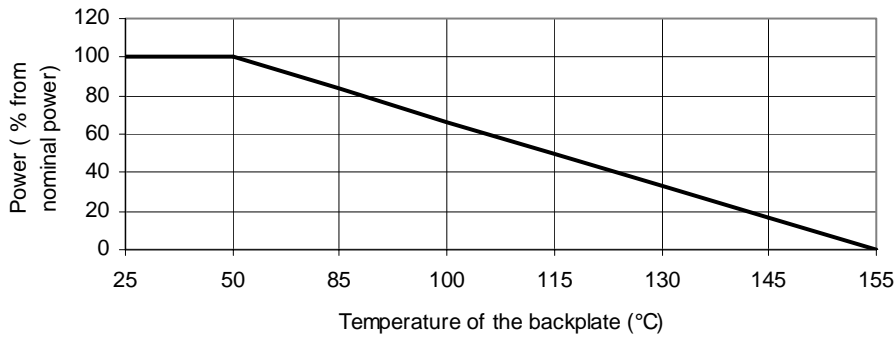

DIMENSIONS

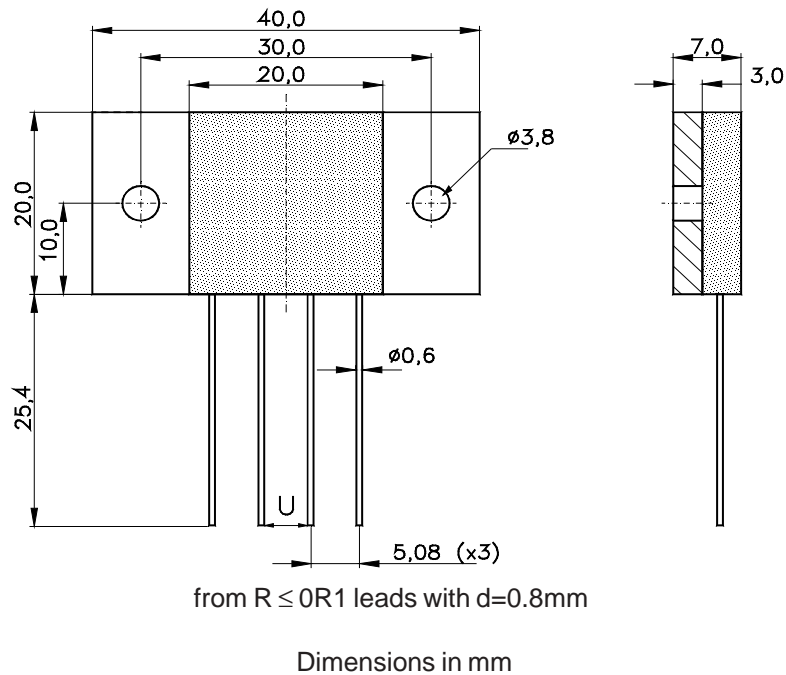

HOW TO ORDER

USR 4-4020 0R3 D 0.25% TK3

UNR 4-4020 50R D 0.01% TK1

FPR 2-1617 2-1623 2-2614

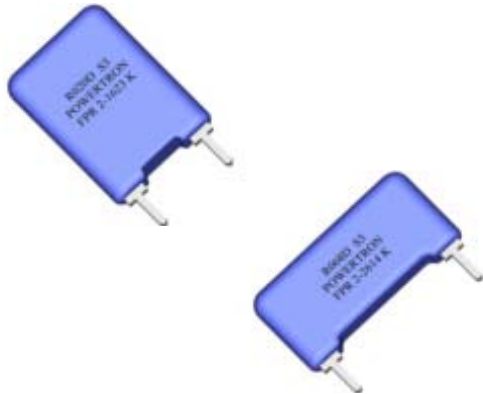

- Extremely Low-Ohm
- High Stability
- Low Temperature Coefficient
- Low Electrical Noise
- Low Inductance

SPECIFICATIONS

ELECTRICAL

	FPR 2-1617	FPR 2-1623	FPR 2-2614
Resistance Range	: R010...50R	R010...100R	R010...100R
Power Rating	: 1 W (70°C)	2 W (70°C)	2 W (70°C)
Tolerances	:		
R010	: 0.5%, 1%, 2%, 5%		
R020	: 0.25%, 0.5%, 1%, 2%, 5%		
1R0	: 0.1%, 0.25%, 0.5%, 1%, 2%, 5%		
Stability	: 0.1%, 0.2%, 0.5% (depends on stress)		
Temperature Coefficient	: R > 0R2 ±15 ppm/K (20...60)°C		
	: R ≤ 0R2 TCR see table next page		
Insolation Resistance	: > 10 GOhm		
Thermal EMF	: < 1 µV/K		

ENVIRONMENTAL

Operating Temperature Range : -40°C...130°C

MECHANICAL

Resistor Material	: Metalfoil CuNiMn (DIN 17471)
Substrate	: anodized aluminium
Housing	: Epoxy / Sintered
Connector Material	: Cu tinned, 2-pin

TEMPERATURE COEFFICIENT

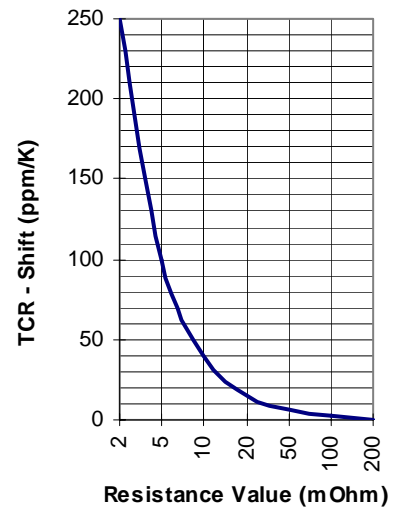
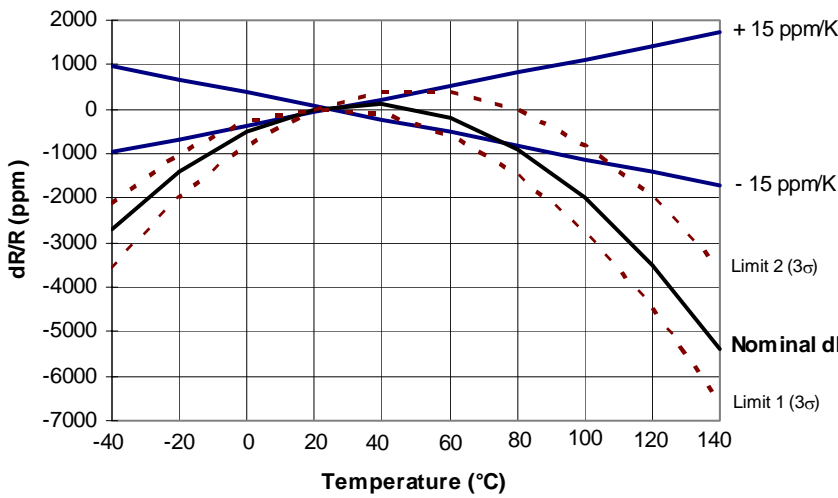

DERATING CURVE

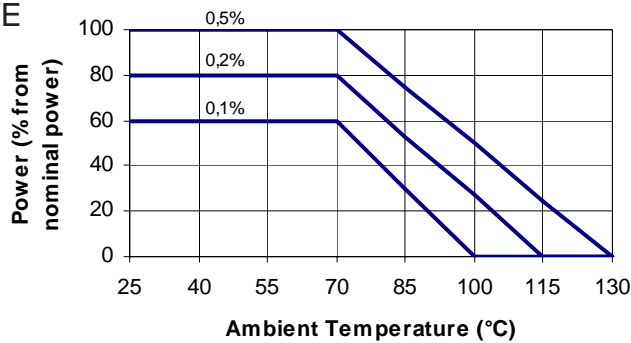

DIMENSIONS

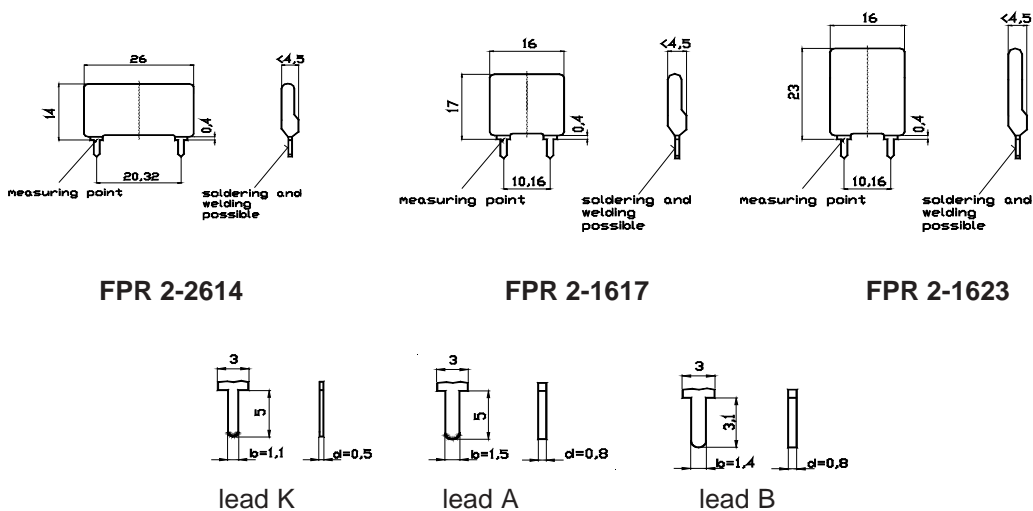

Standard leads:
 FPR2-1617/2614: for $R \geq 0P01$ lead K, for $R < 0R01$ lead A
 FPR2-1623: lead B

Dimensions in mm

HOW TO ORDER

FPR 2-2614 100R K 0.25%
 FPR 2-2614 R022 A 1.0%

FPR 2-1623 10R B 0.5%
 FPR 2-1617 R500 K 1.0%

FPR 4-2321 4-3316



- **Extremely Low-Ohm**
- **High Stability**
- **Four Circuit Technology**
- **Low Temperature Coefficient**
- **Low Electrical Noise**
- **Low Inductance**

PRODUCT DESCRIPTION

SPECIFICATIONS

ELECTRICAL

	FPR 4-2321	FPR 4-3316
Resistance Range	R0005...100R	R001...100R
Power Rating	1.5 W (70°C)	2 W (70°C)
Tolerances		
from R0005	1%, 2%, 5%	
from R005	0.5%, 1%, 2%, 5%	
from R010	0.25%, 0.5%, 1%, 2%, 5%	
from R020	0.1%, 0.25%, 0.5%, 1%, 2%, 5%	
Stability	0.1%, 0.2%, 0.5% (depends on the stress)	
Temperature Coefficient	±15 ppm/K (20...60)°C	
Insolation Resistance	> 10 GOhm	
Thermal EMF	< 1 µV/K	

ENVIRONMENTAL

Operating Temperature Range : -40°C...130°C

MECHANICAL

Resistor Material	:	Metalfol CuNiMn (DIN 17471)
Substrate	:	anodized aluminium
Housing	:	Epoxy / Sintered
Connector Material	:	Cu tinned 4-pin

TEMPERATURE COEFFICIENT

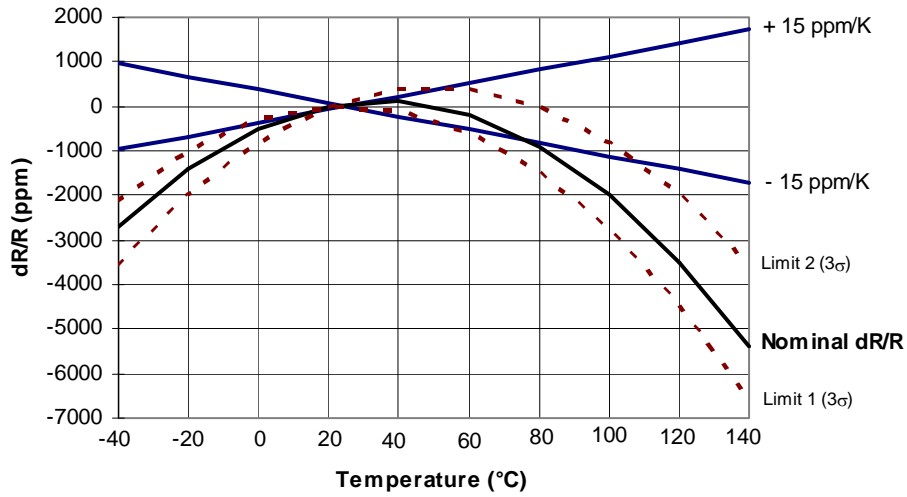

DERATING CURVE

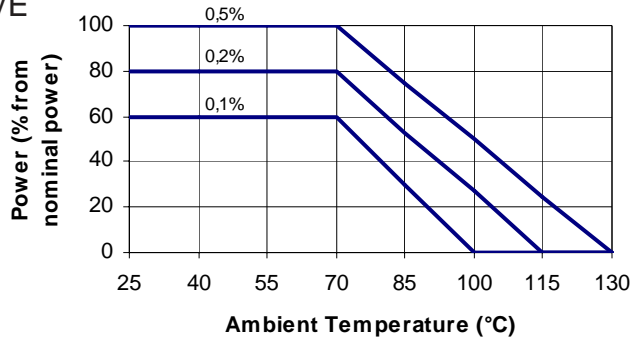

DIMENSIONS



FPR 4-3316

FPR 4-2321

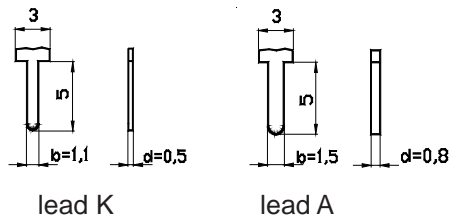

Standardleads:
 FPR2-3316: for $R > 0R01$ lead K, for $R < 0R01$ lead A
 Dimensions in mm

HOW TO ORDER

FPR 4-2321 10R 0.5%
 FPR 4-2321 R022 1.0%

FPR 4-3316 100R K 1%
 FPR 4-3316 0R01 A 1.0%

FPR 2-T218



- Extremely Low-Ohm
- High Stability
- Low Temperature Coefficient
- Low Electrical Noise
- Low Inductance
- TO-Standard-Housing

SPECIFICATIONS

ELECTRICAL

FPR2-T218

Resistance Range	:	R002...50R Serie E12
Power Rating	:	2 W (70°C) 30 W with heatsink
Thermal Resistance Rthj-c	:	2.5 K/W
Tolerances	:	
from R002	:	1%, 2%, 5%
from R010	:	0.5%, 1%, 2%, 5%
from R020	:	0.25%, 0.5%, 1%, 2%, 5%
from 1R0	:	0.1%, 0.25%, 0.5%, 1%, 2%, 5%
Stability	:	0.1%, 0.2%, 0.5% (depends on stress)
Temperature Coefficient	:	R > 0R2 ±15 ppm/K (20...60)°C R ≤ 0R2 TCR see table next page
Voltage Proof	:	300 VDC
Thermal EMF	:	< 1 µV/K

ENVIRONMENTAL

Operating Temperature Range : -40°C...130°C

MECHANICAL

Resistor Material	:	Metalfoil CuNiMn (DIN 17471)
Substrate	:	anodized aluminium
Housing	:	PPS
Connector Material	:	Cu tinned, 2-pin
Max. torque backplate	:	1 Nm

TEMPERATURE COEFFICIENT

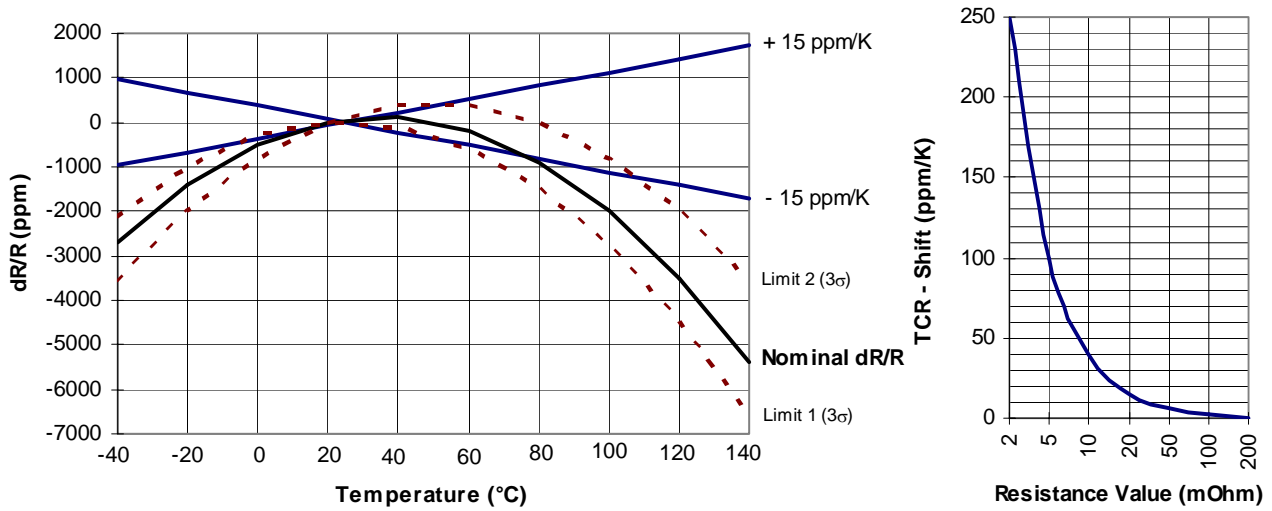

DERATING CURVE

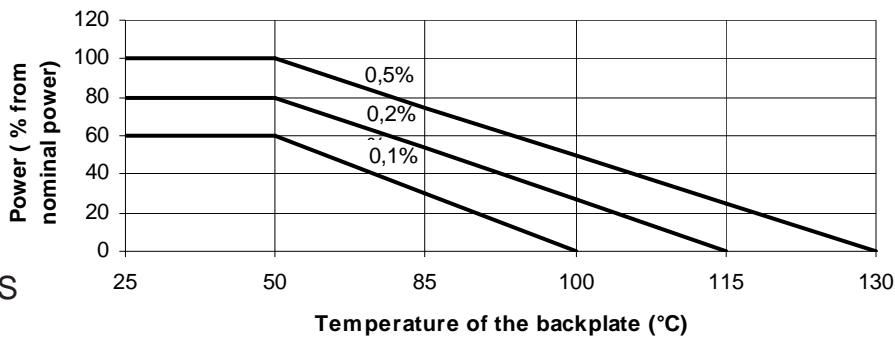

DIMENSIONS

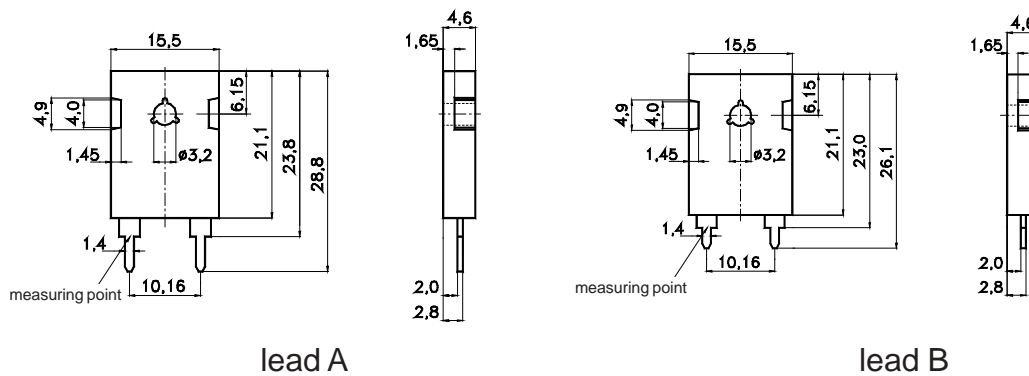

Standardlead for T-218 : Lead B

Dimensions in mm

HOW TO ORDER

FPR 2-T218 10R B 0.25%
 FPR 2-T218 R068 B 0.5%

FPR 2-T218 10R0 B 1.0%
 FPR 2-T218 R068 A 0.5%

FPR / FPS

2-T220 4-T220 2-T221 4-T221



- Extremely Low-Ohm
- Small Dimensions
- High Stability
- Low Inductance
- Low Electrical Noise
- Low Temperature Coefficient
- TO220-Housing
- SMD available

SPECIFICATIONS

ELECTRICAL

Resistor Range	:	0R002 ... 50R
Power Rating	:	1.5 W (70°C) 15 W with heatsink
Thermal Resistance Rthj-c	:	4.8 K/W
Tolerances	:	
from 0R002	:	2%, 5% / 4-pin version also 1.0%
from 0R010	:	1%, 2%, 5% 4-pin version also 0.1% and 0.25%
from 0R100	:	0.5%, 1%, 2%, 5% 4-pin version also 0.1% and 0.25%
Stability	:	0.1%, 0.2%, 0.5% (depends on the stress)
Temperature Coefficient	:	±15 ppm/K (20...60)°C / ±50 ppm/K (-40...130)°C FPR 2-T220/221 R<0R2 TCR-Shift depends on resistor value (see table next page)
Max. Current	:	50 A
Insulation Resistance	:	300 VDC
Thermal EMF	:	< 1 µV/K

ENVIRONMENTAL

Operating Temperature	:	-40°C...130°C
------------------------------	---	---------------

MECHANICAL

Resistor Material	:	Metalfoil CuNiMn (DIN 17471)
Substrate	:	Al ₂ O ₃ or anodized aluminium
Housing	:	Epoxidharz or PPS
Connector Material	:	Cu tinned, 2-pin or 4-pin
Max. torque backplate	:	1 Nm / T221: 0.8 Nm

FPR / FPS

2-T220 4-T220 2-T221 4-T221



TEMPERATURE COEFFICIENT

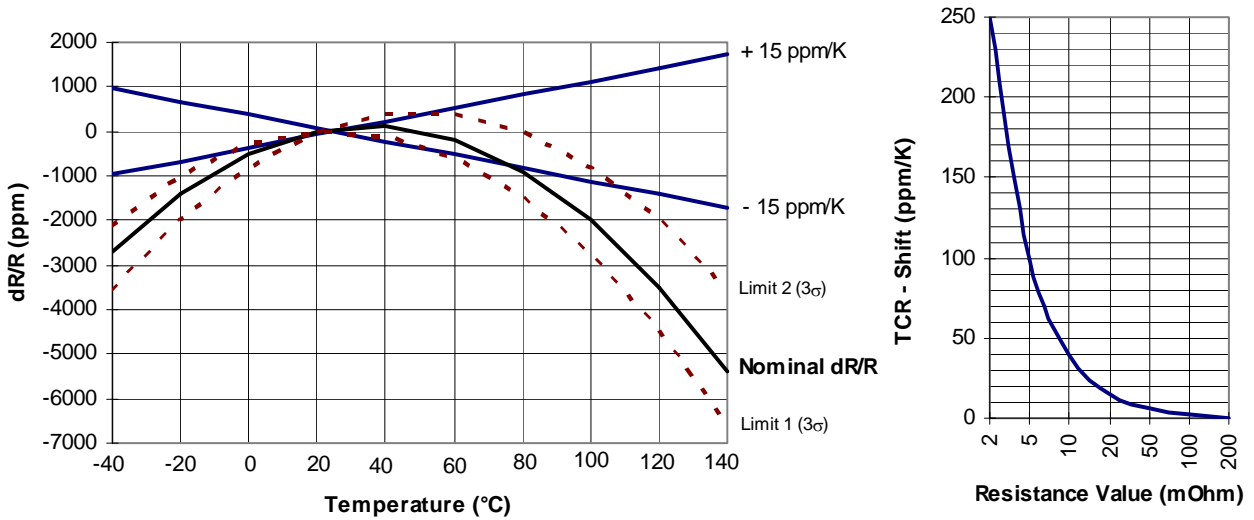

DERATING CURVE

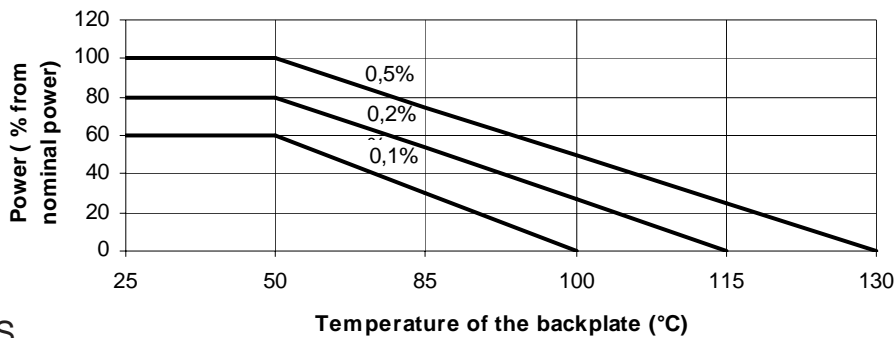

DIMENSIONS

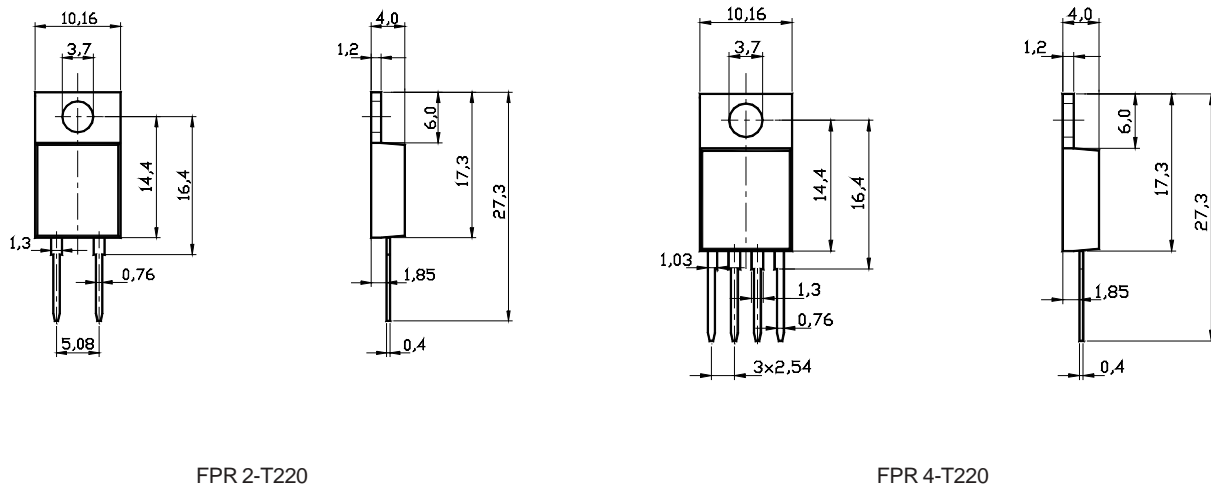

FPR 2-T220

FPR 4-T220

FPR / FPS

2-T220 4-T220 2-T221 4-T221



DIMENSIONS

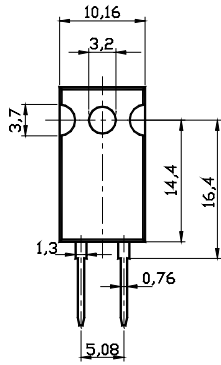

FPR 2-T221

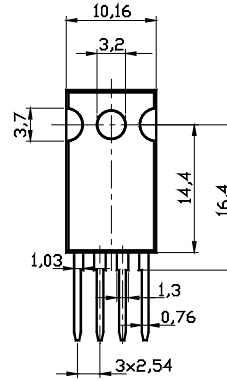
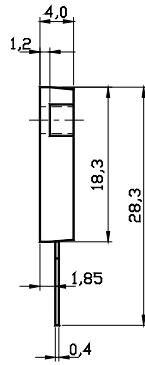

FPR 4-T221

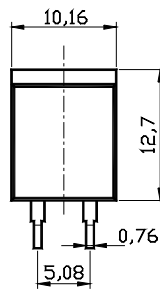
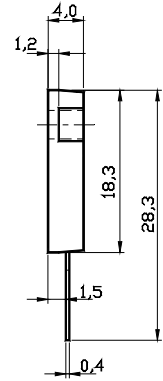

FPS 2-T220

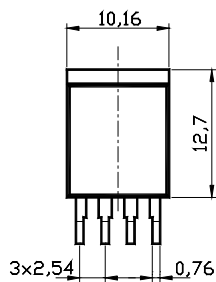
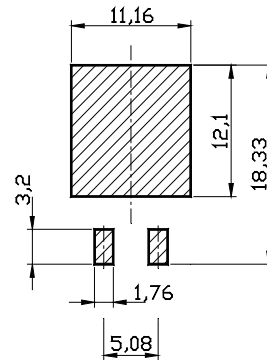
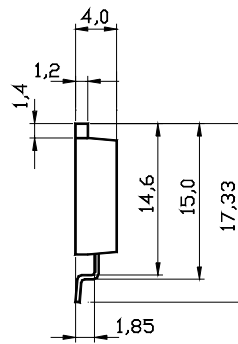

FPS 4-T220

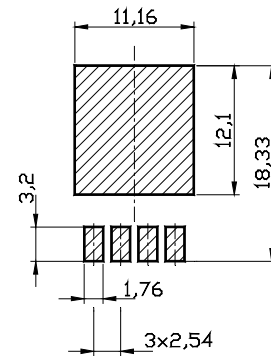
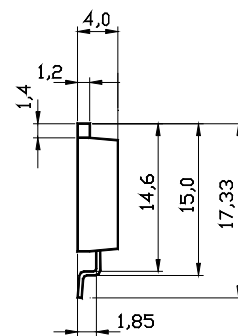

HOW TO ORDER

FPR 2-T220 10R 0.25%
FPR 2-T221 0R068 0.5%

FPS 2-T220 1R0 1%
FPR 4-T221 0R1 0.5%

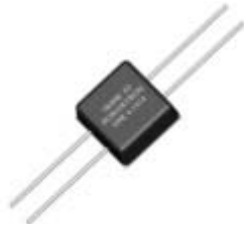

- **Extremely Low-Ohm**
- **Highest Stability**
- **Low Temperature Coefficient**
- **Low Electrical Noise**
- **Low Inductance**
- **Customized Resistor Values**

SPECIFICATIONS

ELECTRICAL

Resistance Range	:	0R01 ...1R
Power Rating	:	0.8 W without heatsink (70°C) 25 W with heatsink
Thermal Resistance Rthj-c	:	< 4.2 K/W
Tolerances	:	0.1%, 0.25%, 0.5%, 1%
Stability	:	0.1%, 0.2%, 0.5% (depends on stress)
Temperature Coefficient	:	±10 ppm/K (20...40)°C ±15 ppm/K (20...60)°C ±50 ppm/K (-40...130)°C
Insolation Resistance	:	1.5 kVDC
Max. Current	:	20 A
Thermal EMF	:	< 1 µV/K

ENVIRONMENTAL

Operating Temperature Range : -40°C...130°C

MECHANICAL	Resistor Material	:	CuNiMn-Foil
	Substrate	:	Al ₂ O ₃ (optional AlN)
	Housing	:	Plastic / Epoxy
	Connector Material	:	Cu-tinned / 4-pin

TEMPERATURE COEFFICIENT

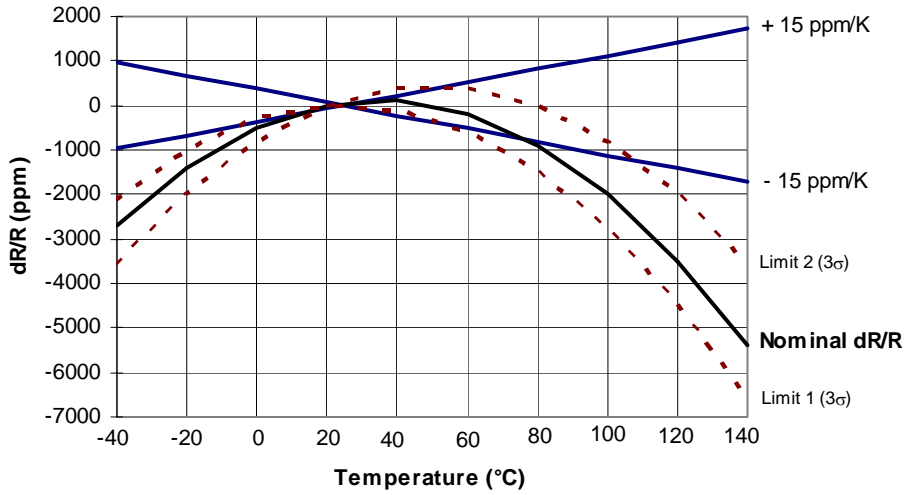

DERATING CURVE

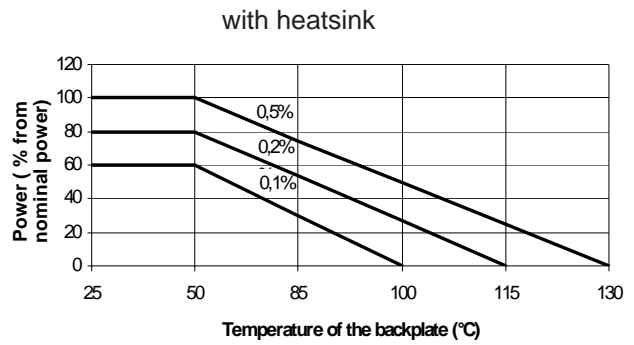
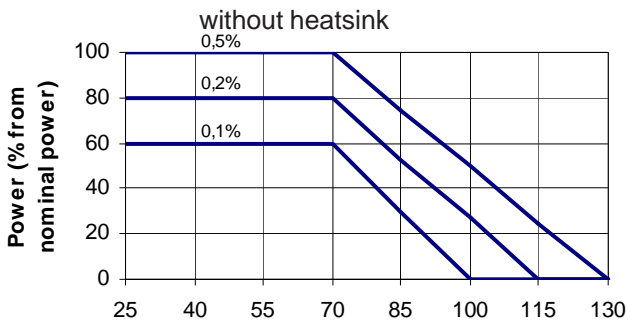

DIMENSIONS Ambient Temperature (°C)

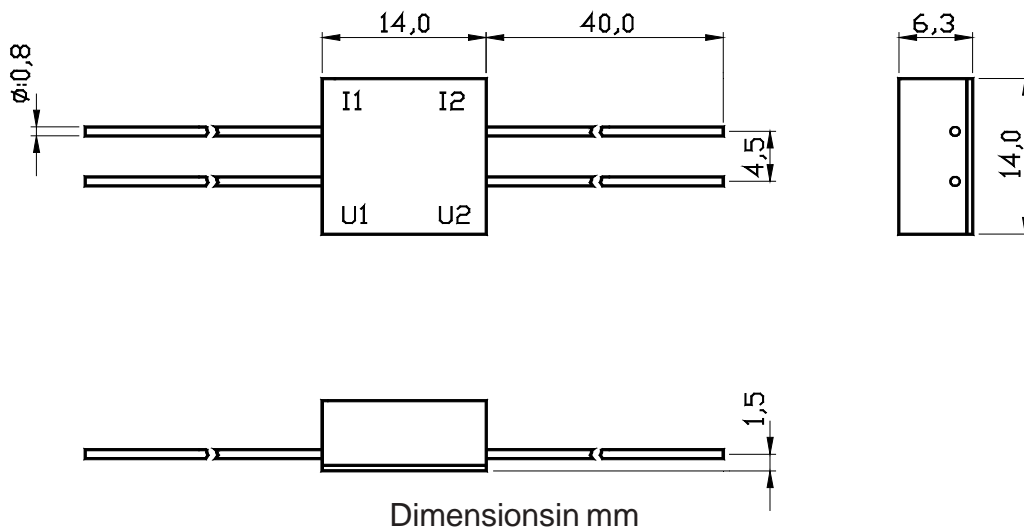

HOW TO ORDER

FPR 4-1414 0R05 D 0.5%

FPR 4-1414 0R01 D 0.1%

FHR 2-3025 2-3818 4-4618 4-3825 4-3825H



- High Power
- Extremely Low-Ohm
- High Stability
- Kelvin Connection
- Low Temperature Coefficient
- Low Inductance

SPECIFICATIONS

ELECTRICAL

	FHR 2-3025/2-3818	FHR 4-3825H 4-3825/4-4618
Resistance Range	: R010...100R	R001...100R
Power Rating	: 3 W (70°C) without heatsink (5 W for FHR4-3825H) 40 W with heatsink	50 W
Thermal Resistance Rthj-c	: 2.0 K/W	1.6 K/W
Tolerances	:	:
from R001	:	1.0%, 2%, 5%
from R005	:	0.5%, 1%, 2%, 5%
from R010	: 0.5%, 1%, 2%, 5%	0.1%, 0.25%, 0.5%, 1%, 2%, 5%
from R020	: 0.25%, 0.5%, 1%, 2%, 5%	0.1%, 0.25%, 0.5%, 1%, 2%, 5%
Stability	: 0.1%, 0.2%, 0.5% (depends on stress)	
Temperature Coefficient	: ±15 ppm/K (20 ... 60)°C ±25 ppm/K (20 ... 60)°C with contact F FHR 2-3025/3818 TCR Shift (see table next page)	
Voltage Proof	: 500 VDC	
Thermal EMF	: 1 µV/K	
Max. Current	: 150 A / 200 A (contact F)	

ENVIRONMENTAL

Operating Temperature Range : -40°C...130°C

MECHANICAL

Resistor Material	: Metalfoil CuNiMn (nach DIN 17471)
Substrate	: anodized aluminium
Housing	: Epoxy
Connector Material	: Cu tinned, 2- and 4-pin
Max. torque backplate	: 1Nm

TEMPERATURE COEFFICIENT

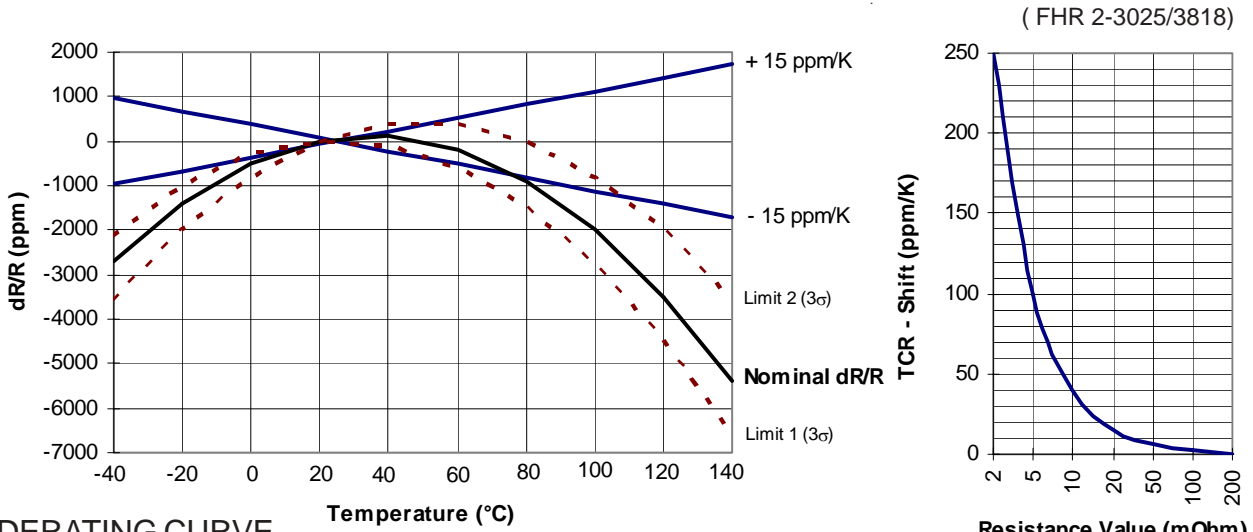

DERATING CURVE

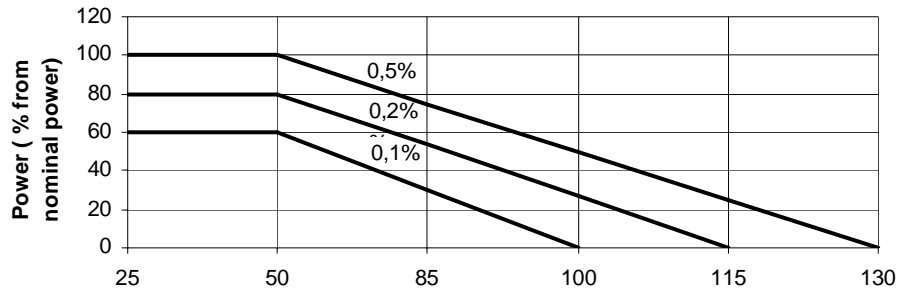

DIMENSIONS

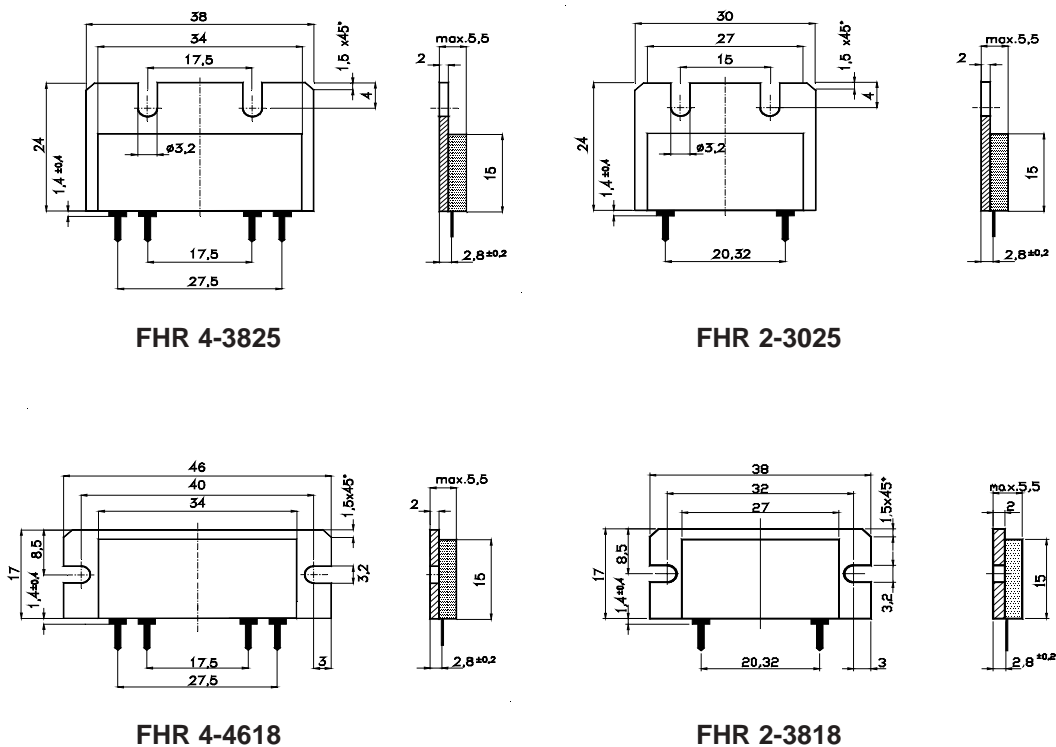

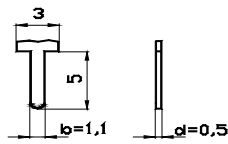

lead K
>10mOhm / 50A

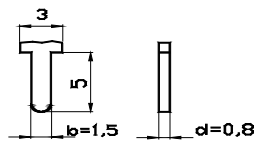

lead A
<10mOhm / 150A

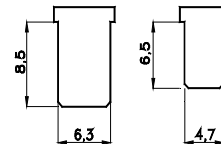

lead F
200A

SPECIAL HOUSINGS

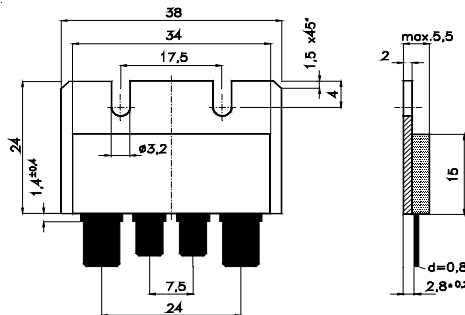

FHR 4-3825 F

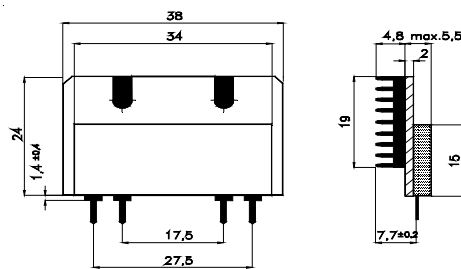

FHR 4-3825H

Dimensions in mm

HOW TO ORDER

FHR 4-3825 10R0 K 0.25%
FHR 4-3825H R010 A 0.5%

FHR 4-3825 R001 F 1%
FHR 4-4618 R050 A 1%

FHR FNR 2-T238 4-T238



- Extremely Low-Ohm
- High Stability
- Two And Four Circuit Technology
- Low Temperature Coefficient
- Low Electrical Noise
- Low Inductance

SPECIFICATIONS

ELECTRICAL

	FHR 2/4-T238	FNR 2/4-T238
Resistance Range	: R01/R001...100R	R01R001...100R
Power Rating	: 60 W* *with heatsink	80 W*
Thermal Resistance Rthj-c	: 1.3 K/W	1.0 K/W
Tolerances	: 0.5%, 1%, 2%, 5% (others upon request)	
Stability	: 0.1%, 0.2%, 0.5% (depends on stress)	
Temperature Coefficient	: ± 15 ppm/K (20... 60)°C FHR/FNR2-238 TCR-Shift (see table next page)	
Voltage Proof	: 2.5 kV DC	
Thermal EMF	: < 1 μ V/K	
Max. Current	: 40 A	45 A higher upon request

ENVIRONMENTAL

Operating Temperature Range : -40°C...130°C

MECHANICAL

Resistor Material	: Metalfoil CuNiMn (nach DIN 17471)
Substrate	: Al ₂ O ₃ AIN
Housing	: Epoxy
Connector Material	: Cu tinned, 2- and 4-pin

TEMPERATURE COEFFICIENT

FHR/FNR 2-T238

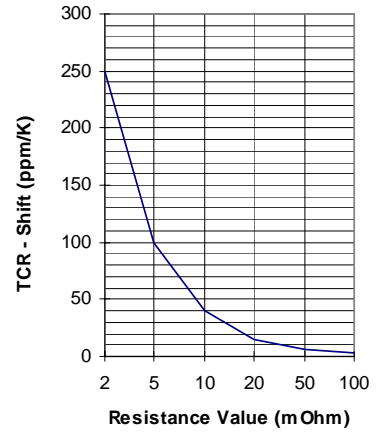
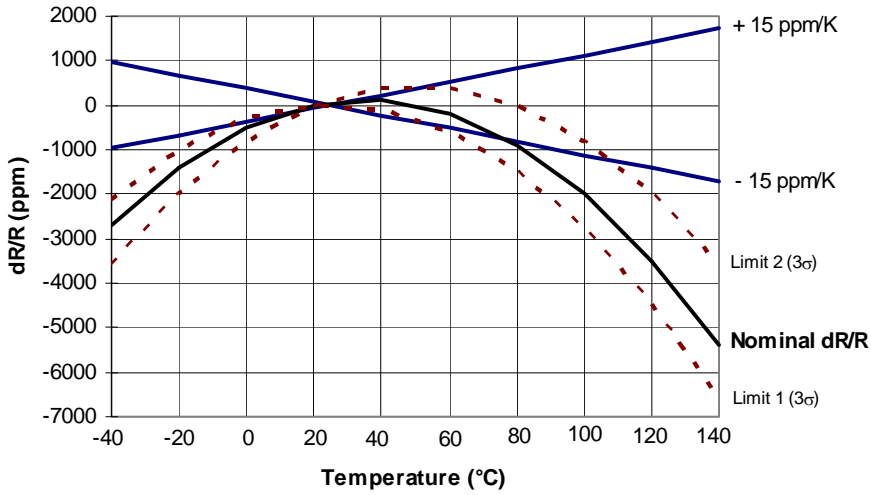

DERATING CURVE

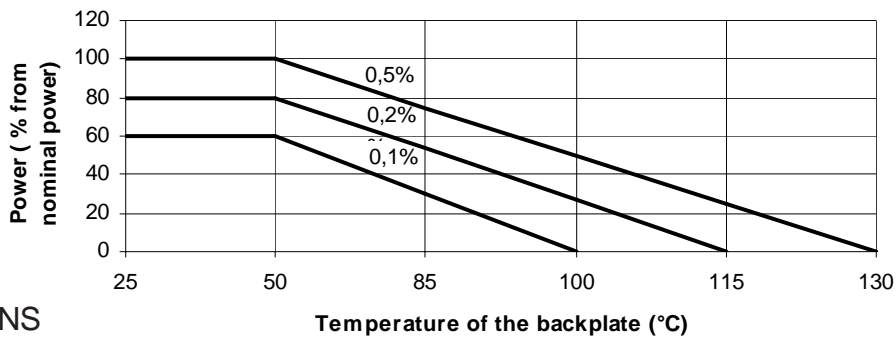

DIMENSIONS

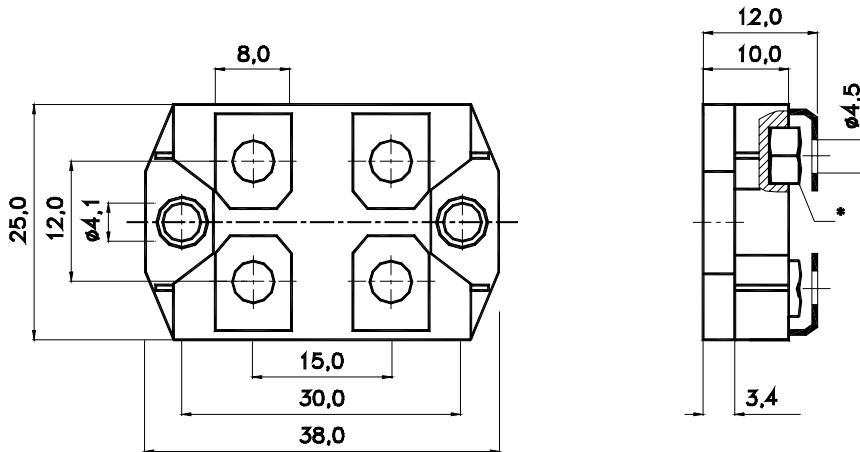

* screw terminal M4

Standard: Pin G (width= 6.35) leads curved

Dimensions in mm

ATTACHMENT VARIATIONS

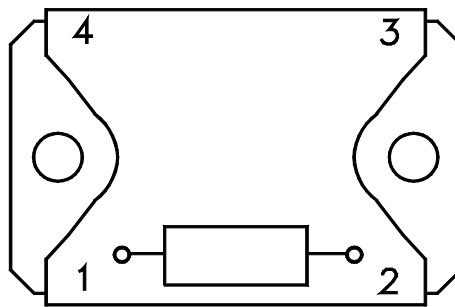

FHR 2-T238 / FNR 2-T238

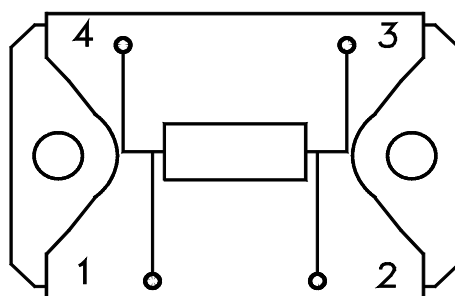

FHR 4-T238 / FNR 4-T238

1 - U1 3 - I2
2 - U2 4 - I1

Dimensions in mm

HOW TO ORDER

FHR 2-T238 1R1 G 1%

FNR 4-T238 R001 F 2%

FPR FNR 2-T227 4-T227



- Extremely Low-Ohm
- High Stability
- Two And Four Circuit Technology
- Low Temperature Coefficient
- Low Electrical Noise
- Low Inductance

SPECIFICATIONS

ELECTRICAL

	FPR 2/4-T227	FNR 2/4-T227
Resistance Range	: R01/R001 ...100R	R01/R001 ...100R
Power Rating	: 60 W * * with heatsink	80 W *
Thermal Resistance Rthj-c	: 1.3 K/W	1.0 K/W
Tolerances	: 0.5%, 1%, 2%, 5% (others upon request)	
Stability	: 0.1%, 0.2%, 0.5% (depends on stress)	
Temperature Coefficient	: ±15 ppm/K (20...60)°C from R < R02 ±20 ppm/K (20...60)°C FPR/FNR 2-T238 TK-Shift depends from resistance value (see next page)	
Voltage Proof	: 2.5 kV DC	
Thermal EMF	: < 1 µV/K	
Max. Current	: 50 A (higher upon request)	50 A

ENVIRONMENTAL

Operating Temperature Range : -40°C...130°C

MECHANICAL

Resistor Material	: Metalfoil CuNiMn (DIN 17471)
Substrate	: Al ₂ O ₃ AIN
Housing	: Epoxidharz
Connector Material	: Cu, tinned, 2-pol / 4-pol
Max. Torque	: backplate: 1.5 Nm terminals: 1.3 Nm

TEMPERATURE COEFFICIENT

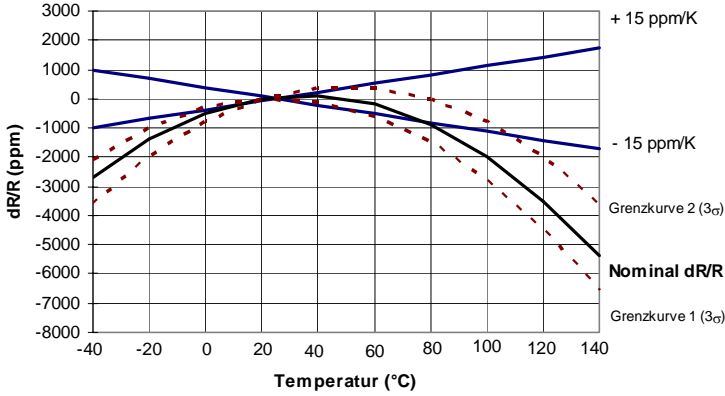

two-terminal versions
(FHR/FNR 2-T227)

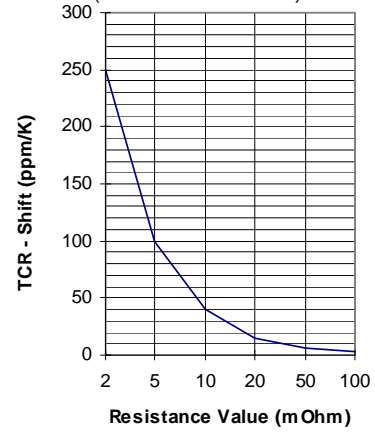

DERATING CURVE

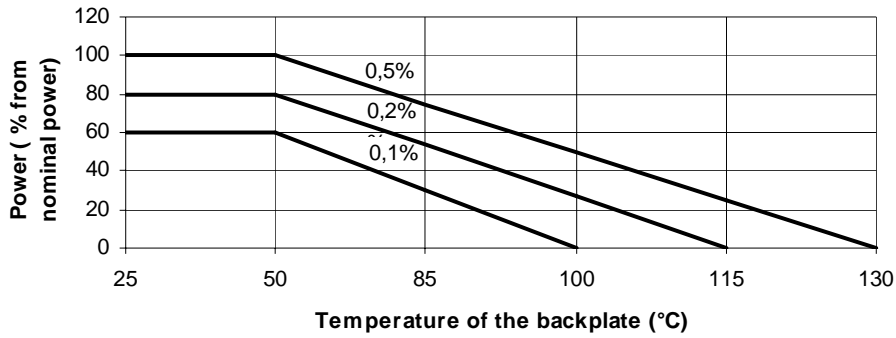

DIMENSIONS

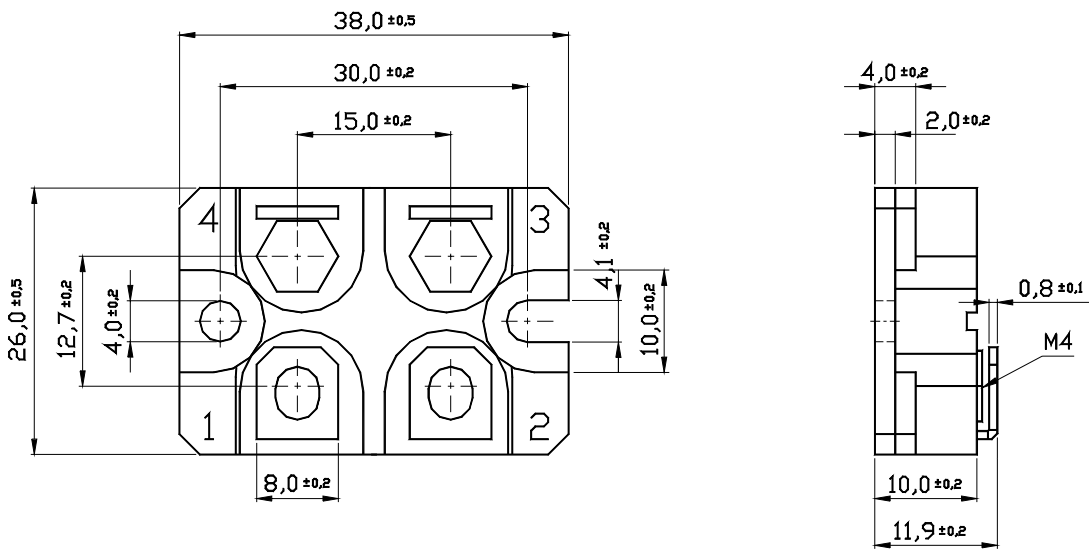

Standardkontakt: G

Dimensions in mm

ATTACHMENT VARIATIONS

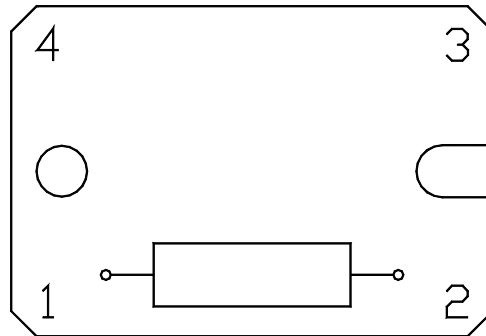

FPR 2-T227 / FNR 2-T227

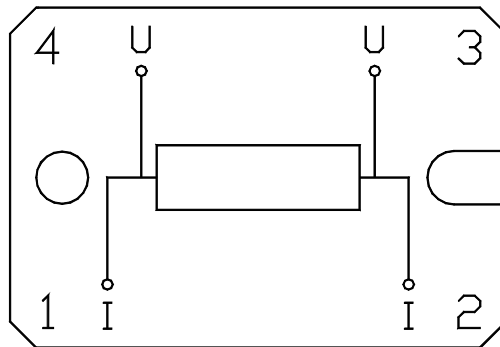

FPR 4-T227 / FNR 4-T227

HOW TO ORDER

FPR 2-T227 1R1 G 1%

FNR 4-T227 R001 G 2%

**FHR 4-8065 4-80110 4-80216
4-80320 4-80370**



- **Power Rating from to 2500 W**
- **High Stability**
- **Low TCR**
- **Low Inductance**
- **Low Noise**

SPECIFICATIONS

ELECTRICAL

FHR 4-8065 / 80110 / 80216 / 80320 / 80370

Resistance Range : R001 ...500R (FHR 4-8065 up to 400R)
Power Rating : 350 W / 600 W / 1200 W / 2000 W / 2500 W
with heatsink
24 W / 32 W / 60 W / 80 W / 90 W
without heatsink (25°C)

Thermal Resistance Rthj-c : 0.16 / 0.09 / 0.04 / 0.026 / 0.022 K/W

Tolerances :
from R001 : 0.5%, 1%, 2%, 5%
from R005 : 0.5%, 1%, 2%, 5%
from R010 : 0.25%, 0.5%, 1%, 2%, 5%
from R020 : 0.1%, 0.25%, 0.5%, 1%, 2%, 5%

Stability : 0.1%, 0.2%, 0.5% (depending on stress)

Temperature Coefficient : ±15 ppm/K (20...60)°C
from R < R02 ±20 ppm/K (20...60)°C
from R < R01 ±30 ppm/K (20...60)°C
for 2-pin type TCR-Shift depends on resistor value
(see next page)

Inductivity : < 50 nH
Capacity against housing : 500 pF / 850 pF / 1.7 nF / 2.5 nF / 2.9 nF
Insulation Strenght : 1.5 kVDC (higher upon request)
Thermal EMF : < 1 µV/K
Max. current : Standard cable 60 A
(Special contact up to 250 A)

ENVIRONMENTAL

Operating Temperature Range : -40°C ... 130°C

MECHANICAL Resistor Material : Metalfoil CuNiMn (DIN 17471)
Substrate : anodized Aluminium
Housing : anodized Aluminium
Connection : Cu-Cable, 4 mm², 500 mm lenght
(other upon request, also AWG possible)
4-pin (2-pin upon request)

TEMPERATURE COEFFICIENT

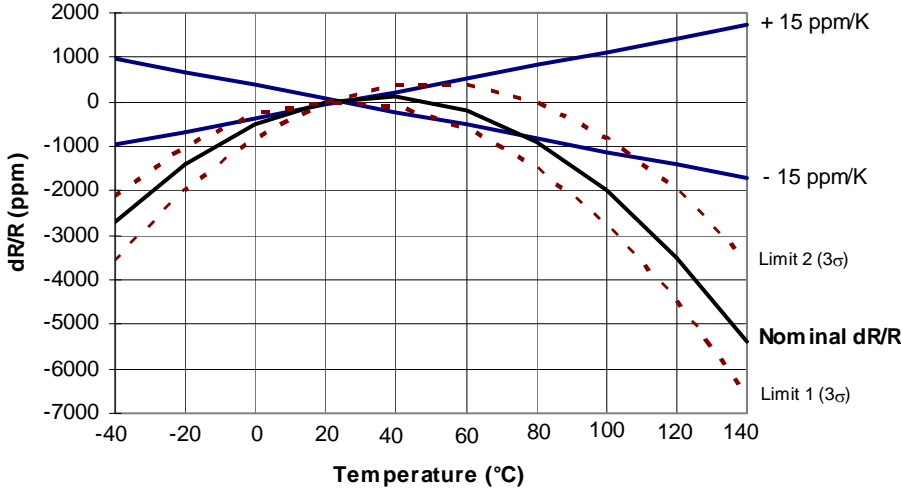

TCR-Shift for 2-pin types (FHR2-80xxx)

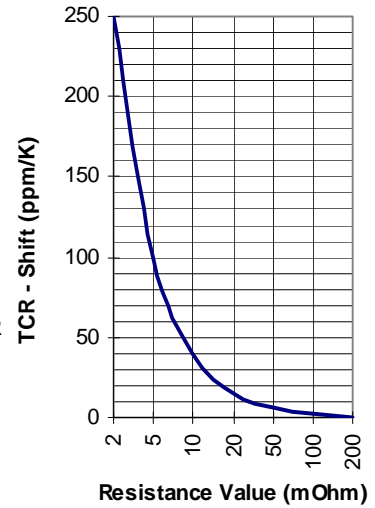

DERATING CURVE

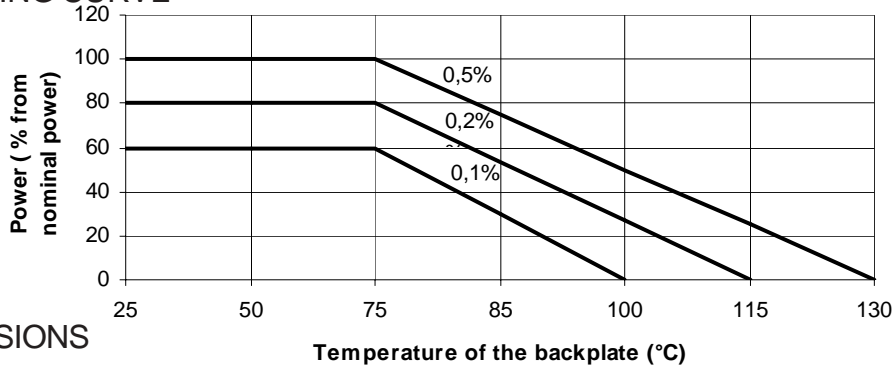

DIMENSIONS

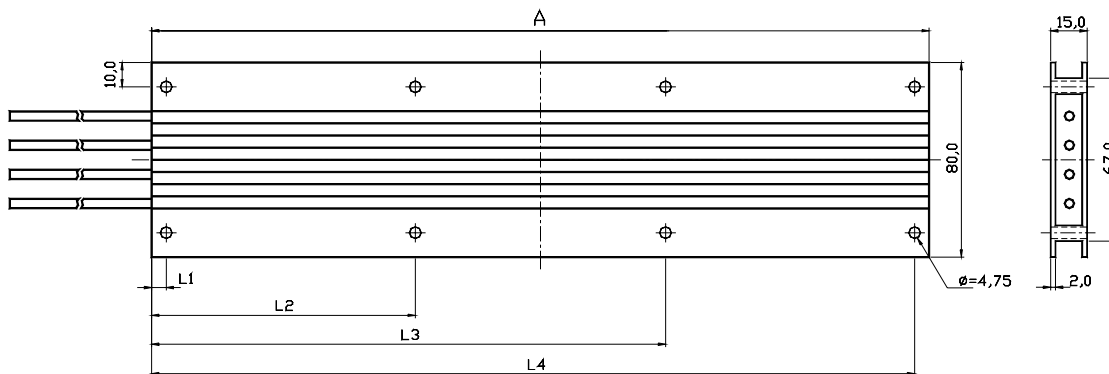

	A	L1	L2	L3	L4
FHR 4-8065	65	6,0	59,0		
FHR 4-80110	110	6,0	104,0		
FHR 4-80216	216	6,0	108,0	210,0	
FHR 4-80320	320	6,0	108,5	211,5	314,0
FHR 4-80370	370	6,0	125,5	244,5	364,0

HOW TO ORDER

FHR 4-80110 0R1 D 0.25%

FHR 4-80216 1R0 D 1%



- Power Rating from to 1000A
- High Stability
- Low Inductivity
- Low Temperature Coefficient

SPECIFICATIONS

ELECTRICAL	rated current	resistor value (at 50 mV nominal output)	P _{max}
FHR 2/4-120120	1000 A	50 μΩ	50 W
FHR 2/4-128120	750 A	67 μΩ	38 W
FHR 2/4-7580	600 A	83 μΩ	30 W
FHR 2/4-8080	500 A	100 μΩ	25 W
FHR 2/4-7050	300 A	167 μΩ	15 W
FHR 2/4-7750	250 A	200 μΩ	13 W
FHR 2/4-10050	150 A	333 μΩ	8 W
FHR 2/4-6520	100 A	500 μΩ	5 W
FHR 2/4-10020	50 A	1000 μΩ	3 W

(other rated currents and nominal outputs upon request possible)

Tolerances	:	1%, 2%, 5% (other Tolerances upon request)
Temperature Coefficient	:	±15 ppm/K (20°C ... 60°C, only 4-pin type)
Thermal EMF	:	< 1 μV/K

ENVIRONMENTAL

Operating Temperature Range : -40°C ... 130°C

MECHANICAL

Resistor Material	:	Metalplate CuNiMn (DIN 17471)
Connector Material	:	Cu, upon request nickelized 2-pin, 4-pin

TEMPERATURE COEFFICIENT

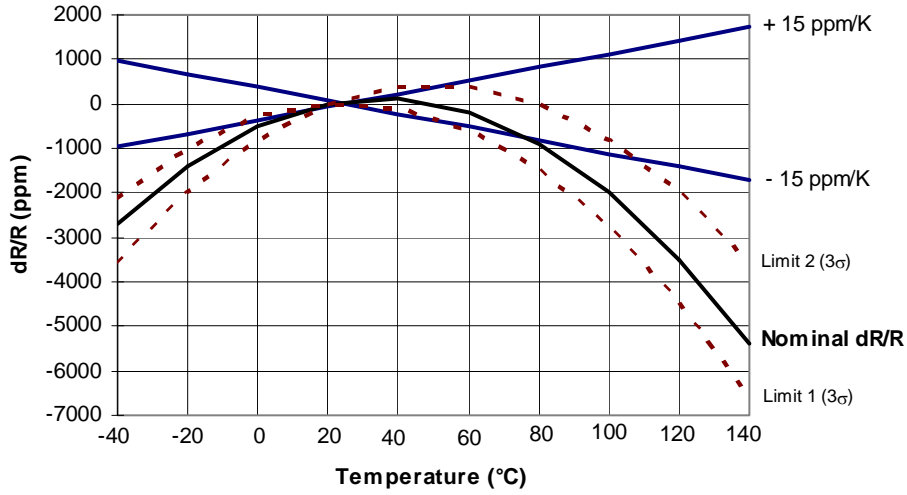

DERATING CURVE

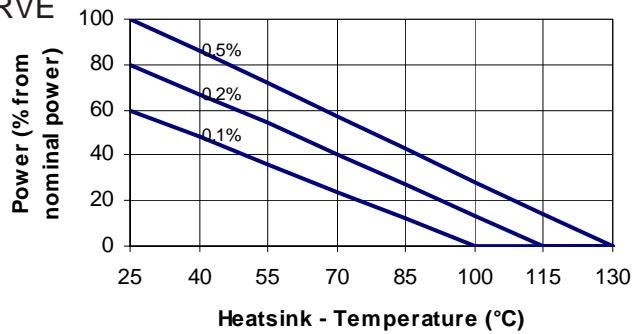

CONSTRUCTION

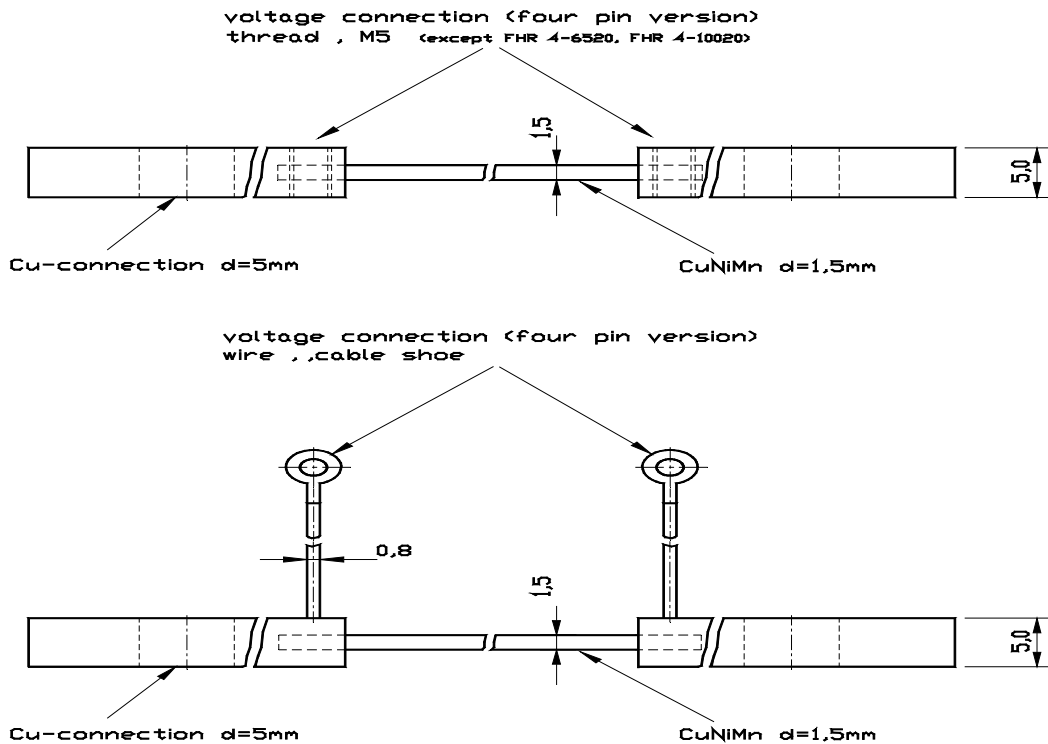

DIMENSIONS

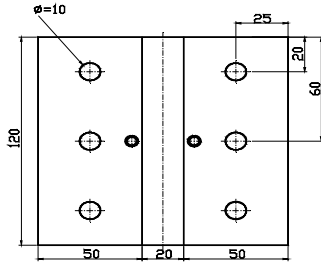

FHR2/4 - 120120

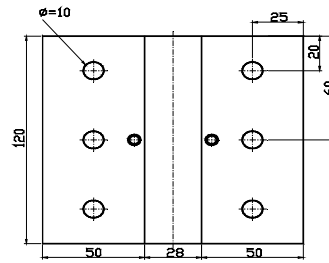

FHR2/4 - 128120

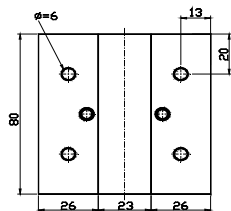

FHR2/4 - 7580

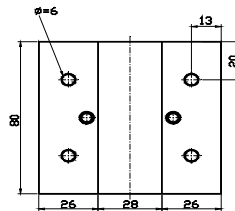

FHR2/4 - 8080

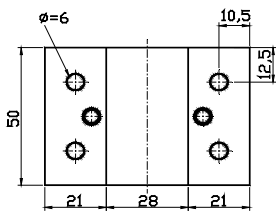

FHR2/4 - 7050

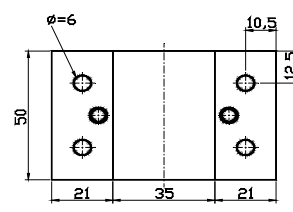

FHR2/4 - 7750

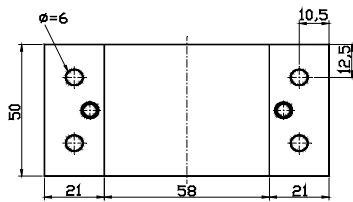

FHR2/4 - 10050

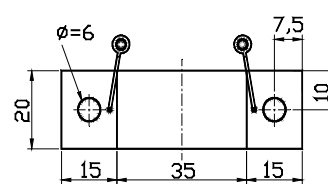

FHR2/4 - 6520

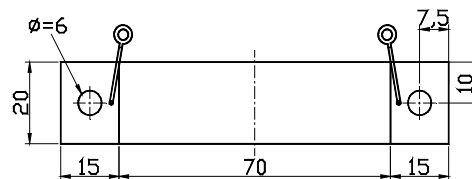

FHR2/4 - 10020

HOW TO ORDER

FHR 2-120120 0R00005 5%

FHR 4-8080 0R0001 2%

FHR 4-6520 0R0005 2%

III. PRECISION SHUNT NETWORKS

Precision-Networks

Type	Resistance Range	Power max.	Temperature Coefficient	Tolerance	Stability	Page
FPN FHN	0R01 ... 90R	30 Watt	$\pm 15\text{ppm/K}$	0.1%	0.1%	71
FPN 3-4916 FHN 3-5426 FHN 3-6819	0R01 ... 90R	20 Watt	$\pm 15\text{ppm/K}$	0.1%	0.1%	74
FPN 4-5716 FHN 4-6426 FHN 4-7819	0R01 ... 90R	20 Watt	$\pm 15\text{ppm/K}$	0.1%	0.1%	75
FPN 5-4818	0R01 ... 90R	2 Watt	$\pm 15\text{ppm/K}$	0.1%	0.1%	76
FPN 7-6516	0R025 ... 2R5	2 Watt	$\pm 15\text{ppm/K}$	0.1%	0.1%	77
FHN 4-8526 FHN 6-8526	0R01 ... 9R	30 Watt	$\pm 15\text{ppm/K}$	0.1%	0.1%	78



- Resistor Values over four Decades
- Extremely Low Ohm Rating
- Kelvin Connection
- Small Temperature Coefficient
- Low Inductance

SPECIFICATIONS

ELECTRICAL

	FPN	FHN 5426/6819 FHN 6426/7819	FHN 8526
--	-----	--------------------------------	----------

Resistance Range	:	R010...90R		
Power Rating	:	2 W (70°C)	2 W (70°C) from to 20W*	3 W (70°C) from to 30W*
		* with heatsink depending on the quantity of the single resistors		
Tolerances	:	0.1%, 0.25%, 0.5%, 1%		
Stability	:	0.1%, 0.2%, 0.5% (depends on stress)		
Temperature Coefficient	:	± 15 ppm/K (20 ... 60)°C		
Voltage Proof	:	-	>1 kV DC	>1 kV DC
Insolation Resistance	:	> 10 GOhm	-	-
Thermal EMF	:	< 1 µV/K		
Max. Current	:		25 A	25 A

ENVIRONMENTAL

Operating Temperature Range : -40°C...130°C

MECHANICAL

Resistor Material	:	Metalfoil CuNiMn (DIN 17471)
Substrate	:	anodized aluminium
Housing	:	Epoxy
Connector Material	:	Cu tinned
Max. torque backplate	:	1 Nm

TEMPERATURE COEFFICIENT

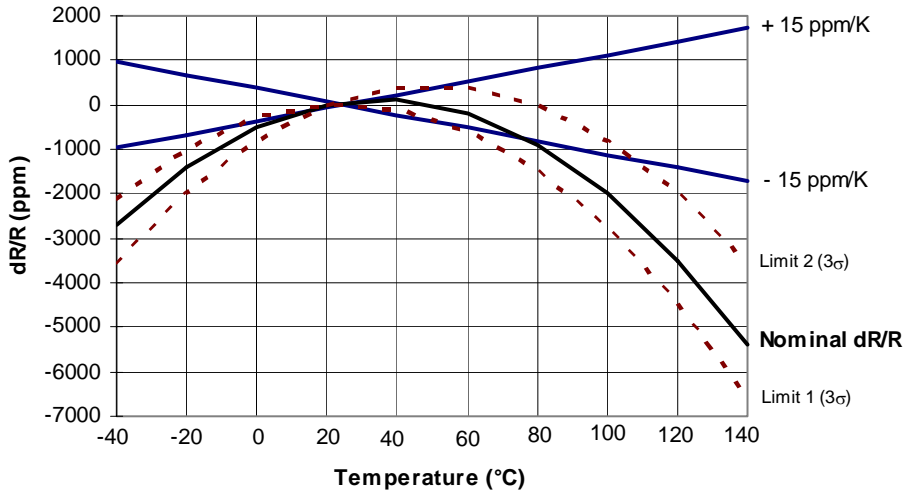

DERATING CURVE

FPN:

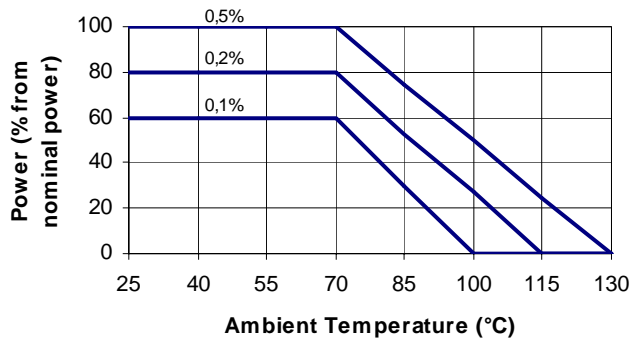

FHN:

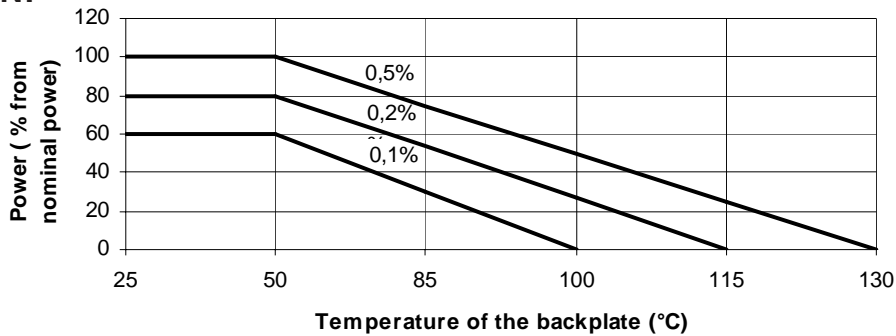

Pattern

The resistor networks can be configured upon request of the customer. The only restrict is the grid of 5.08mm between two contacts. The point of the contact can be in a grid dimension of 2.54mm.

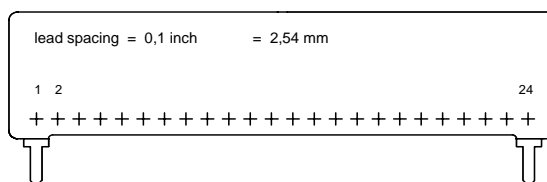

RESISTANCE VALUE COMBINATION

Description	Type	Resistance Value Combination
FPN 3-4916 / FHN 3-5426 / FHN 3-6819	A	R01 - R09 - R90
	B	R01 - R10 - R90
	C	R09 - R90 - 9R0
	D	R10 - R90 - 9R0
	E	R90 - 9R0 - 90R
	F	1R0 - 9R0 - 90R
	G	R10 - R90 - 9R0
FPN 4-5716 / FHN 4-6426 / FHN 4-7819	B	R01 - R09 - R90 - 9R0
	C	R10 - R90 - 9R0 - 90R
	D	R05 - R45 - 4R5 - 45R
	E	R025 - R075 - R150 - R250
FHN 4-8526	B	R01 - R09 - R90 - 9R0
FPN 5-4818	A	R01 - R09 - R90 - 9R0 - 90R
	R	R033 - R067 - R90 - 9R0 - 90R
FHN 6-8526	K	R025 - R075 - R15 - R75 - 1R5 - 7R5
FPN 7-6516	A	R025 - R075 - R15 - R25 - R50 - 1R5 - 2R5

(Detailed drawings and applications see the following pages.)

HOW TO ORDER

FPN 3-4916 A 0.1% R01-R09-R90
 FHN 3-5426 C 0.1% R09-R90-9R0
 FPN 4-5716 B 0.1% R010-R090-R900-9R00
 FHN 4-6426 C 0.5% R10-R90-9R0-90R
 FPN 5-4818 A 0.1% R010-R090-R900-9R00-90R0
 FHN 6-8525 K 1.0% R025-R075-R15-R75-1R5-7R5
 FPN 7-6516 A 0.1% R025-R075-R15-R25-R50-1R5-2R5

FPN3-4916 FHN3-5426 / 3-6819



APPLICATION NOTE

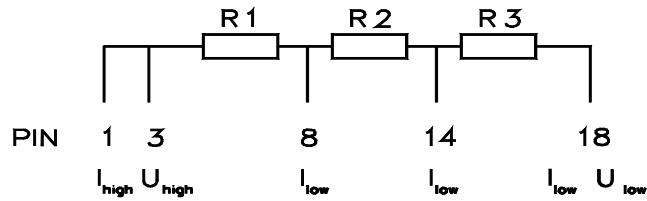

DIMENSIONS

FPN 3-4916

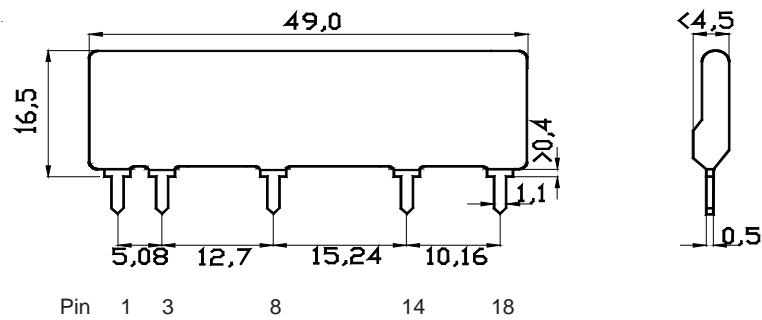

FHN 3-5426

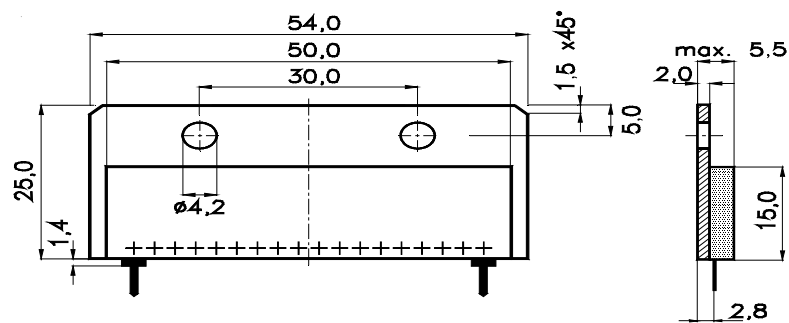

FHN 3-6819

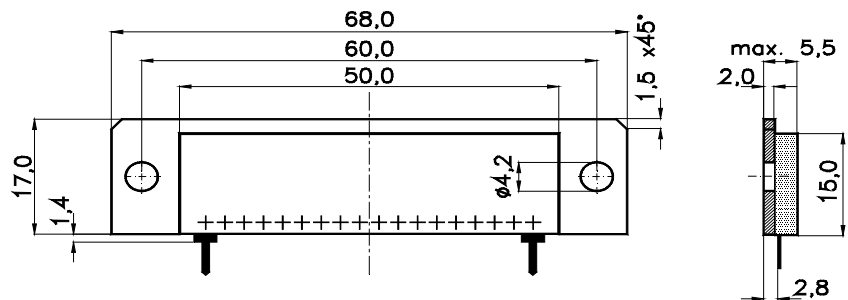

Dimensions in mm

FPN4-5716 FHN4-6426 / 4-7819



APPLICATION NOTE

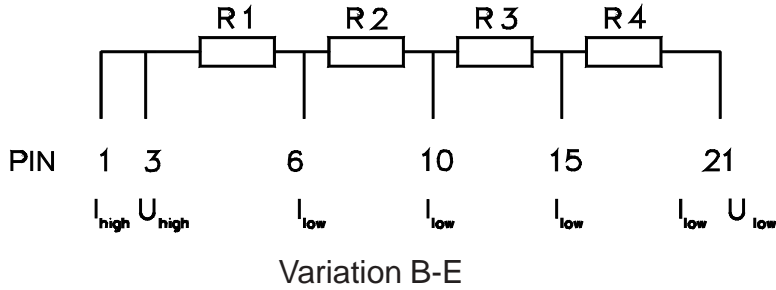

DIMENSIONS

FPN 4-5716

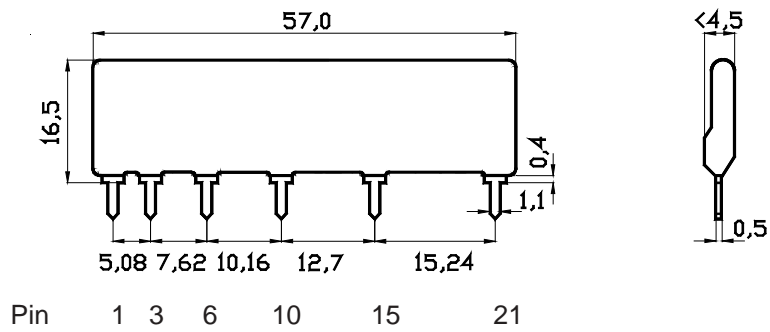

FHN 4-6426

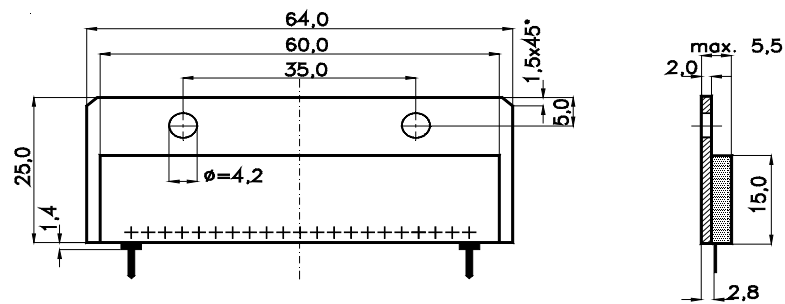

FHN 4-7819

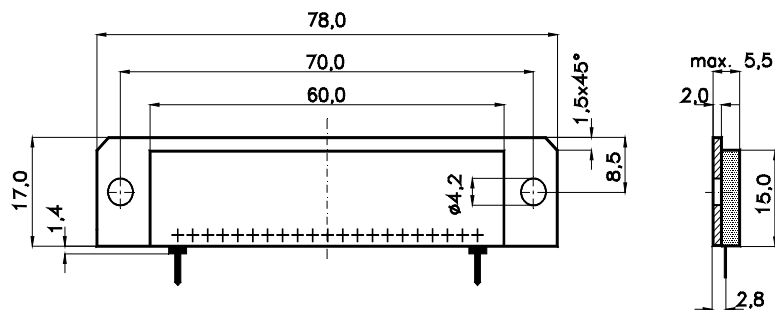

Dimensions in mm

APPLICATION NOTE

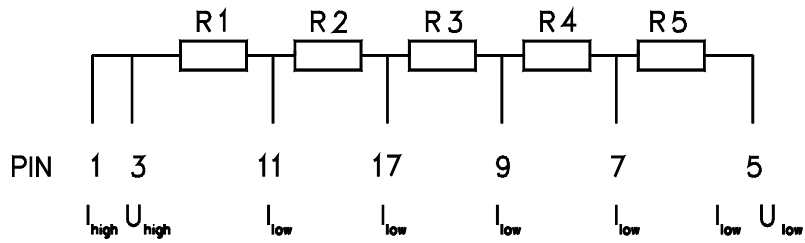

DIMENSIONS

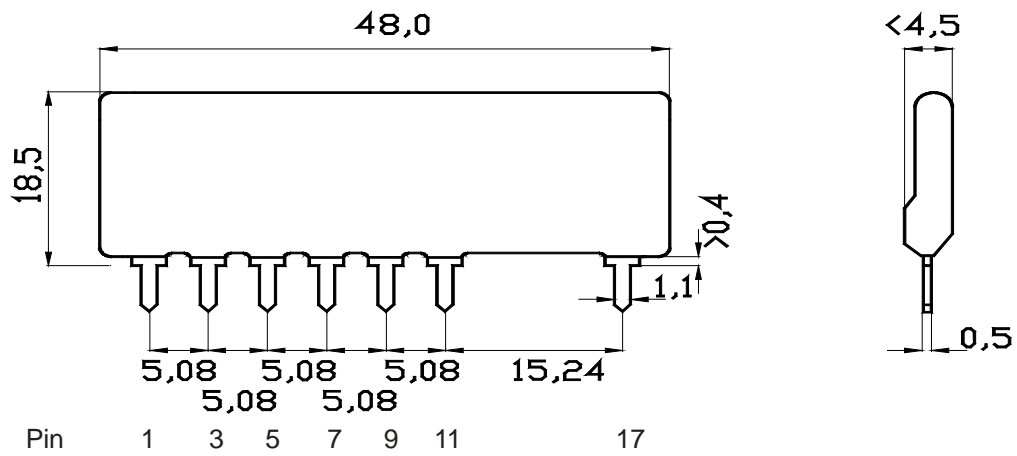

Dimensions in mm

FPN7-6516



APPLICATION NOTE

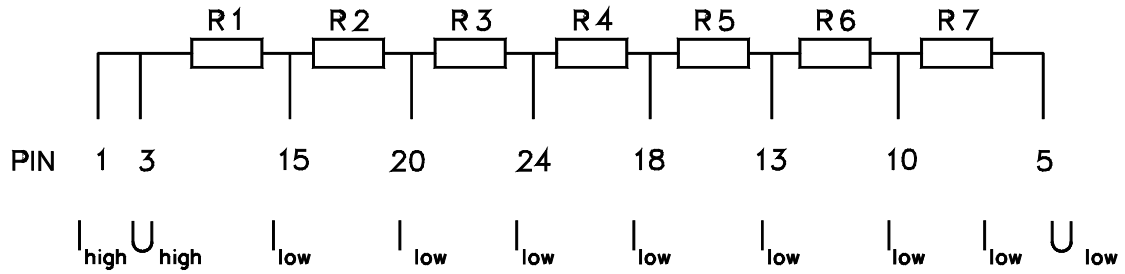

DIMENSIONS

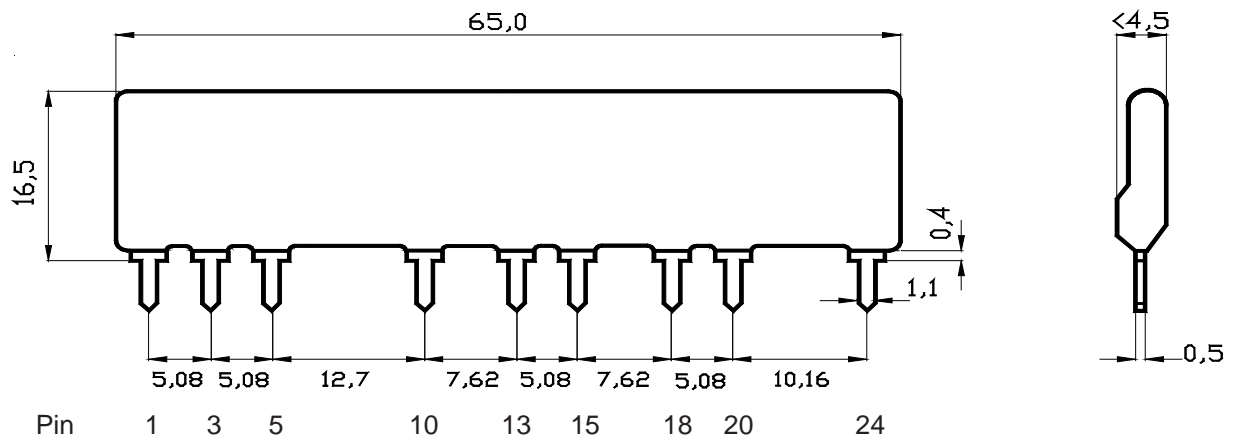

Dimensions in mm

FHN 4-8526 FHN 6-8526



APPLICATION NOTE

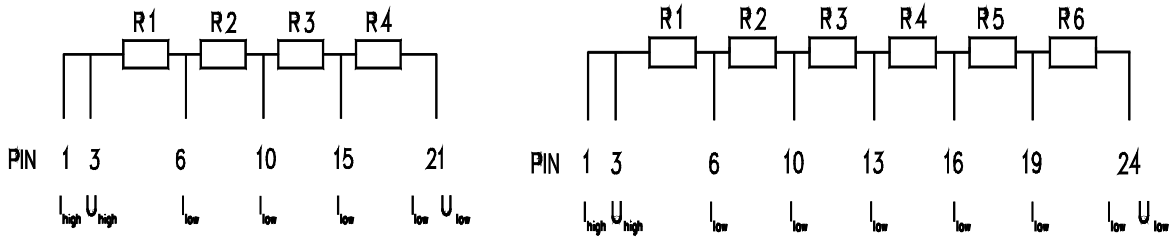

DIMENSIONS

FHN 4-8526

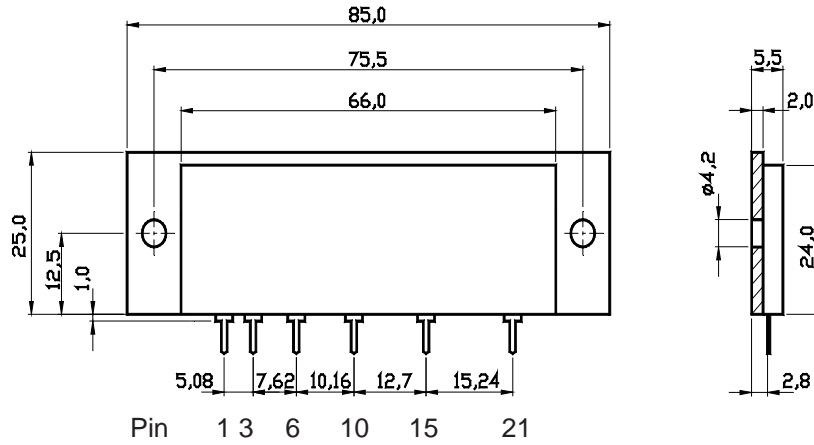

FHN 6-8526

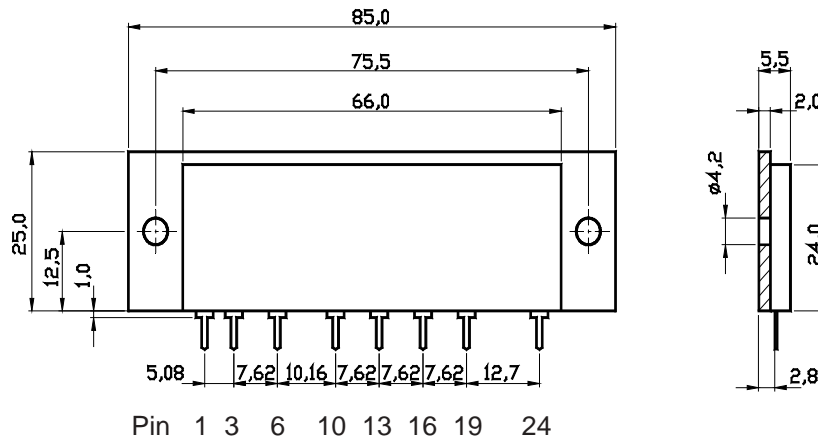

Dimensions in mm

IV. POWER-RESISTORS

Power-Resistors

Type	Resistance Range	Power max.	Temperature Coefficient	Tolerance	Stability	Page
FPR 2-T218	0R002 ... 50R	30 Watt	± 15ppm/K	0.1%	0.5%	81
FPR 2-T220, 4-T220 FPR 2-T220, 4-T221 FPS 2-T220, 4-T220	0R002 ... 50R	15 Watt	± 15ppm/K	0.1%	0.1%	83
FHR FNR 2-T238 FHR FNR 4-T238	0R001 ... 100R	80 Watt	± 15ppm/K	0.5%	0.5%	87
FPR FNR 2-T227, 4-T227	0R001 ... 100R	80 Watt	ab ± 15ppm/K	0,5%	0,1%	91
FHR 2-8065, 80110, 80216, 80320, 80370	0R001 ... 500R	2500 Watt	± 15ppm/K	0.5%	0.5%	95
KPR 2-T218	0R1 ... 100k	50 Watt	± 100ppm/K	1.0%	1.0%	101
KHR 2-T218	0R1...100k	100 W	typ. ±100ppm	1.0%	1.0%	103
NPR 2-T220 NPR 2-T221 NPS 2-T220	0R02 ... 100k	30 Watt	± 100ppm/K	1.0%	0.5%	105
NHR 2-T220/T221	0R02...15k	50 W	typ. ±100ppm	1.0%	0.5%	107
KPR KPN 2-T227 KPR KPN 4-T227 KHR KHN 2-T227 KHR KHN 4-T227	0R05 ... 1M	200 Watt	± 100ppm/K	1,0%	1,0%	109



- Extremely Low Ohm Rating
- High Stability
- Low Temperatur Coefficient
- Low Electrical Noise
- Low Inductance
- TO-Standard Housing

SPECIFICATIONS

ELECTRICAL

	FPR 2-T218
Resistance Range	: R002 ... 50R
Power Rating	: 2 W (70°C) 30 W with heatsink
Thermal Resistance Rthj-c	: 2.5 K/W
Tolerances	:
from R002	: 1%, 2%, 5%
from R010	: 0.5%, 1%, 2%, 5%
from R020	: 0.25%, 0.5%, 1%, 2%, 5%
from 1R0	: 0.1%, 0.25%, 0.5%, 1%, 2%, 5%
Stability	: 0.5%
Temperatur Coefficient	: ±15 ppm/K (20...60)°C / ±50 ppm/K (-40...130)°C R ≤ 0R2 TCR-Shift depends on resistor value see next page for detailed informations
Voltage Proof	: 300 VDC
Thermal EMF	: < 1 µV/K

ENVIRONMENTAL

Operative Temperature Range : -40°C...130°C

MECHANICAL

Resistor Material	:	Metalfoil CuNiMn (DIN 17471)
Substrate	:	anodized aluminium
Housing	:	PPS
Connector Material	:	Cu tinned, 2-pin
Max. Torque backplate	:	1 Nm

TEMPERATURE COEFFICIENT

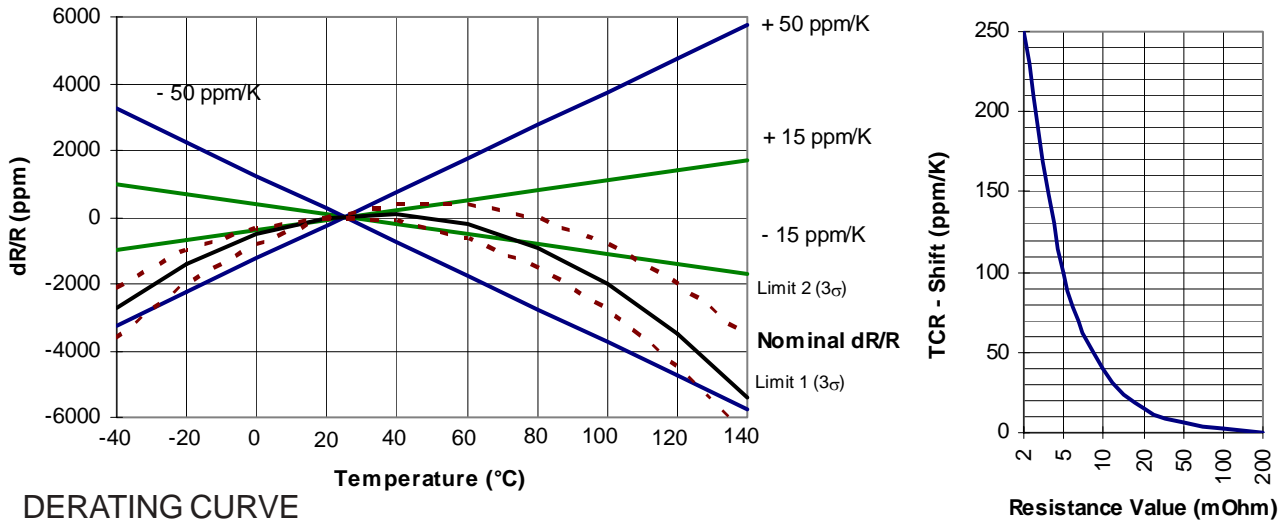

DERATING CURVE

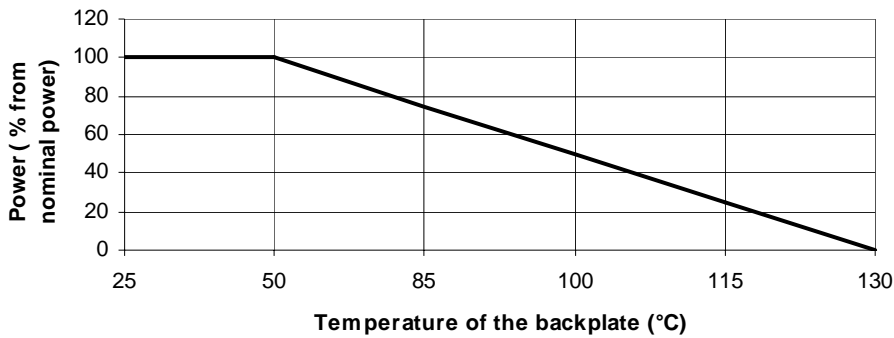

DIMENSIONS

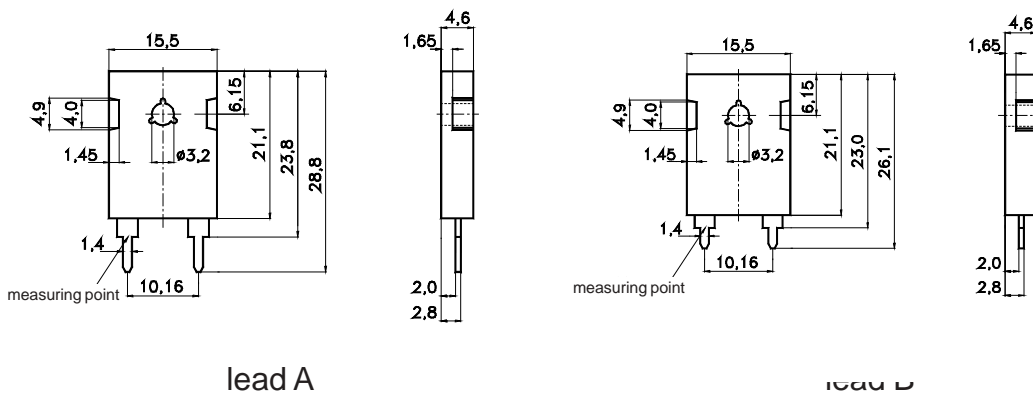

Standardlead for T-218 : lead B

Dimensions in mm

HOW TO ORDER

FPR 2-T218 10R B 0.5%
 FPR 2-T218 R068 B 0.5%

FPR 2-T218 10R0 B 1.0%
 FPR 2-T218 R068 A 0.5%

FPR / FPS

2-T220 4-T220 2-T221 4-T221



- Extremely Low-Ohm
- Small Dimensions
- High Stability
- Low Inductance
- Low Electrical Noise
- Low Temperature Coefficient
- TO220-Housing
- SMD available

SPECIFICATIONS

ELECTRICAL

Resistor Range	:	0R002 ... 50R
Power Rating	:	1.5 W (70°C) 15 W with heatsink
Thermal Resistance Rthj-c	:	4.8 K/W
Tolerances	:	
from 0R002	:	2%, 5% / 4-pin version also 1.0%
from 0R010	:	1%, 2%, 5%
from 0R100	:	4-pin version also 0.1% and 0.25%
	:	0.5%, 1%, 2%, 5%
	:	4-pin version also 0.1% and 0.25%
Stability	:	0.1%, 0.2%, 0.5% (depends on the stress)
Temperature Coefficient	:	±15 ppm/K (20...60)°C / ±50 ppm/K (-40...130)°C FPR 2-T220/221 R<0R2 TCR-Shift depends on resistor value (see table next page)
Max. Current	:	50 A
Insulation Resistance	:	300 VDC
Thermal EMF	:	< 1 µV/K

ENVIRONMENTAL

Operating Temperature	:	-40°C...130°C
------------------------------	---	---------------

MECHANICAL

Resistor Material	:	Metalfoil CuNiMn (DIN 17471)
Substrate	:	Al ₂ O ₃ or anodized aluminium
Housing	:	Epoxidharz or PPS
Connector Material	:	Cu tinned, 2-pin or 4-pin
Max. Torque backplate	:	1.0 Nm / T221: 0.8 Nm

TEMPERATURE COEFFICIENT

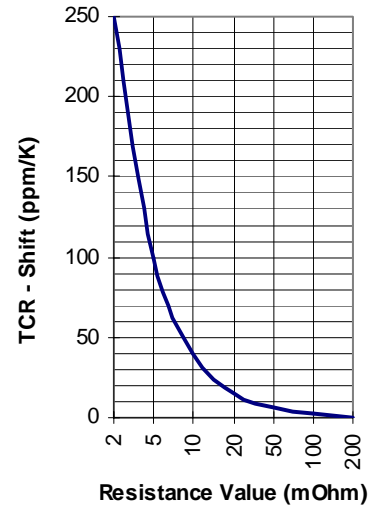
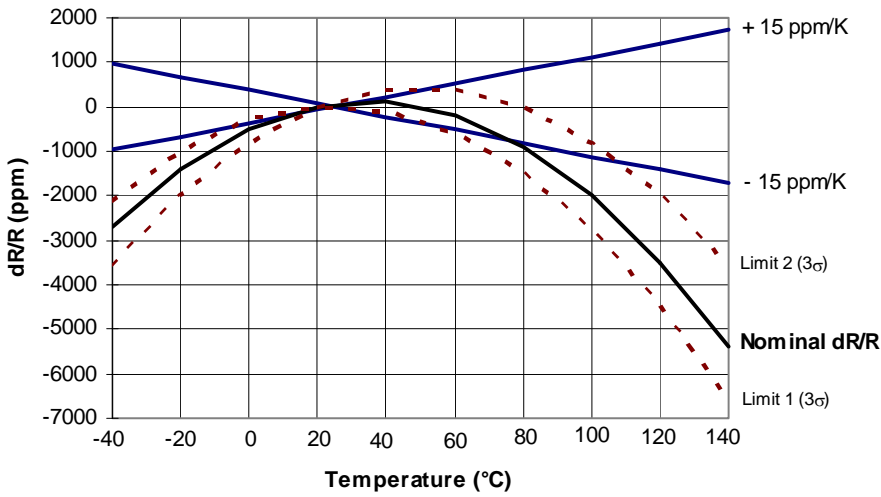

DERATING CURVE

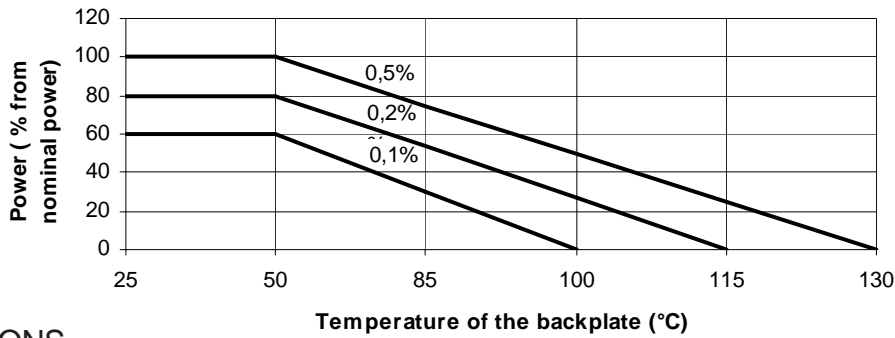

DIMENSIONS

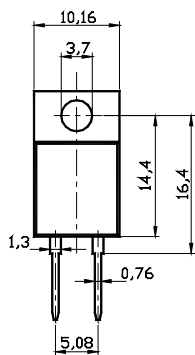

FPR 2-T220

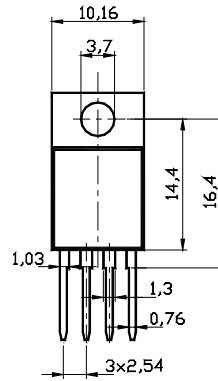
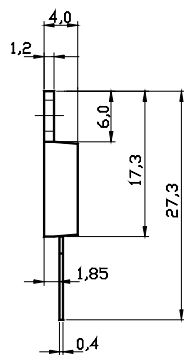

FPR 4-T220

DIMENSIONS

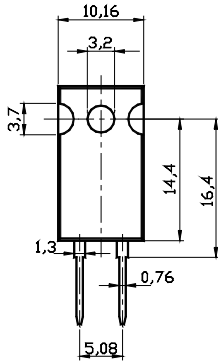

FPR 2-T221

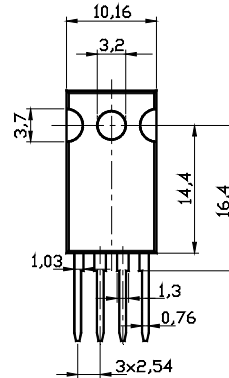
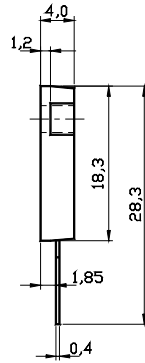

FPR 4-T221

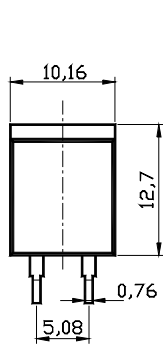
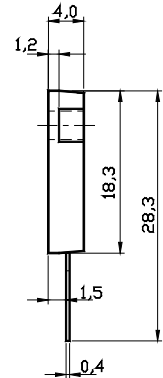

FPS 2-T220

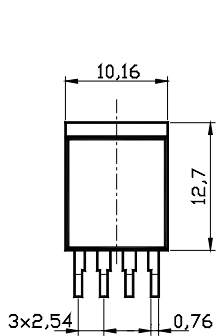
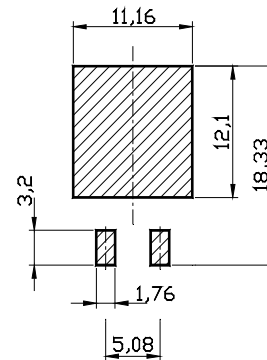
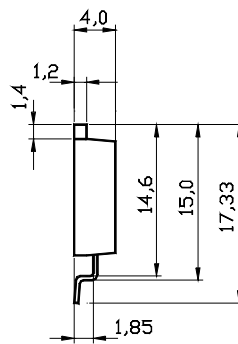

FPS 4-T220

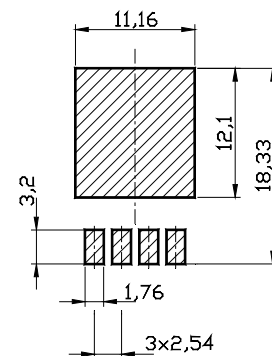
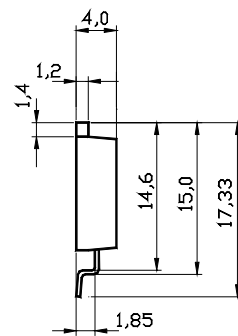

HOW TO ORDER

FPR 2-T220 10R 0.25%
 FPR 2-T221 0R068 0.5%

FPS 2-T220 1R0 1%
 FPR 4-T221 0R1 0.5%

FHR FNR 2-T238 4-T238



- Extremely Low Ohm Rating
- High Stability
- Two- and Four Circuit Technology
- Low Temperatur Coefficient
- Low Electrical Noise
- Low Inductance

SPECIFICATIONS

ELECTRICAL

	FHR 2/4-T238 FHN 2-T238	FNR 2/4-T238 FNN 2-T238
Resistance Range	: R01/R001...100R	R01/R001...100R
Power Rating	: 60 W* * with heatsink	80 W*
Thermal Resistance Rthj-c	: 1.3 K/W	1.0 K/W
Tolerances	: 0.5%, 1%, 2%, 5% (other Tolerances upon request)	
Stability	: 0.5	
Temperatur Coefficient	: ±15 ppm/K (20...60)°C / ±50 ppm/K (-40...130)°C R < R02: ±20 ppm/K (20...60)°C FHR/FNR2-T238 as well as FHN/FNN TCR-Shift depending on the resistor value	
Voltage Proof	: 2.5 kVDC	
Thermal EMF	: < 1 µV/K	
Max. Current	: 40 A (higher Values upon request)	45 A

ENVIRONMENTAL

Operative Temperature Range : -40°C...130°C

MECHANICAL

Resistor Material	: Metalfoil CuNiMn (DIN 17471)
Substrate	: Al ₂ O ₃ AIN
Housing	: Epoxy
Connector Material	: Cu or brass, tinned 2-pin, 4-pin

TEMPERATURE COEFFICIENT

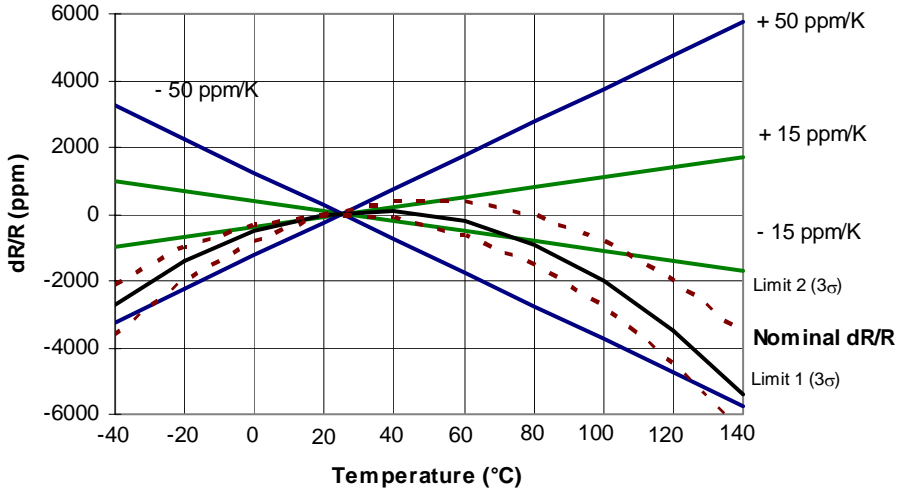

(FHR/FNR and FHN/FNN 2-T238)

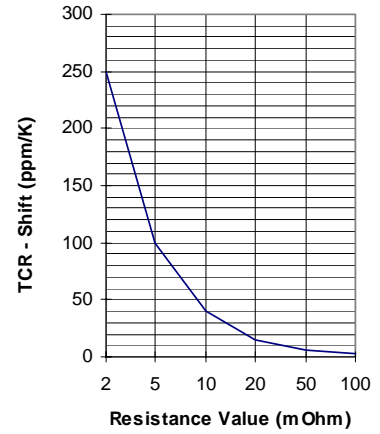

DERATING CURVE

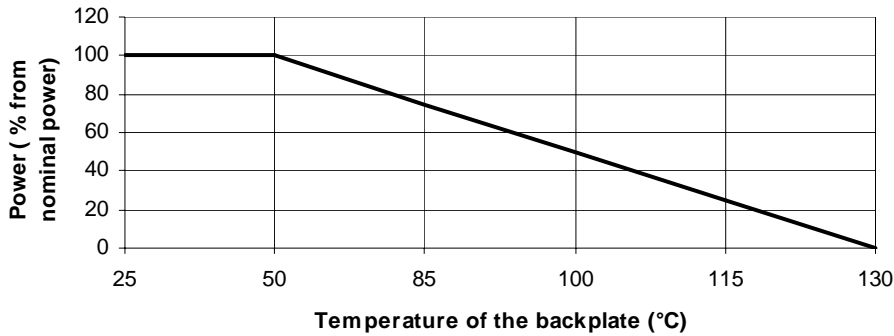

DIMENSIONS

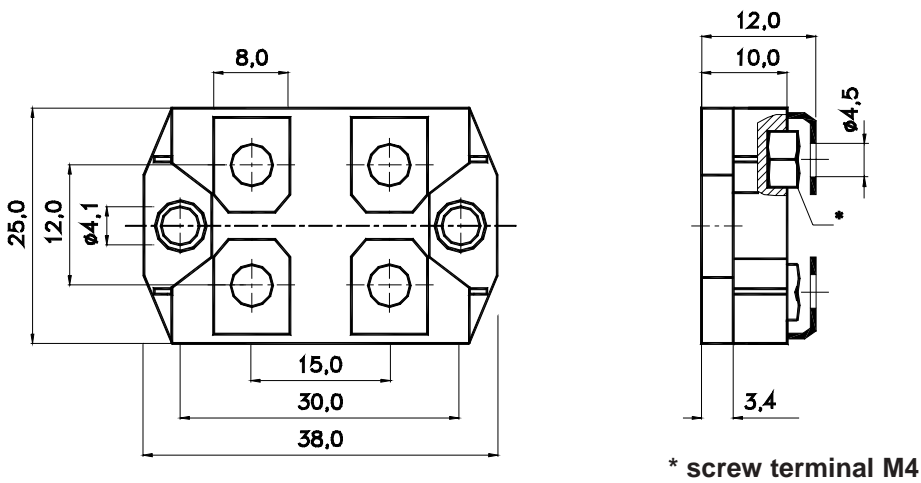

* screw terminal M4

Standard: Pin G (width= 6.35) leads curved

Dimensions in mm

FAULTY CONNECTION VARIATIONS

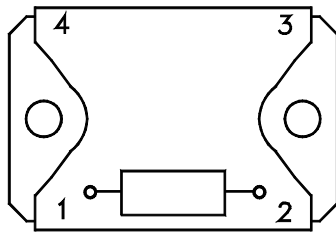

FHR/FNR 2-T238

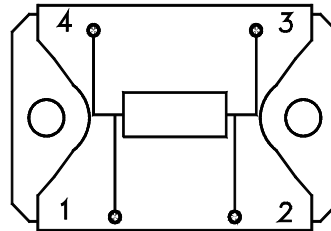

FHR/FNR 4-T238
1 - U1 / 2 - U2 / 3 - I2 / 4 - I1

Dimensions in mm

HOW TO ORDER

FHR 2-T238 1R1 G 1%

FNR 4-T238 R001 F 2%

FPR FNR 2-T227 4-T227



- Extremely Low-Ohm
- High Stability
- Two And Four Circuit Technology
- Low Temperature Coefficient
- Low Electrical Noise
- Low Inductance

SPECIFICATIONS

ELECTRICAL

	FPR 2/4-T227	FNR 2/4-T227
Resistance Range	: R01/R001 ...100R	R01/R001 ...100R
Power Rating	: 60 W * * with heatsink	80 W *
Thermal Resistance Rthj-c	: 1.3 K/W	1.0 K/W
Tolerances	: 0.5%, 1%, 2%, 5% (others upon request)	
Stability	: 0.1%, 0.2%, 0.5 (depends on stress)	
Temperature Coefficient	: ±15 ppm/K (20...60)°C from R < R02 ±20 ppm/K (20...60)°C FPR/FNR 2-T238 TK-Shift depends from resistance value (see next page)	
Voltage Proof	: 2.5 kV DC	
Thermal EMF	: < 1 µV/K	
Max. Current	: 50 A (higher upon request)	50 A

ENVIRONMENTAL

Operating Temperature Range : -40°C...130°C

MECHANICAL

Resistor Material	: Metalfoil CuNiMn (DIN 17471)
Substrate	: Al ₂ O ₃ AIN
Housing	: Epoxidharz
Connector Material	: Cu, tinned, 2-pol / 4-pol
Max. Torque	: backplate: 1.5 Nm terminals: 1.3 Nm

TEMPERATURE COEFFICIENT

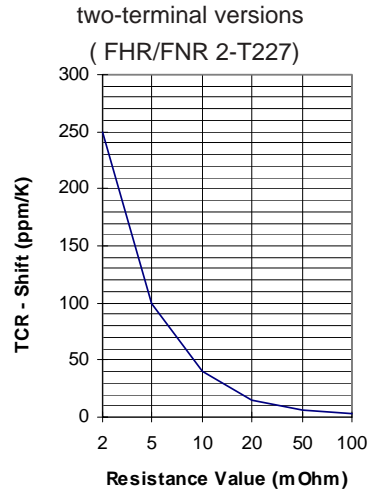
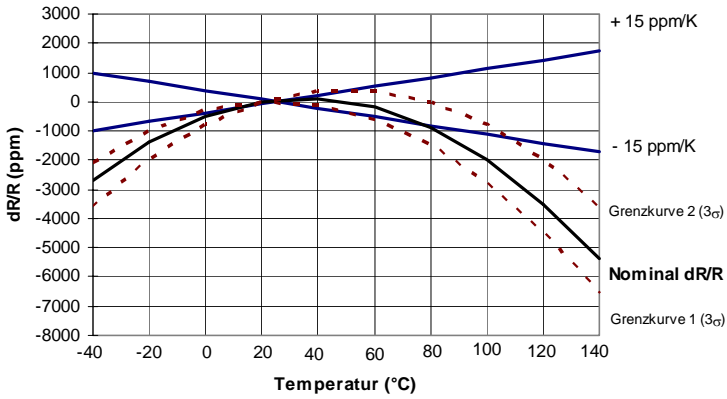

DERATING CURVE

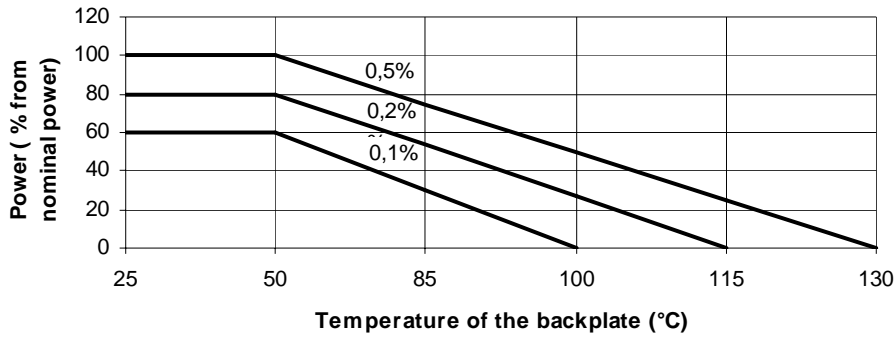

DIMENSIONS

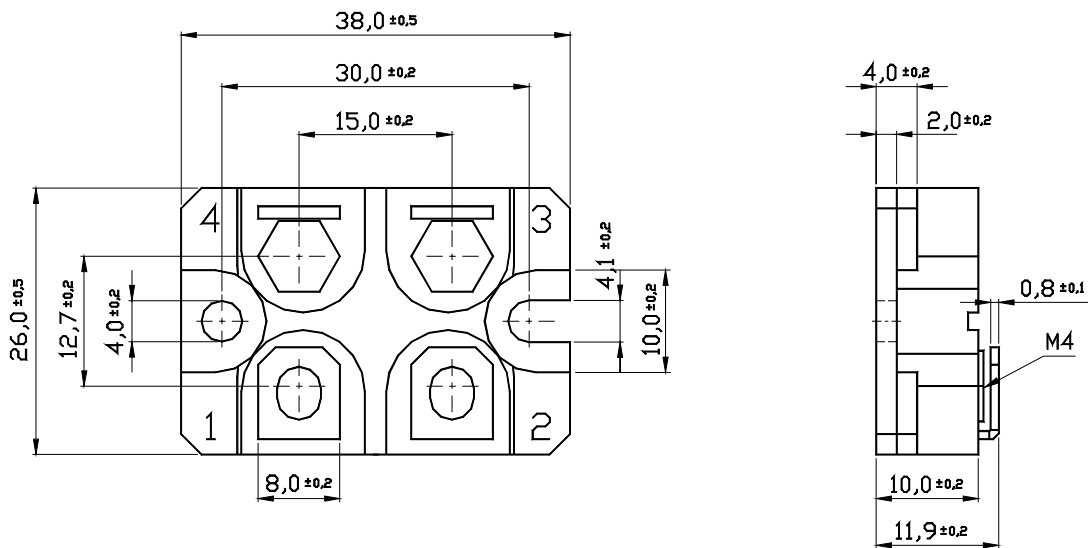

Standardkontakt: G

Dimensions in mm

ATTACHMENT VARIATIONS

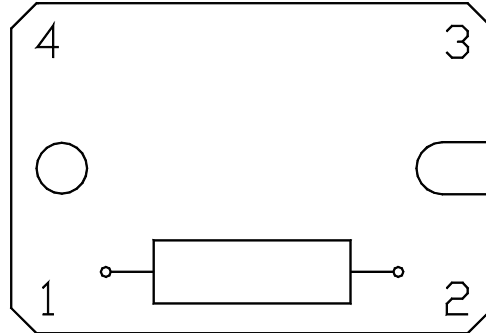

FPR 2-T227 / FNR 2-T227

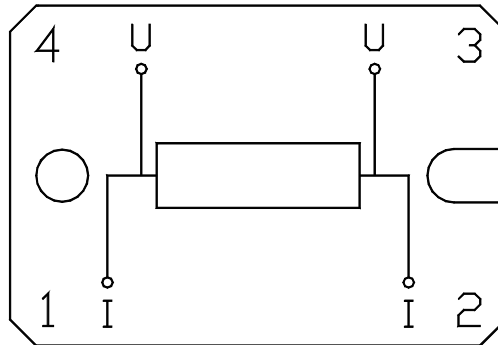

FPR 4-T227 / FNR 4-T227

HOW TO ORDER

FPR 2-T227 1R1 G 1%

FNR 4-T227 R001 G 2%

**FHR 2-8065 2-80110 2-80216
2-80320 2-80370**



- **Power Rating from to 2500 W**
- **High Stability**
- **Low Temperatur Coefficient**
- **Low Inductance**
- **Low Electrical Noise**

SPECIFICATIONS

ELECTRICAL

FHR 2-8065 / 80110 / 80216 / 80320 / 80370

Resistance Range	:	R001...500R (FHR 2-8065 up to 400R)
Power Rating	:	350 W / 600 W / 1200 W / 2000 W / 2500 W with heatsink 24 W / 32 W / 60 W / 80 W / 90 W without heatsink (25°C)
Thermal Resistance Rthj-c	:	0.16 / 0.09 / 0.04 / 0.026 / 0.022 K/W
Tolerances	:	0.5%, 1%, 2%, 5%, 10% (others upon request)
Stability	:	0.5%
Temperatur Coefficient	:	±15 ppm/K (20...60)°C / ±50 ppm/K (-40...130)°C R < 0R2: TCR-Shift depending on the resistor value (see next page)
Inductivity	:	< 50 nH
Capacity (against housing)	:	500 pF / 850 pF / 1.7 nF / 2.5 nF / 2.9 nF
Voltage Proof	:	1.5 kVDC (higher upon request)
Thermal EMF :	:	< 1 µV/K
Max. Current	:	60 A with Standardcontacts (with special contacts from to 250A upon request)

ENVIRONMENTAL

Operative Temperature Range : -40°C ... 130°C

MECHANICAL

Resistor Material	:	Metalfoil CuNiMn (DIN 17471)
Substrate	:	Aluminium
Housing	:	Aluminium
Connector Material	:	Cu Cable, 4mm², 500mm lenght (Other cables and connections upon request, AWG - cables are possible) 2-pin (4-pin upon request)

TEMPERATURE COEFFICIENT

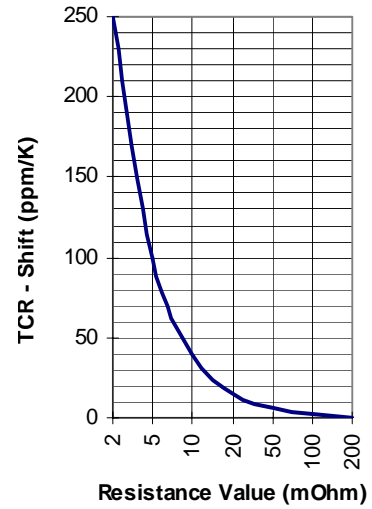
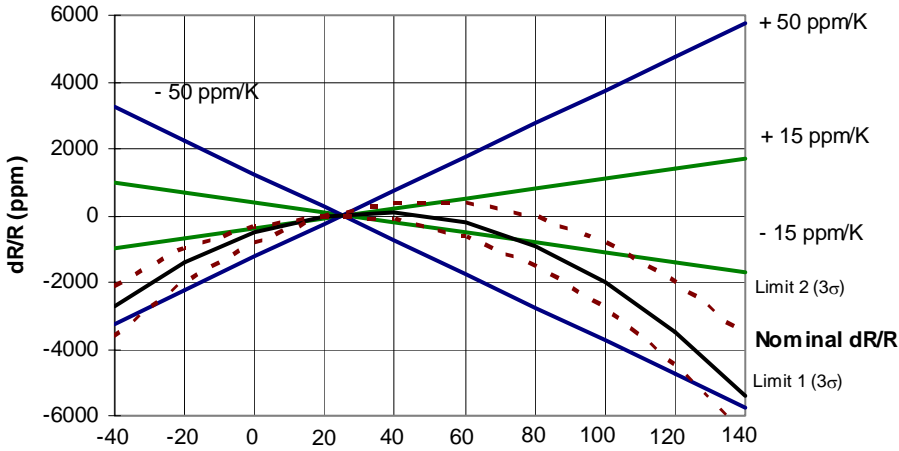

DERATING CURVE

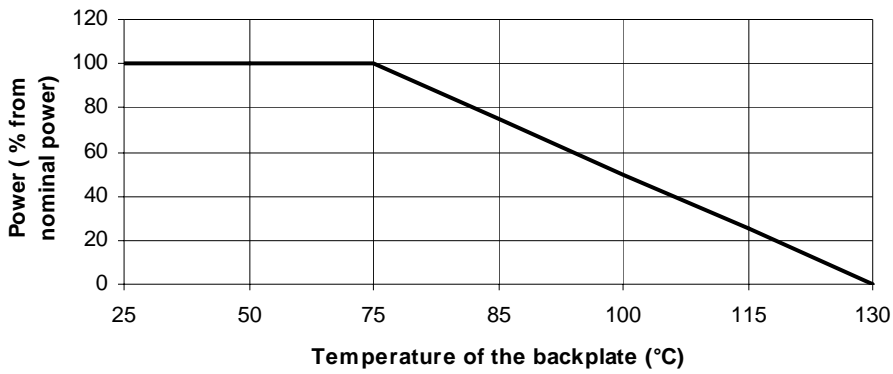

DIMENSIONS

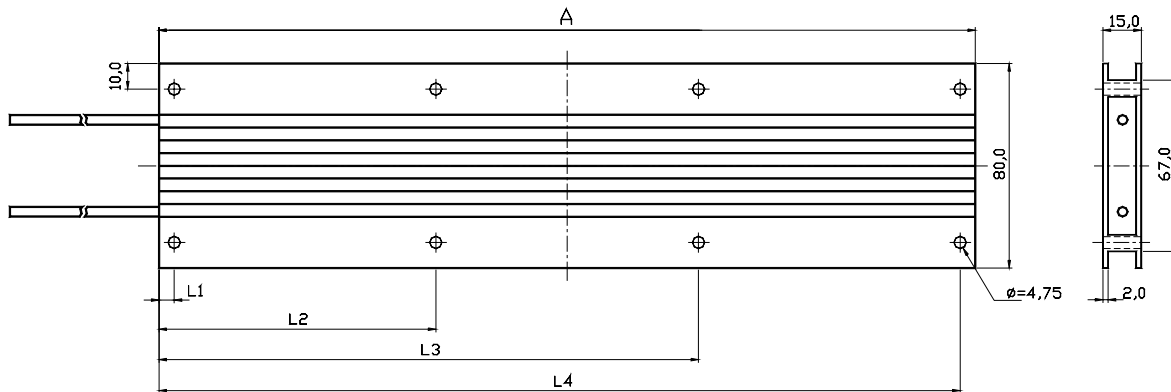

	A	L1	L2	L3	L4
FHR 4-8065	65	6,0	59,0		
FHR 4-80110	110	6,0	104,0		
FHR 4-80216	216	6,0	108,0	210,0	
FHR 4-80320	320	6,0	108,5	211,5	314,0
FHR 4-80370	370	6,0	125,5	244,5	364,0

Dimensions in mm

STABILITY AGAINST IMPULSES

Reference values without additional heatsink.

Resistor Value: 100R ... 500R

Impuls Energy

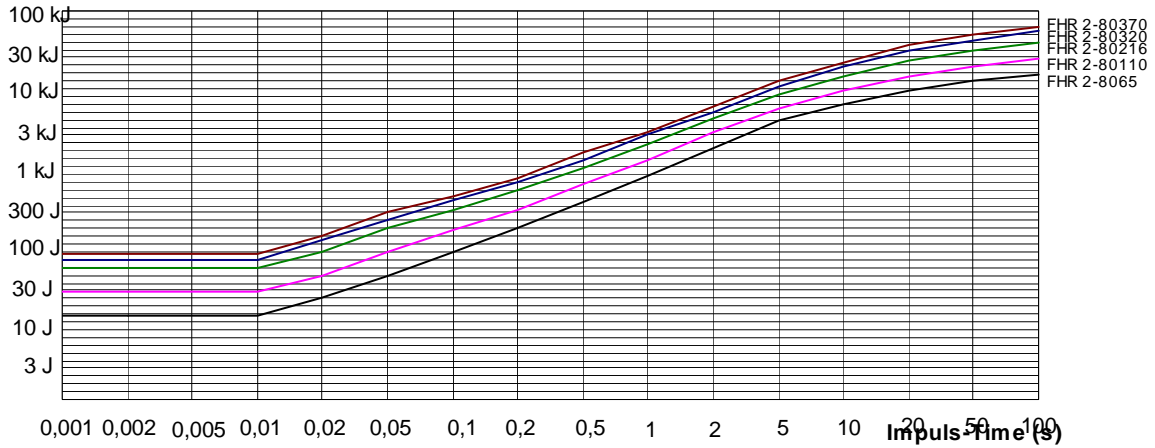

Resistor Value: 10R ... 100R

Impuls Energy

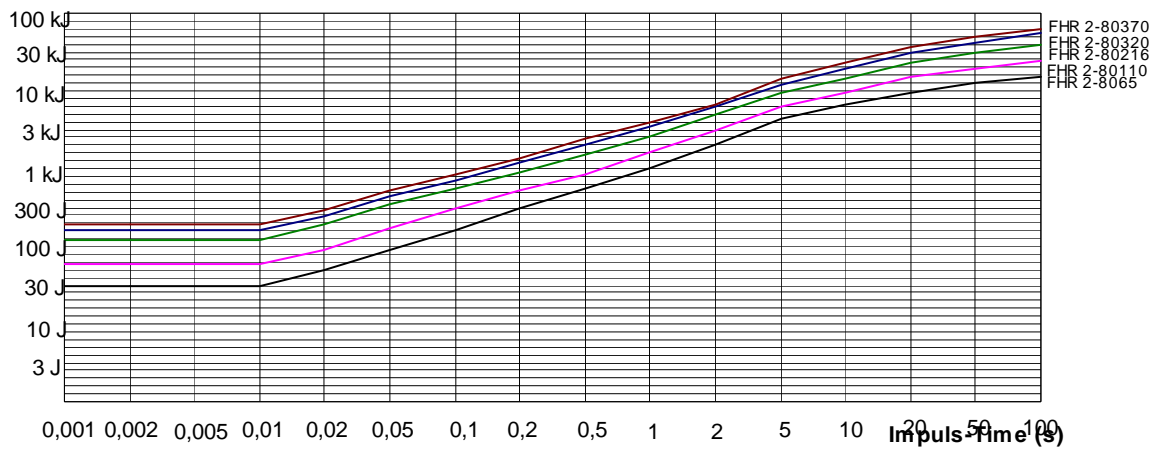

Resistor Value: 1R ... 10R

Impuls Energy

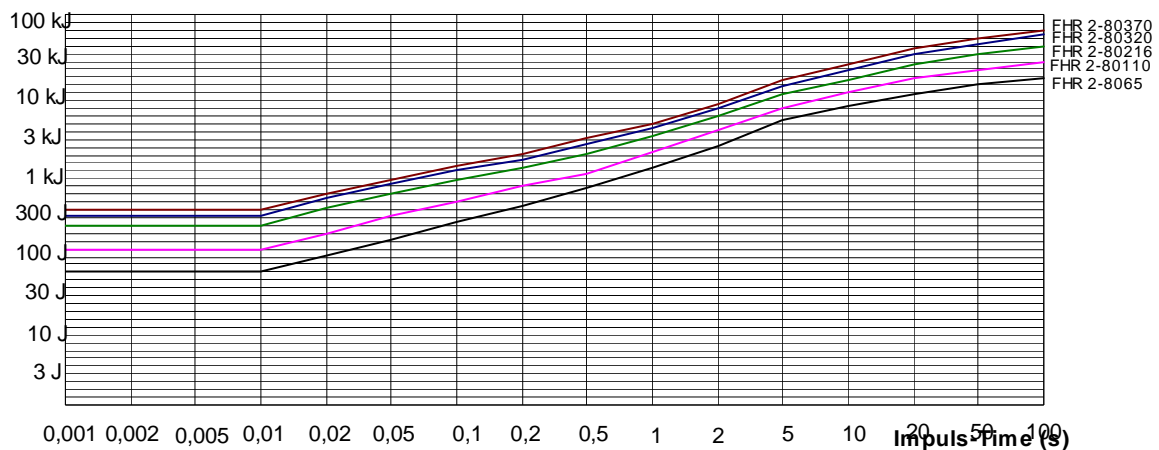

Resistor Value: R1 ... 1R

Impuls Energy

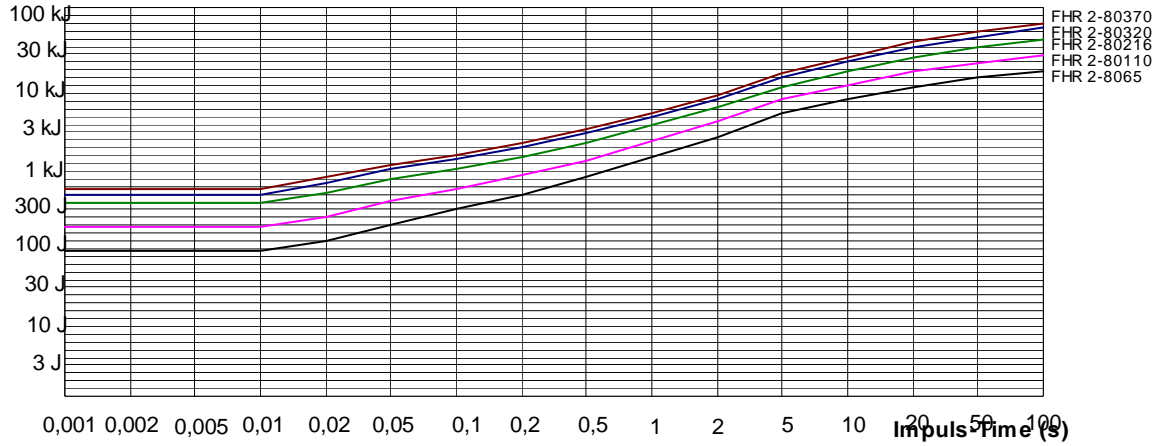

Resistor Value: R01 ... R1

Impuls Energy

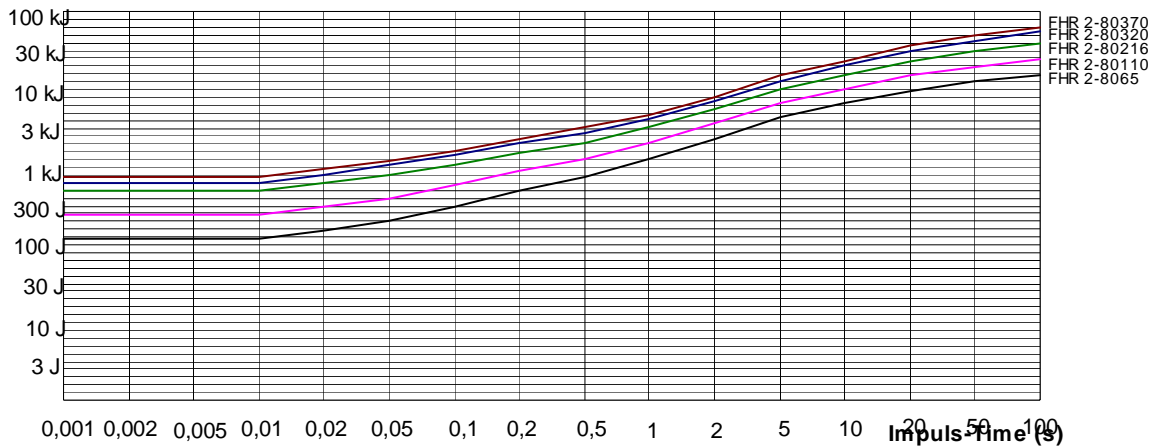

Resistor Value: R005 ... R01

Impuls Energy

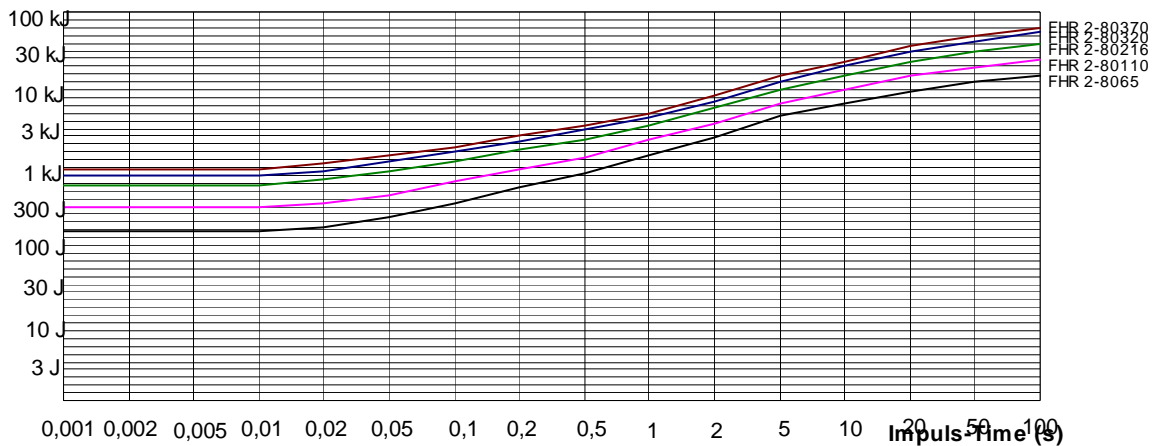

Resistor Value: R002 ... R005

Impuls Energy

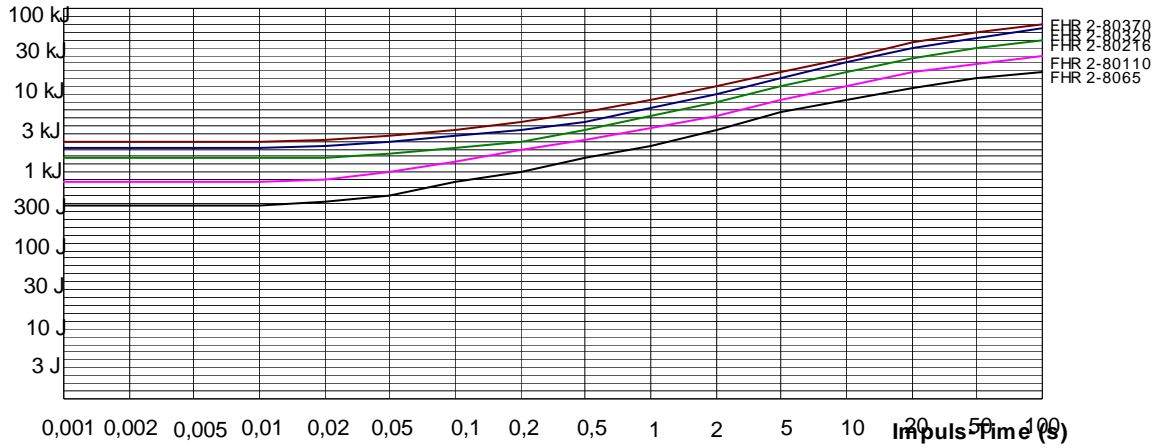

Resistor Value: R001 ... R002

Impuls Energy

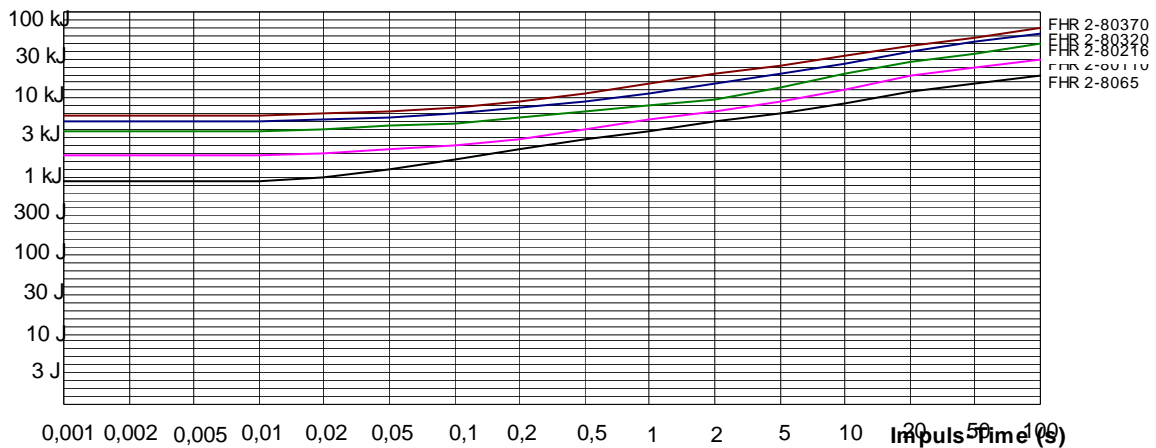

LEADS

Standard:	Lead D	from to 60 A isolated round cable (Cu, tinned)
optional:	Lead H1	from to 70 A isolated Cu - flat cable
	Lead H2	from to 85 A isolated Cu - flat cable
	Lead H3	from to 100 A isolated Cu - flat cable
	Lead H4	from to 120 A isolated Cu - flat cable
	Lead H5	from to 150 A isolated Cu - flat cable
	Lead H6	from to 250 A isolated Cu - flat cable

HOW TO ORDER

FHR 2-8065 1R0 D 1%
FHR 2-80370 2R0 D 2%

FHR 2-80216 10R D 1%
FHR 2-80370 0R05 H2 5%

KPR 2-T218



- Thick Film Resistor
- Power Rating from to 50 W
- For High Impulses
- Very Good as Heatingelement

SPECIFICATIONS

ELECTRICAL

Resistance Range	:	0R1 ... 100k
Power Rating	:	2 W (70°C) 50 W with heatsink
Thermal Resistance Rthj-c	:	2.1 K/W
Tolerances	:	
from 0R1		5%
from 1R0		2%
from 5R0		1%
Stability	:	1%
Temperatur Coefficient	:	±100 ppm/K

Max. Voltage

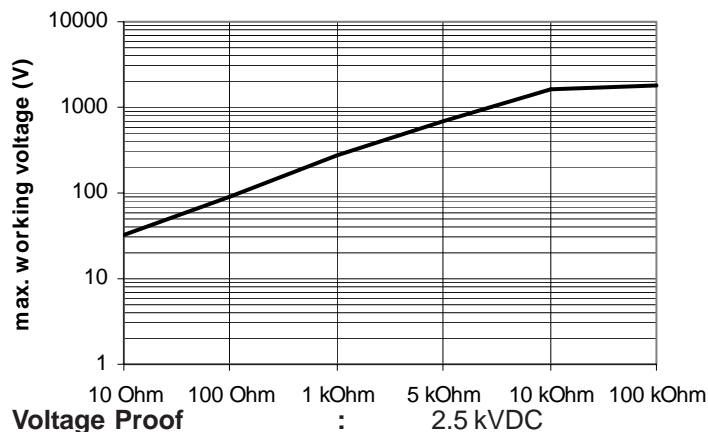

ENVIRONMENTAL

Operative Temperature Range	:	-55°C ... 155°C
-----------------------------	---	-----------------

MECHANICAL

Resistor Material	:	Thick Film
Substrate	:	Al ₂ O ₃ (upon request: AlN)
Housing	:	PPS
Connector Material	:	Cu tinned, 2-pin
Max Torque backplate	:	1 Nm

TEMPERATURE COEFFICIENT

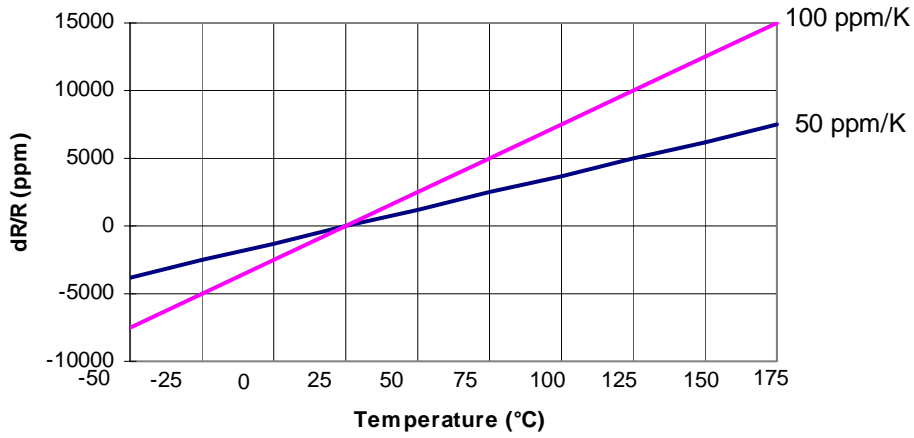

DERATING CURVE

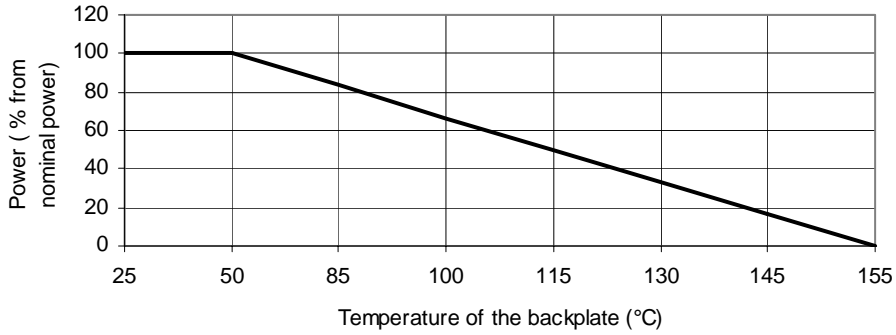

DIMENSIONS

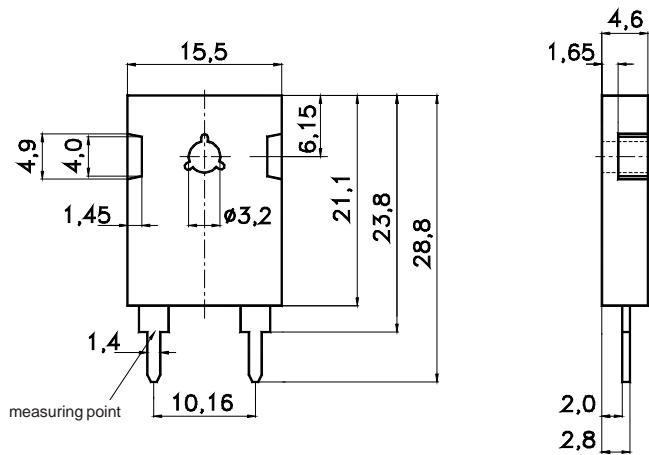

Dimensions in mm

HOW TO ORDER
KPR 2-T218 10K A 5%

KHR 2-T218



- Thickfilm Resistor
- Up to 100 W Power Rating
- For High Impulses

SPECIFICATIONS

ELECTRICAL

Resistance Range	:	0R1 ... 100k
Power Rating	:	2 W (70°C) 100 W with heatsink
Thermal Resistance Rthj-c	:	0.8 K/W
Tolerances	:	
from 0R1		5%
from 1R0		2%
from 5R0		1%
Stability	:	1%
Temperature Coefficient	:	±100 ppm/K

Max. Voltage

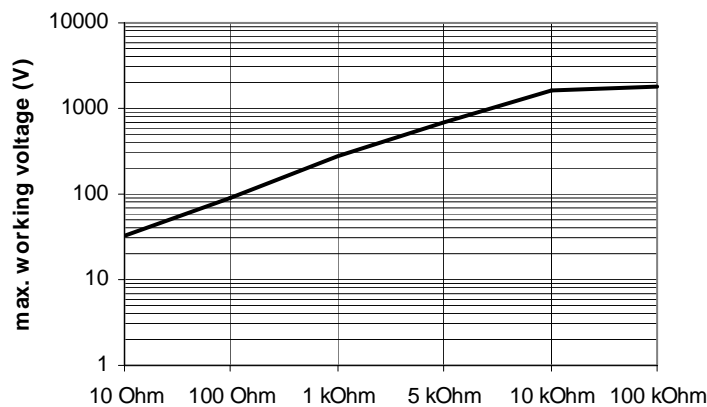

Voltage Proof	:	1.5 kVDC
----------------------	---	----------

ENVIRONMENTAL

Operating Temperature Range	:	-55°C ... 155°C
------------------------------------	---	-----------------

MECHANICAL

Resistor Material	:	Thickfilm
Substrate	:	Al ₂ O ₃ (upon request AlN)
Housing	:	PPS
Connector Material	:	Cu tinned, 2-pin
Max. Torque backplate	:	1 Nm

TEMPERATURE COEFFICIENT

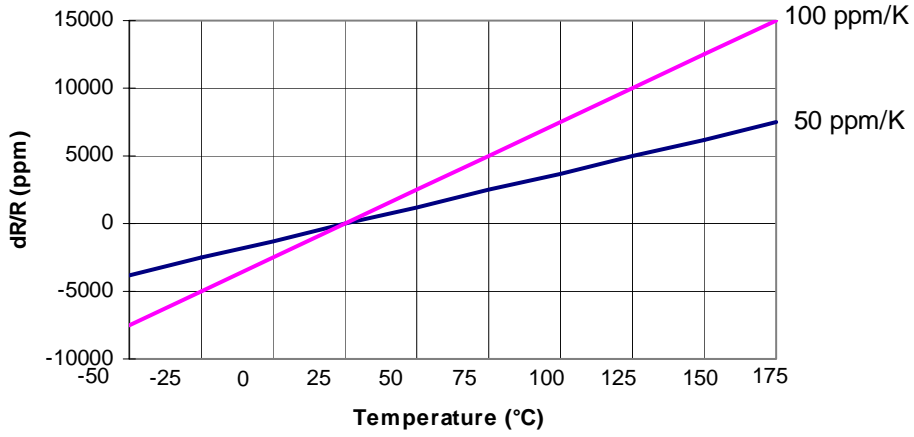

DERATING CURVE

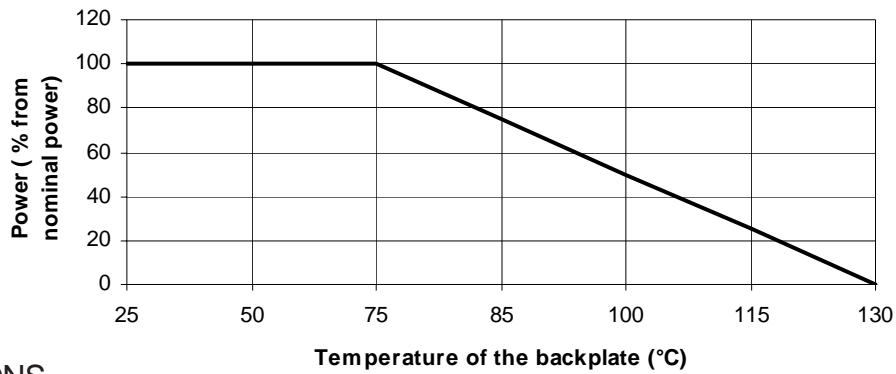

DIMENSIONS

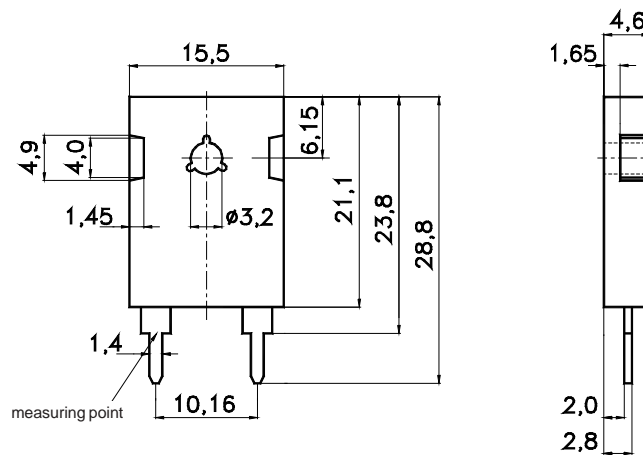

Standardlead: **Lead A**

Dimensions in mm

HOW TO ORDER

KHR 2-T218 15K A 5%

NPR 2-T220/T221 NPS 2-T220

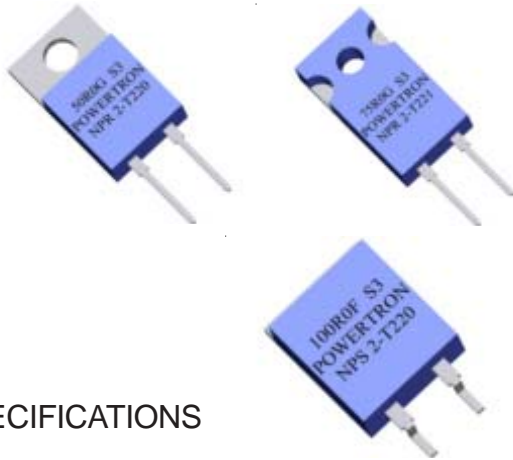

- High Power Rating
- Small Dimensions
- Easy to use
- Low Inductance
- TO220-Housing
- SMD Version available

SPECIFICATIONS

ELECTRICAL

Resistor Range	:	0R02 ... 100K
Power Rating	:	1.5 W (70°C) 30 W with heatsink
Tolerances	:	
from 0R02	:	2%, 5%
from 1R0	:	1%, 2%, 5%
Thermal Resistance Rthj-c	:	3.5 K/W
Stability	:	0.5%
Temperatur Coefficient	:	
0R02...0R049	:	±600 ppm/K
0R05...0R099	:	±300 ppm/K
0R1...100K	:	±100 ppm/K ±50 ppm/K upon request
Voltage Proof	:	2.0 kVDC

Max. Voltage

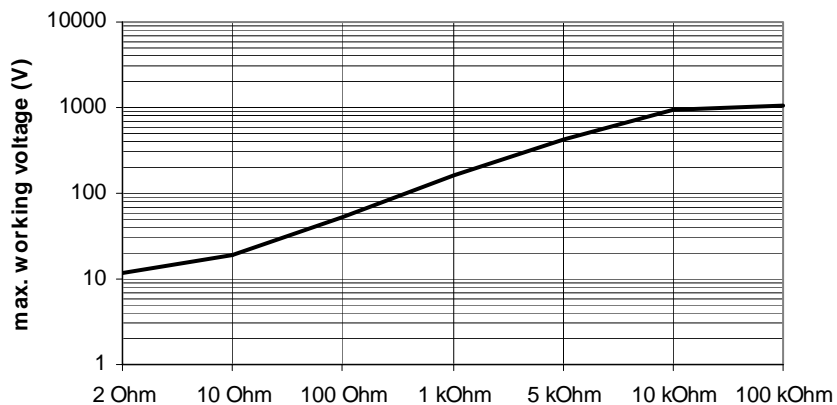

ENVIRONMENTAL

Operating Temperature Range : -40°C...155°C

MECHANICAL

Resistor Material	:	Thick Film
Substrate	:	Al ₂ O ₃
Housing	:	Epoxy or PPS
Connector Material	:	Cu tinned
Max. Torque backplate	:	1 Nm / T221: 0.8 Nm

NPR 2-T220/T221 NPS 2-T220



DERATING CURVE

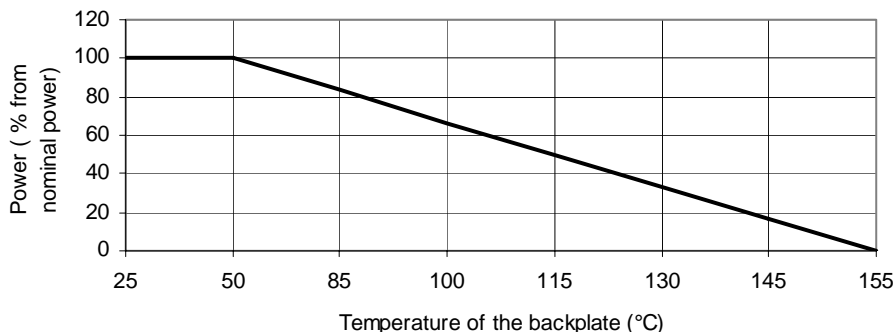

DIMENSIONS

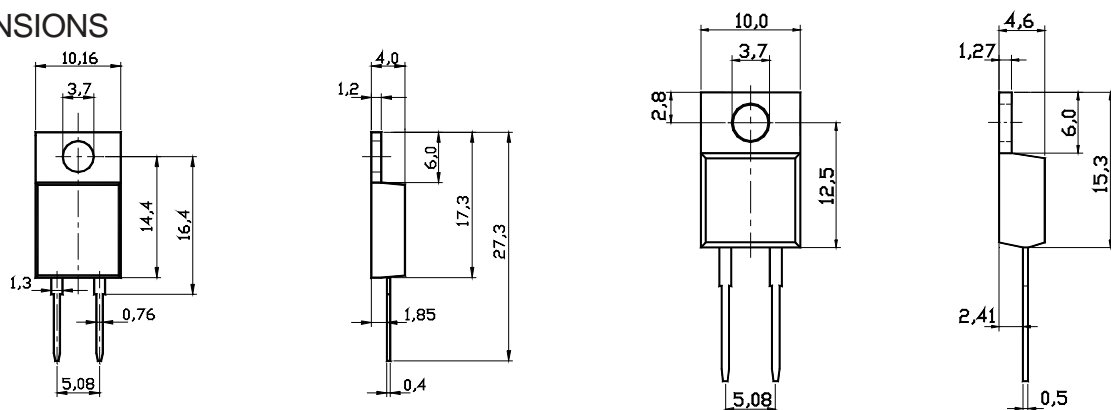

NPR2-T220X upon request possible
(Version with longer leads)
25W with heatsink

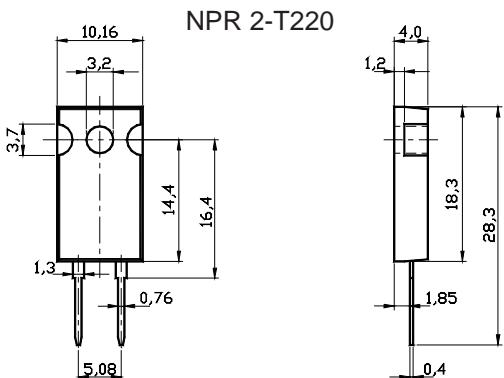

NPS 2-T220

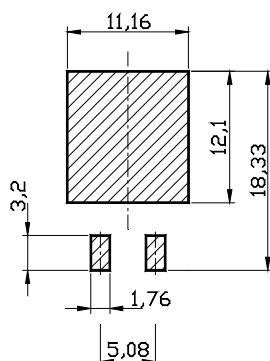

Dimensions in mm

HOW TO ORDER NPR 2-T220 22K 1%

NHR 2-T220/T221

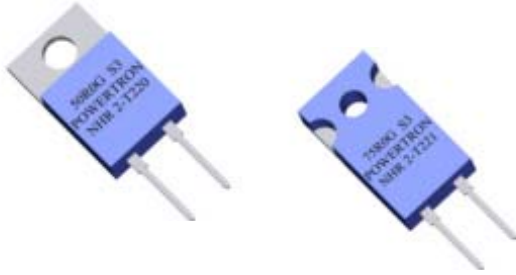

- Highest Power Rating
- Small Dimensions
- Easy to use
- Low Inductance
- TO220-Housing
- SMD Version available

SPECIFICATIONS

ELECTRICAL

Resistance Range	:	0R020 ... 15K
Power Rating	:	1.5 W (70°C) 50 W with heatsink
Tolerances	:	
from 0R020	:	2%, 5%
from 1R0	:	1%, 2%, 5%
Thermal Resistance Rthj-c	:	2.1 K/W
Stability	:	0.5%
Temperature Coefficient	:	
0R02 ... 0R049	:	±600 ppm/K
0R05 ... 0R099	:	±300 ppm/K
0R1 ... 15k0	:	±100 ppm/K
Voltage Proof	:	1.5 kVDC

Max. Voltage

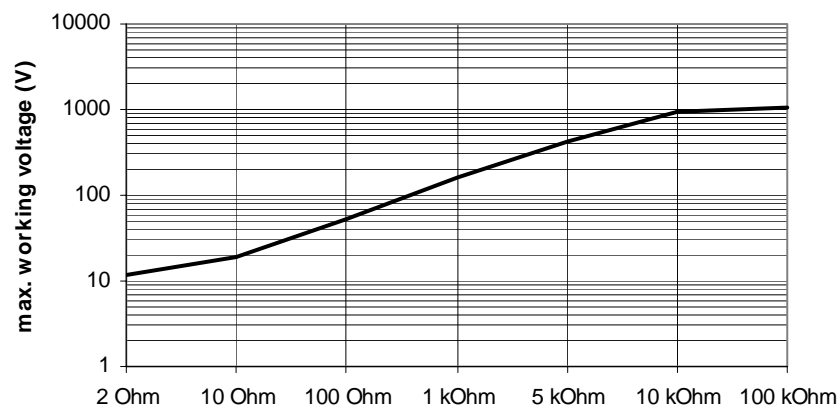

ENVIRONMENTAL

Operative Temperature Range	:	-55°C...155°C
------------------------------------	---	---------------

MECHANICAL

Resistor Material	:	Thick Film
Substrate	:	Al ₂ O ₃
Housing	:	PPS
Connector Material	:	Cu tinned
Max. Torque backplate	:	1 Nm / T221: 0.8 Nm

DERATING CURVE

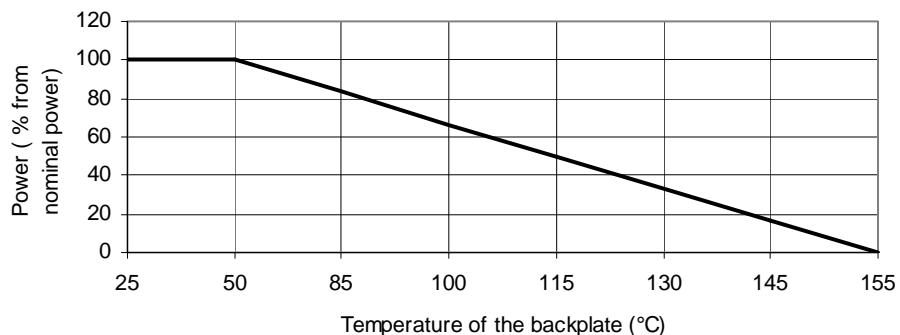

DIMENSIONS

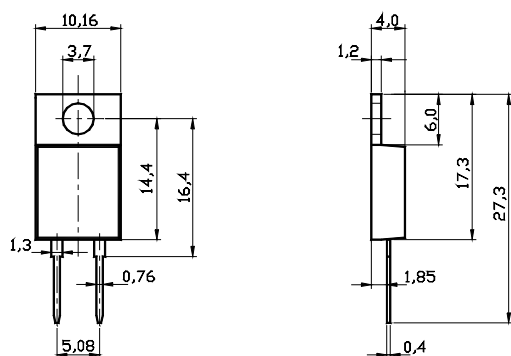

NHR 2-T220

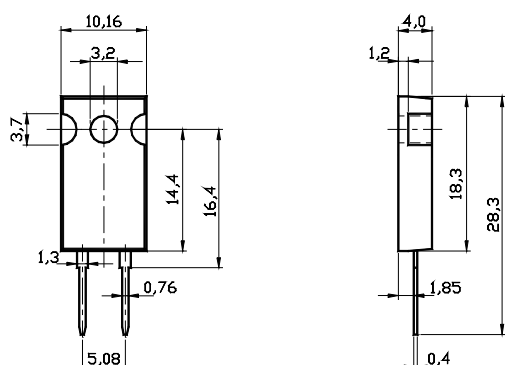

NHR 2-T221

Dimensions in mm

HOW TO ORDER
NHR 2-T220 10K 1%

KPR KPN 2-T227 4-T227
KHR KHN 2-T227 4-T227



- Thick Film Power Resistor
- Power rating from to 200W
- Low Inductance
- For High Impulses
- SOT227-Housing

SPECIFICATIONS

ELECTRICAL

	KPR 2/4-T227	KHR 2/4-T227
	KPN 2-T227	KHN 2-T227
Resistance Range	: 0R05 ... 5M	0R05 ... 5M
Power Rating	: 100 W	200 W
	with heatsink	
Thermal Resistance R_{thj-c}	: 0.70 K/W	0.35 K/W
Tolerances	:	
	from 0R05	2%, 5%, 10%
	from 0R1	1%, 2%, 5%, 10%
Stability	: 1%	
Temperatue Coeffizient	:	
	0R05 ... 0R099	±300 ppm/K
	0R1 ... 5M	±100 ppm/K
		±50 ppm/K upon request
Voltage Proof	: 2,5 kVDC	
Inductivity	: ≤ 50 nH	
Capacity	: ≤ 35 pF	
Max. Voltage		

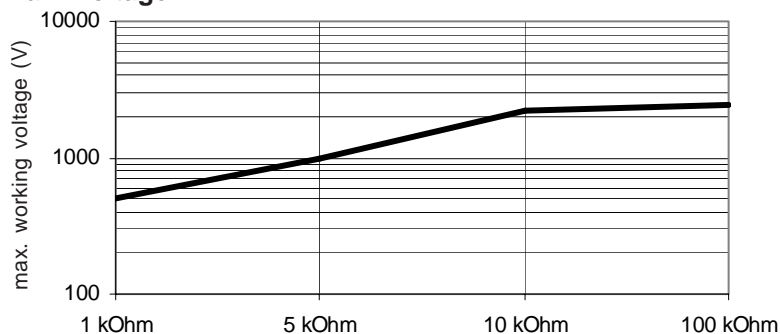

ENVIRONMENTAL

Operative Temperature Range : -55°C ... 155°C

MECHANICAL

Resistor Material : Thick Film
Substrate : Al₂O₃
Connector Material : Cu, tinned, 2 or 4 pol
Max. Torque backplate : 1.5 Nm
Max. Torque terminals : 1.3 Nm

KPR KPN 2-T227 4-T227
KHR KHN 2-T227 4-T227



TEMPERATURE COEFFICIENT

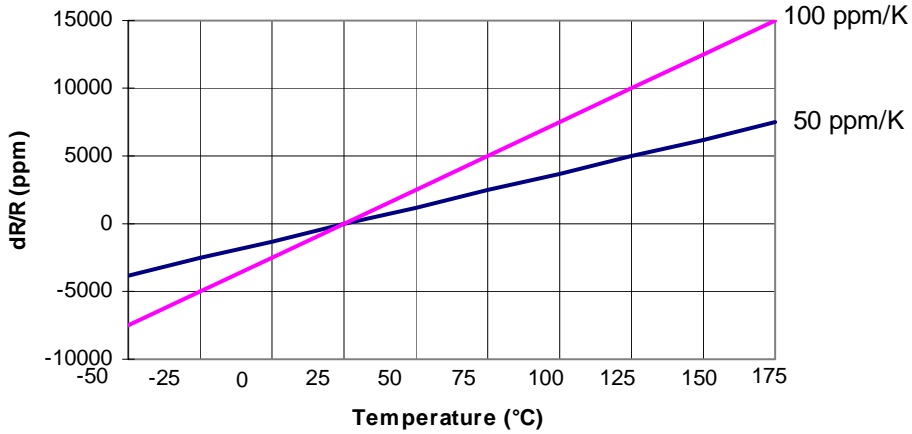

DERATING CURVE

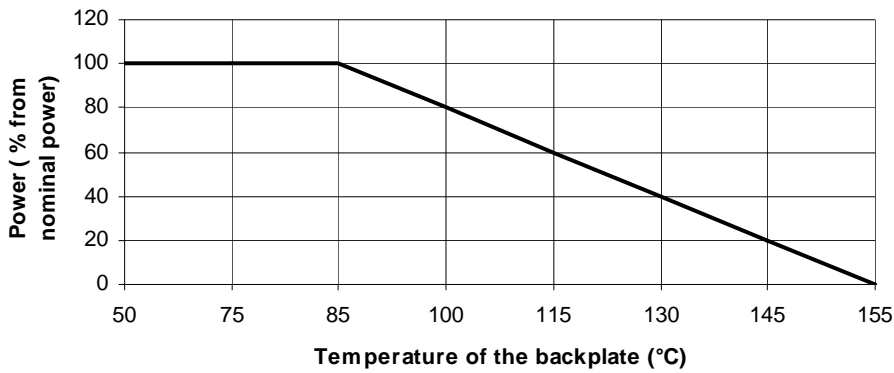

DIMENSIONS

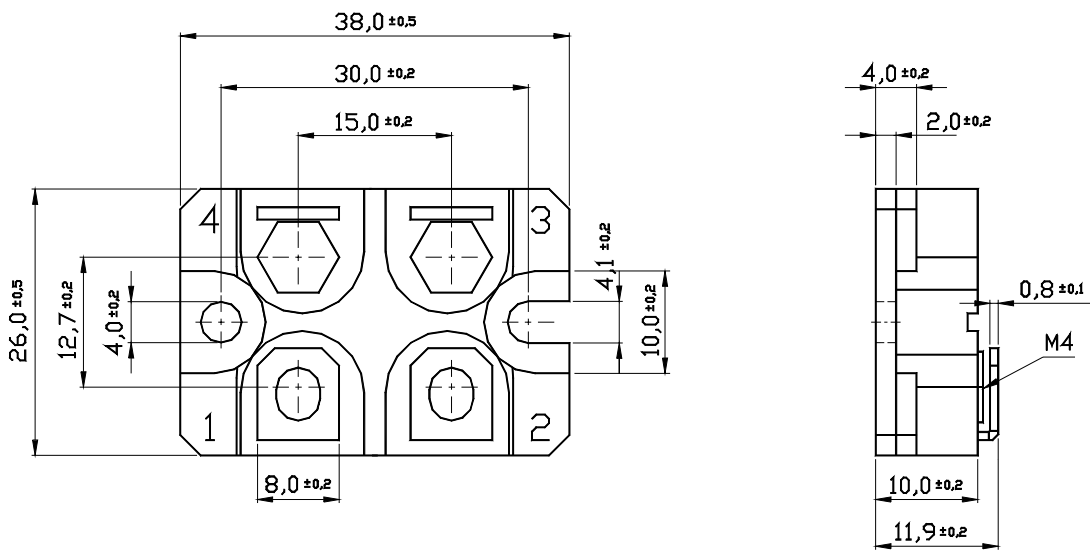

Standardcontact: G

Dimensions in mm

KPR KPN 2-T227 4-T227
KHR KHN 2-T227 4-T227



CONNECTION VARIATIONS

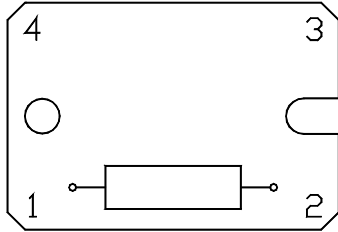

KPR / KHR 2-T227

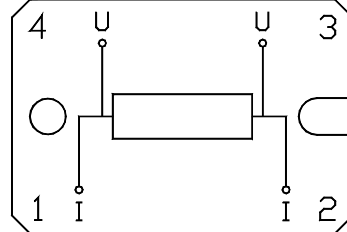

KPR / KHR 4-T227

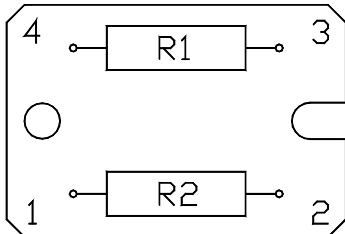

**KPN/KHN 2-T227
(Doppelwiderstand)**

STABILITY AGAINST IMPULSES

Reference values without additional heatsink

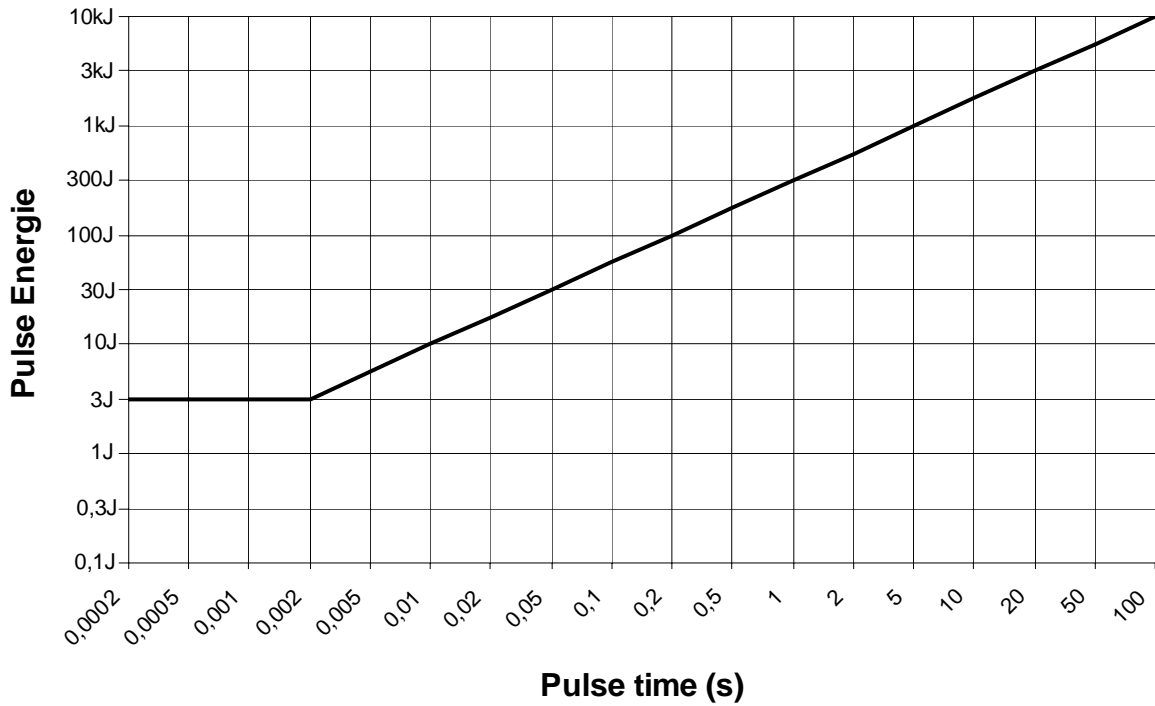

HOW TO ORDER

KPR 2-T227 50R 10%
 KPN 2-T227 220R/220R 5%

KHR 4-T227 10R 2%
 KHN 2-T227 10R-22R 5%

SPECIAL RESISTORS

Special-Resistors

Type	Resistance Range	Power max.	Temperature Coefficient	Tolerance	Stability	Page
FHR 4-4026	0R0005 ... 10R	25 Watt	± 15ppm/K	0.25%	0.5%	115
FPR 4-7705	650µR, 750µR	0.25 Watt	± 25ppm/K	3.0%	0.5%	117
WPR 2-TO5	50R ... 600k	0.25 Watt	± 5ppm/K	0.01%	0.1%	119
FHR 4-2036 D/D	0R035	5 Watt	± 15ppm/K	0.2%	0.5%	121
FHR 4-2820H	0R001 ... 0R01	10 Watt	± 30ppm/K	1.0%	0.5%	123
UHR 4-5020D	1R0 ... 40R0	8 Watt	± 5ppm/K	0.1%	0.1%	125
UHN 2-3825 D	50R0 x 2	30 Watt	± 5ppm/K	1.0%	0.01%	127
CAL 4-40100	0R0001...10k	3 Watt	± 10ppm/K	0.02%	0.02%	129

FHR 4-4026H



- **Extremely Low-Ohm**
- **High Stability**
- **Low Temperature Coefficient**
- **Low Inductance**
- **Customized Resistor Values**

SPECIFICATIONS

ELECTRICAL

FHR 4-4026H

Resistance Range	:	0R0005 ... 10R0
Power Rating	:	15 W (70°C)
Tolerances	:	
0R0005	:	1%
0R010	:	0.5%, 1%
0R020	:	0.25%, 0.5%, 1%
Thermal Resistance	:	4.0 K/W
Thermal EMF	:	< 1 μ V/K
Max. Current	:	100 A

ENVIRONMENTAL

Operating Temperature Range : -40°C...130°C

MECHANICAL

Resistor Material	:	CuNiMn (DIN 17471)
Substrate	:	anodized aluminium
Connector	:	Powersocket RM 2.54 / 16 Pin 4-pol other contacts upon request

DERATING CURVE

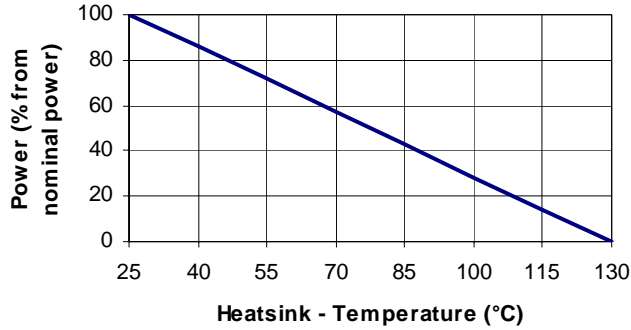

DIMENSIONS

FHR 4-4026HH

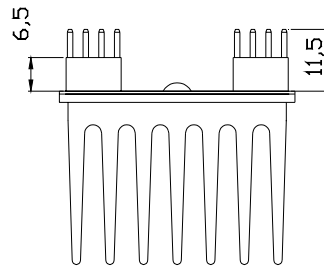
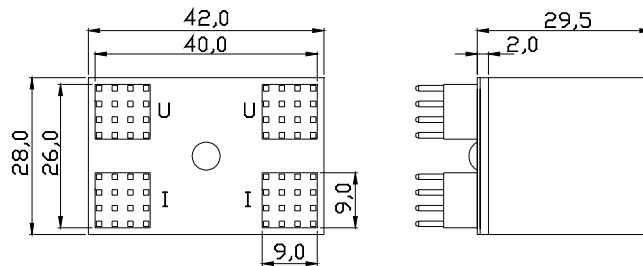

FHR 4-4026HM6

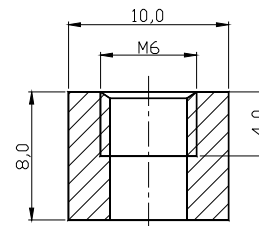
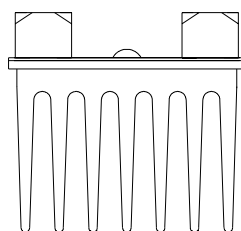
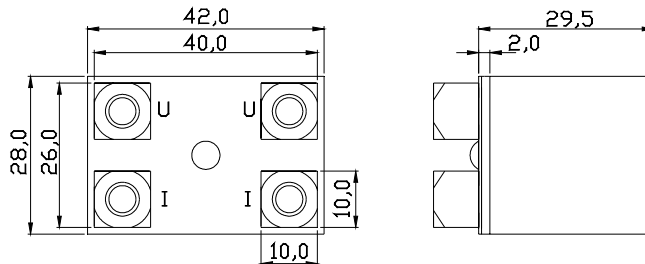

Dimensions in mm

HOW TO ORDER

FHR 4-4026H 0R001 1%



- **Extremely Low-Ohm**
- **High Stability**
- **Low Temperature Coefficient**
- **Low Inductance**
- **Customized Resistor Values**

SPECIFICATIONS

ELECTRICAL

FPR 4-7705

Resistance values	:	650 $\mu\Omega$, 750 $\mu\Omega$ other resistance values upon request possible
Power Rating	:	0.25 W (70°C)
Tolerances	:	3%, 5% other tolerances upon request
Thermoelectric voltage difference of the Sense-leads	:	max. 1 μ V
Temperature Coefficient	:	\pm 25ppm/K (20...80)°C
Max. Current	:	20 A
Limiting Frequency	:	50 MHz

ENVIRONMENTAL

Operating Temperature Range	:	-40°C...130°C
------------------------------------	---	---------------

MECHANICAL

Resistor Material	:	CuNiMn (DIN 17471)
Connector Material	:	Copper, nickeled
Sense-leads	:	CuNiMn (DIN 17471)

DERATING CURVE

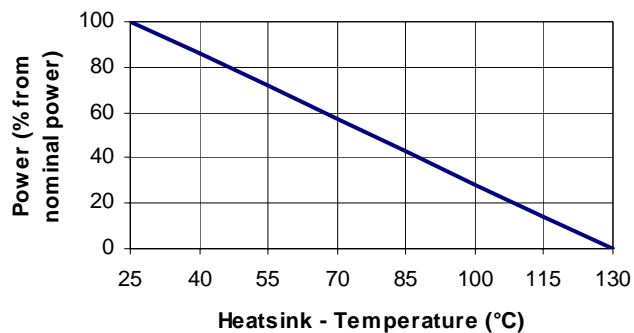

DIMENSIONS AND CONTACTS

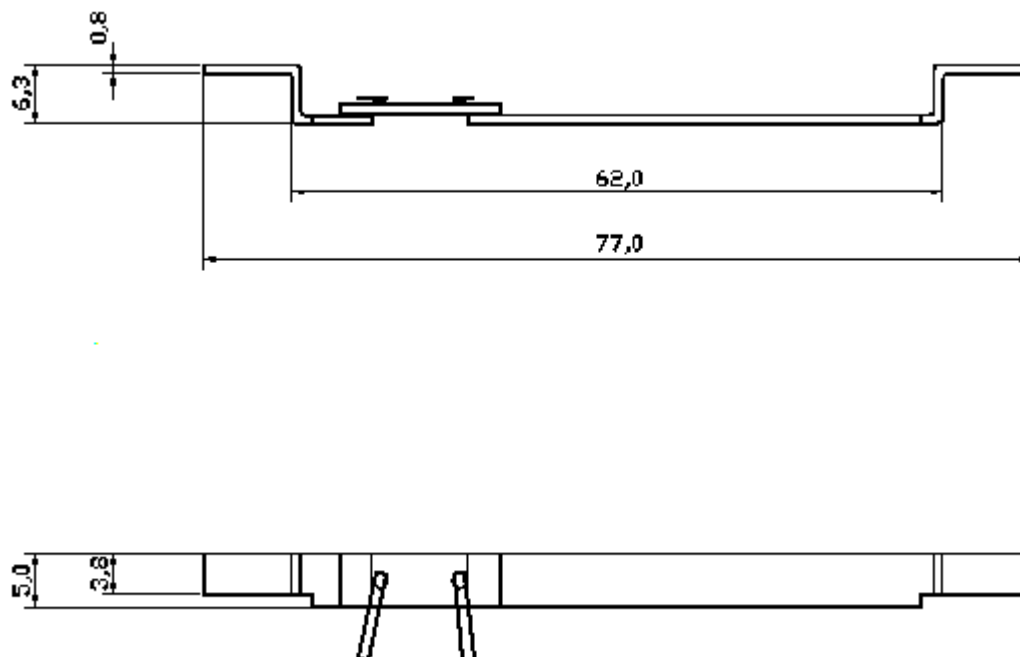

Dimensions in mm

HOW TO ORDER
FPR 4-7705 0R000650 3%



- Hermetically Sealed
- Highest Stability
- Lowest Tolerances
- Low Temperature Coefficient
- Small Dimensions (TO5)
- Customized Resistance Values

SPECIFICATIONS

ELECTRICAL

	WPR 2-TO5
Resistor Range	: 50R0 ... 600k Other values upon request possible
Power Rating	: 0.25 W (70°C)
Tolerances	: 0.01%, 0.1%, 0.25%, 0.5%, 1% Other tolerances possible
Stability	: 0.1 %
Temperature Coefficient	: $\pm 5\text{ppm/K}$ (-40...+125)°C
Insulation Resistance	: 300VDC
Thermal EMF	: $<1\mu\text{V/K}$

ENVIRONMENTAL

Operating Temperature Range	: -55°C...130°C
------------------------------------	-----------------

MECHANICAL

Resistor Material	: NiCr
Connector Material	: Cu, gold-coat

DERATING CURVE

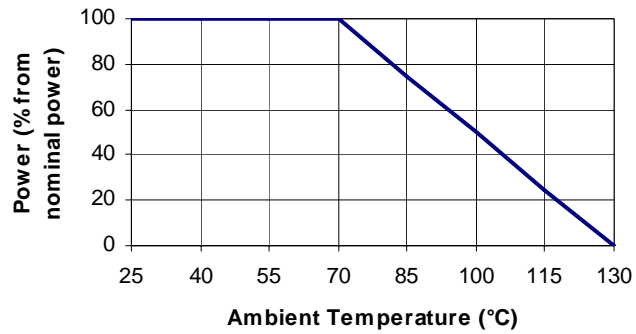

DIMENSIONS

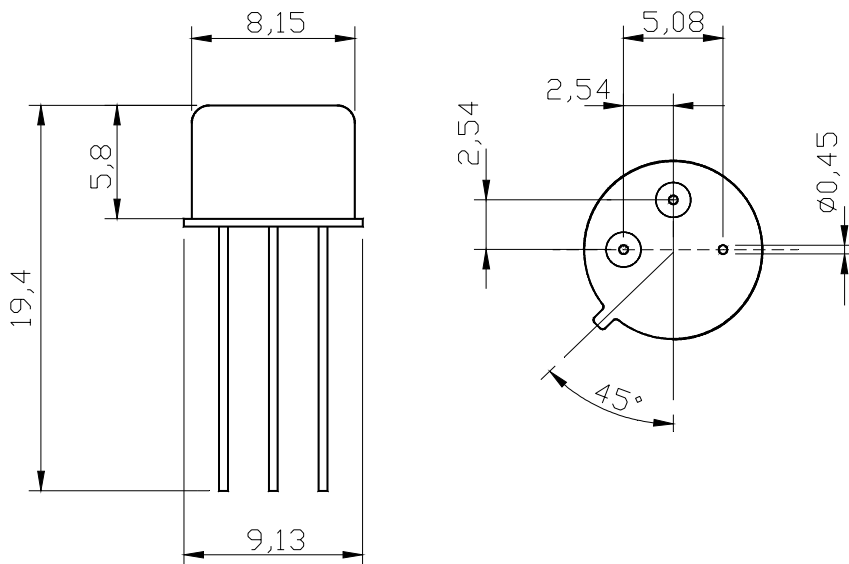

Dimensions in mm

HOW TO ORDER
WPR 2-TO5 330R0 0.01%



- High Impulse Energy
- High Stability
- Low Tolerances
- Low Temperature Coefficient
- Low Values
- Customized Resistance Values

SPECIFICATIONS

ELECTRICAL

		FHR 4-2036 D/D
Resistor Range	:	0R035 Other values upon request possible
Power Rating	:	5 W (70°C)
Max. Pulse Energy	:	350J / 500ms
Thermal Resistance	:	12 K/W
Tolerances	:	0.2% Other tolerances upon request
Stability	:	0.5 %
Temperature Coefficient	:	±15ppm/K (20...+60)°C
Insulation Resistance	:	500VDC
Max. Current	:	12A
Thermal EMF	:	<1µV/K

ENVIRONMENTAL

Operating Temperature Range	:	-40°C...130°C
------------------------------------	---	---------------

MECHANICAL

Resistor Material	:	CuNiMn
Substrate	:	Al
Connector Material	:	Cu, tinned

TEMPERATURE COEFFICIENT

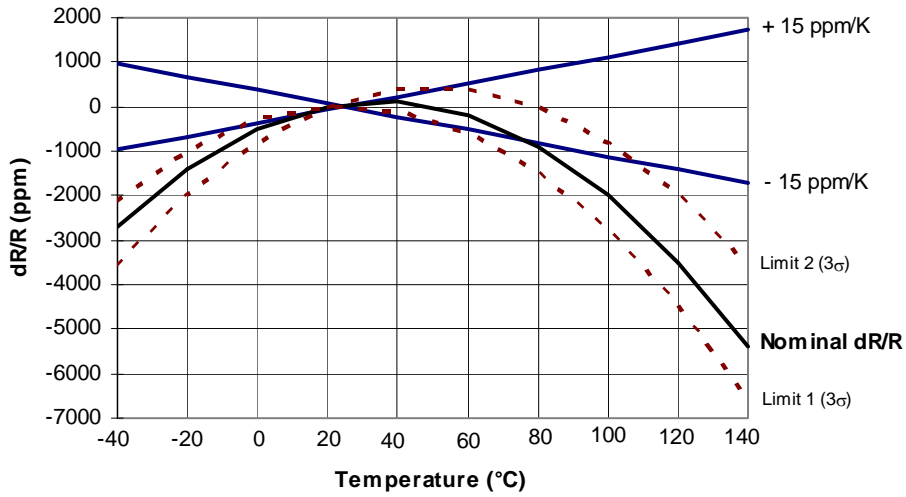

DERATING CURVE

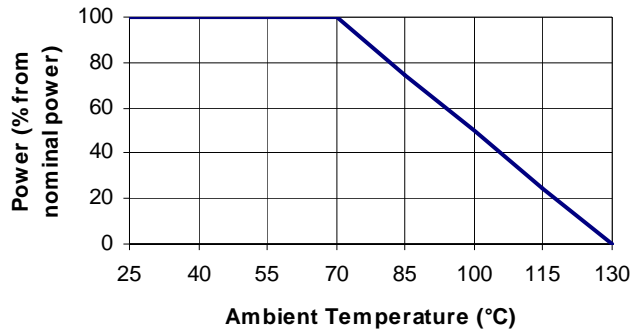

DIMENSIONS

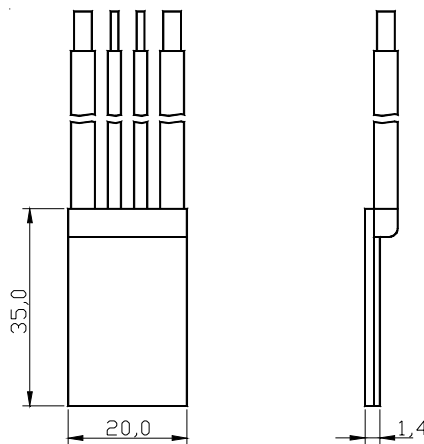

Dimensions in mm

HOW TO ORDER

FHR 4-2036 D/D 0R035 0.02%



- **Extremely Low-Ohm**
- **High Stability**
- **Low Tolerances**
- **Low Temperature Coefficient**
- **Small Dimensions**
- **Customized Resistance Values**

SPECIFICATIONS

ELECTRICAL

	FHR 4-2820 H
Resistor Range	: 0R001 ... 0R01 Other values upon request
Power Rating	: 3 W (70°C) without heatsink 10 W with heatsink
Thermal Resistance Rthj-c	: 8 K/W
Tolerances	: 1%, 5% Other tolerances upon request
Stability	: 0.5 %
Temperature Coefficient	: ± 30 ppm/K (20 ... 60)°C
Insulation Resistance	: 50VDC
Max. Current	: 100A
Thermal EMF	: $<1\mu$ V/K

ENVIRONMENTAL

Operating Temperature Range	: -40°C...130°C
------------------------------------	-----------------

MECHANICAL

Resistor Material	: CuNiMn
Substrate	: Al
Connector Material	: Cu, tinned

TEMPERATURE COEFFICIENT

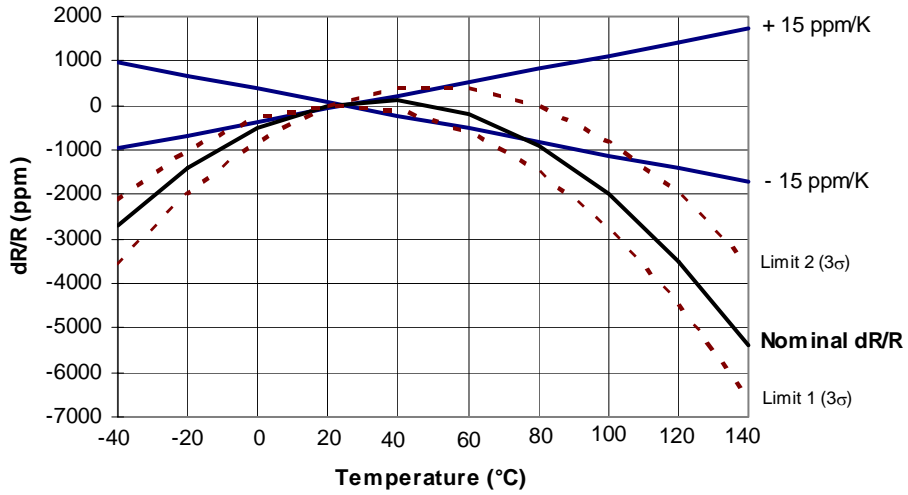

DERATING CURVE

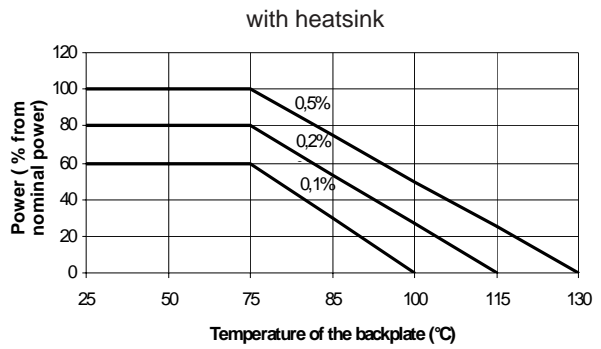
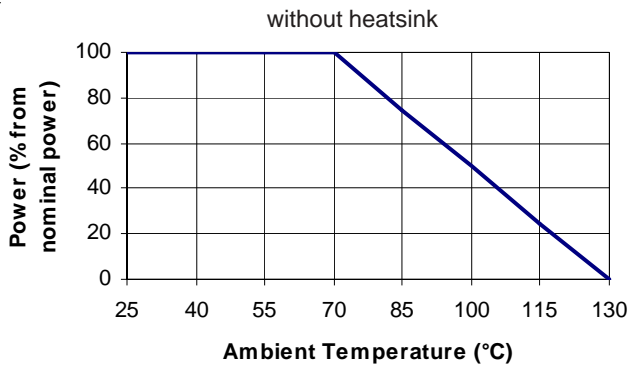

DIMENSIONS

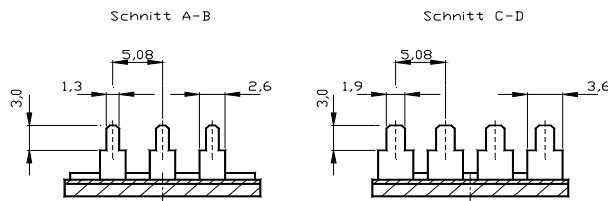
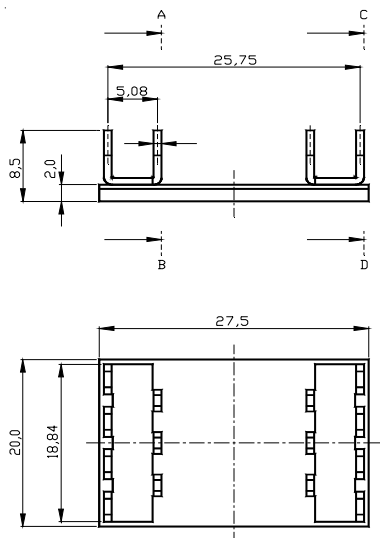

Dimensions in mm

HOW TO ORDER

FHR 4-2820 H 0R01 1%

UHR 4-5020 D



- Highest Pulse Energy
- highest Stability
- Lowest Tolerances
- Low Temperature Coefficient
- Special Housing
- Customized Resistance Values

SPECIFICATIONS

ELECTRICAL

		UHR 4-5020 D
Resistor Range	:	1R0 ... 40R0 Other values upon request possible
Power Rating	:	8 W (70°C)
Pulse Energy	:	1 kJ / 1s
Thermal Resistance	:	10 K/W
Tolerances	:	0.1% Other tolerances upon request
Stability	:	0.1 %
Temperature Coefficient	:	±5ppm/K (-55...+155)°C
Insulation Resistance	:	3kVDC
Max. Current	:	3A
Thermal EMF	:	<1µV/K

ENVIRONMENTAL

Operating Temperature Range	:	-55°C...155°C
------------------------------------	---	---------------

MECHANICAL

Resistor Material	:	NiCr
Substrate	:	AlN
Housing	:	Al
Connector Material	:	Cu, tinned

TEMPERATURE COEFFICIENT

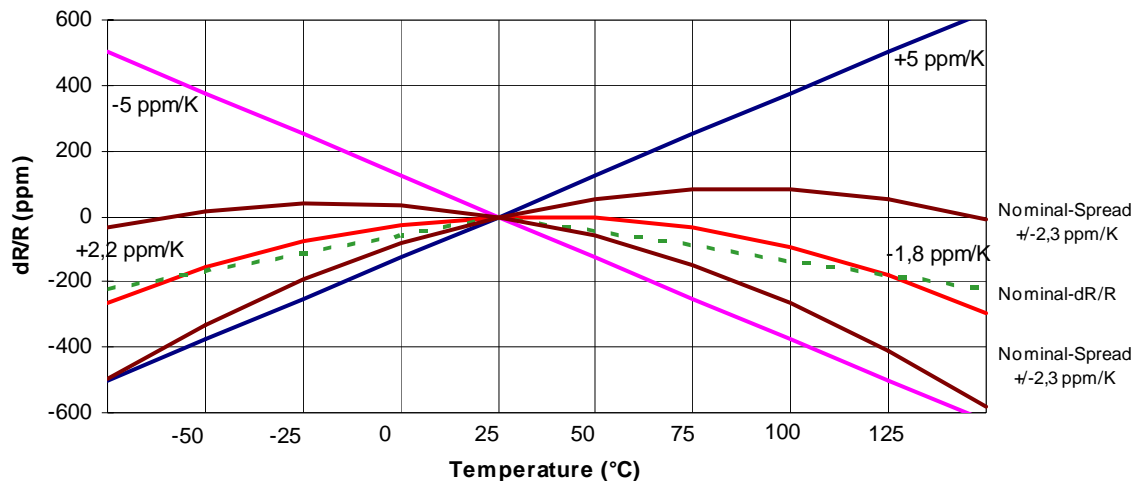

DERATING CURVE

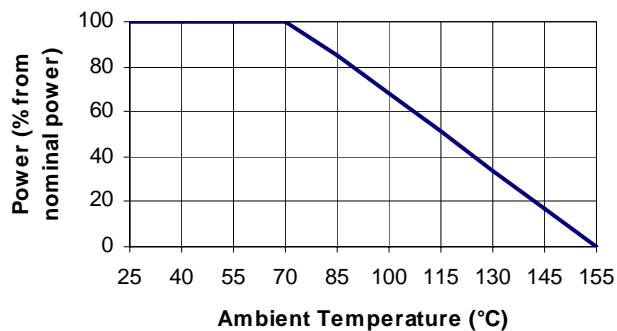

DIMENSIONS

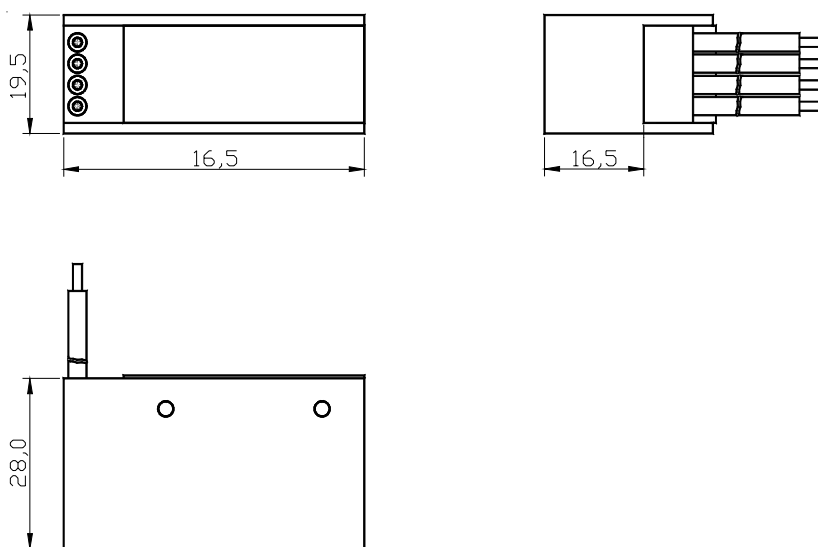

Dimensions in mm

HOW TO ORDER

UHR 4-5020 D 10R0 0.1%



- **Highest Stability**
- **Lowest Tolerances**
- **Low Temperature Coefficient**
- **Customized Resistance Values**

SPECIFICATIONS

ELECTRICAL

UHN 2-3825 D

Resistor Range	:	50R0 (2x) Other values upon request
Power Rating	:	3 W (70°C) without heatsink 30 W with heatsink ($\vartheta_{KK} = 25^{\circ}\text{C}$)
Thermal Resistance Rthj-c	:	3.5 K/W
Tolerances	:	1% (0.1% Difference between the two resistances) Other tolerances upon request
Stability	:	0.01 %
Temperature Coefficient	:	$\pm 5\text{ppm/K}$ (-55...+155)°C
Insolation Resistance	:	500VDC
Max. Current	:	15A
Thermal EMF	:	<1 $\mu\text{V/K}$

ENVIRONMENTAL

Operating Temperature Range	:	-55°C...155°C
------------------------------------	---	---------------

MECHANICAL

Resistor Material	:	NiCr
Substrate	:	Al ₂ O ₃
Housing	:	Al, Epoxy
Connector Material	:	Cu, tinned
Max. Torque backplate	:	1 Nm

TEMPERATURE COEFFICIENT

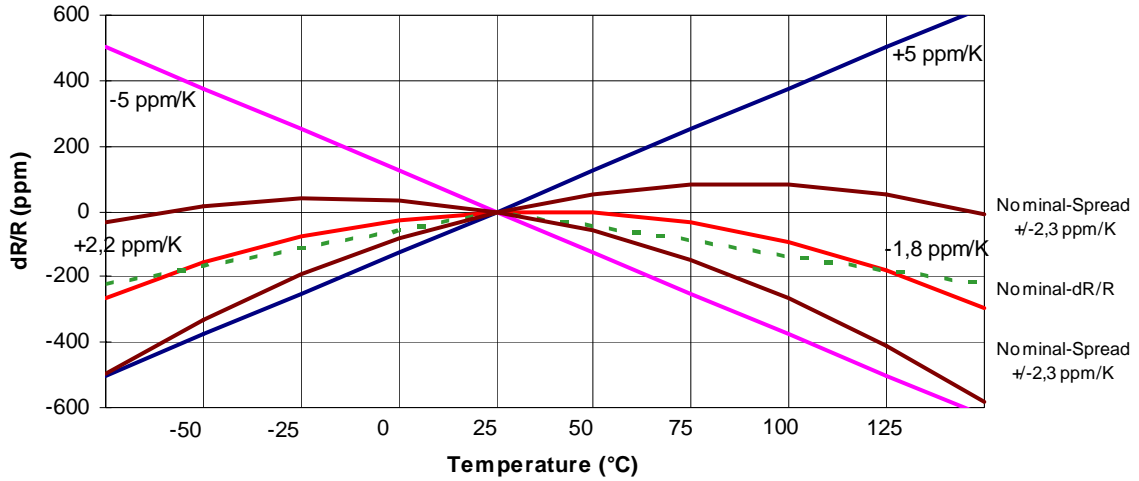

DERATING CURVE

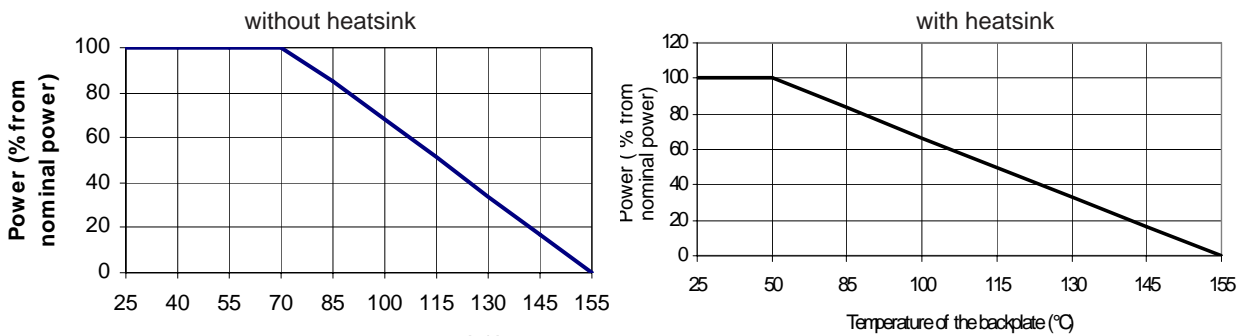

DIMENSIONS

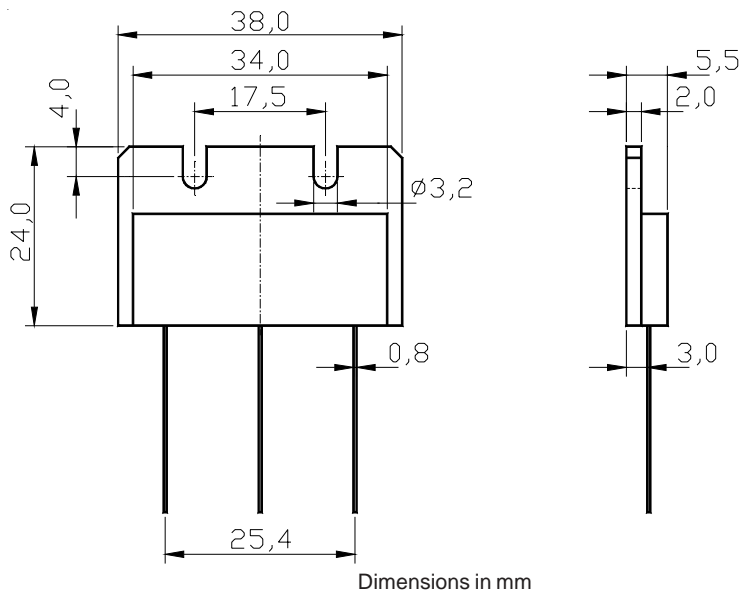

HOW TO ORDER

UHN 2-3825 D 50R0-50R0 0.5%

CAL 4-40100

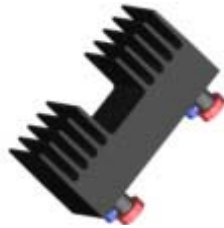

- **Calibration Resistor**
- **Resistance Values**
100 $\mu\Omega$ up to 10k Ω
- **Low Tolerances**
0.1% up to 0.02%
- **Very good Long-term Stability**
- **High Power Capacity**
- **DKD-Calibration as Option**

SPECIFICATIONS ELECTRICAL

CAL 4-40100

Resistance Value	Tolerance	max. Current
0.0001	0.1 %	60 A
0.0002	0.1 %	60 A
0.001	0.05 %	30 A
0.002	0.05 %	30 A
0.005	0.05 %	20 A
0.01	0.03 %	15 A
0.02	0.03 %	10 A
0.05	0.03 %	5 A
0.1	0.02 %	5 A
0.2	0.02 %	3 A
0.5	0.02 %	2 A
1.0	0.02 %	1.5 A
2.0	0.02 %	1 A
5.0	0.02 %	0.7 A
10	0.02 %	0.5 A
20	0.02 %	0.3 A
50	0.02 %	0.2 A
100	0.02 %	0.15 A
200	0.02 %	0.1 A
500	0.02 %	0.07 A
1000	0.02 %	0.04 A
2000	0.02 %	0.02 A
5000	0.02 %	0.012 A
10000	0.02 %	0.01 A

Long-term stability	:	0.02 % typ. (23 °C for 2.000 h) 0.05 % max. (70 °C for 2.000 h)
Temperature Coefficient	:	<10 ppm/K (20 ... +60)°C
Operating Temperature	:	-20°C ... 70°C

MECHANICAL

Resistor Material	:	CuNiMn
Dimensions	:	(WxHxD) 100 x 70 x 40 mm
Weight	:	ca. 230 g

All Calibration Resistors are shipped with a factory certificate, including type, serial number, resistance value and uncertainty of measurement. (2×10^{-4} / see DKD-3).

Option DKD

Calibration of a Calibration Resistor at a DKD Calibration Laboratory (supervised by the PTB / Physikalisch Technische Bundesanstalt in Braunschweig) with DKD Calibration Certificate.

RESISTORS

APPLICATION NOTES AND DEFINITION OF TERMS

Application

Definition of terms	133
Temperature dependence and TC of the resistor	135
Technical data regarding power and heatsink dimensioning	137
Order nomenclature	140
Application note	
Thermal resistance within real applications	141
Testing Specifications	144

DEFINITION OF TERMS

Nominal resistor value (R_N):	nominal (printed) resistor value, i.e. 22R (value of the order)
absolute resistor value:	real resistor value of the resistor, i.e. 22R0253
Tolerance:	max. allowed deviation of the absolute resistor value from the nominal resistor value in percent from the nominal resistor value (delivery tolerance), i.e. 22R \pm 1%
Accuracy:	resolution / number of digits from the mantissa of the nominal resistor value, i.e. 5K045 (4 digits accuracy) The accuracy is not the tolerance even if there is a cohesion.
Stability:	max. allowed change of the absolute resistor value depending from time and stress. Normally it is mentioned in percent from the absolute resistor value at $t = 0$ (reference value).
Temperature change:	Change of the absolute resistor value dependency of the temperature at the resistance element. It is normally mentioned in ppm (parts per million) of the absolute resistor value at the reference temperature. T_0 (relative change of temperature dR/R).
Temperature coefficient (TC):	relative change of temperature of the absolute resistor value at temperature T relative to the change of temperature ($T - T_0$) For the Ultra-precision resistor the reference temperature T_0 is 25°C. It is mentioned in ppm/K.
TCR-alignment (tracking):	max. allowed TC difference of different resistors (i.e. double-resistors, pair resistors or networks)
Power dissipation:	When applying an electric voltage in a real resistor, the energy is converted into heat. The result of the energy per unit time is the power dissipation ($P = W / t$, $P = U \cdot I$, $P = R \cdot I^2$, $P = U^2 / R$). Depending on the heat removal, there is a temperature rise of the resistance element.

Definition of Terms



Inherent temperature:	real temperature of the resistance element The inherent temperature is the sum of the ambient temperature and the additional temperature of the power dissipation. (excess temperature dT_R).
Limiting temperature:	max. allowed inherent temperature In exceeding the limiting temperature it is possible to have non-reversible alteration of the resistance, a change in its properties or its demolition.
Nominal power dissipation:	max. permanent allowed power dissipation without exceeding the limiting temperature of the resistance. The nominal power dissipation mentioned in the specifications belonging to these conditions: - free-standing assemblage - ambient temperature of 70°C without additional cooling or - assemblage on a heatsink with optimal fixed mounting (pressurized and use of a heat conduction paste)
Thermal resistance (Rth):	factor of proportionality between power dissipation and over-temperature $R_{th} = dT / P$ The specifications mentioned in the data sheet for heatsink mounted resistors (R_{thj-c}) are defined as thermal resistance between the resistance element and case bottom plate.
Impulse strength:	max. allowed short-duration (impulse) electric energy, without exceeding the limiting temperature
Limiting voltage:	also dielectric strength, max. allowed voltage applied to the resistance
Limiting current:	max. allowed current through the resistance
Insulation strength:	also breakdown rating, max. allowed voltage between the resistance element and the environment (i.e. chassis or heatsink)
Standard conditions:	measurement conditions for defining the absolute resistor value, tolerance and stability of the resistor In the laboratory and production process the reference temperature is 25°C ± 2°C.

TEMPERATURE DEPENDENCE AND TC OF THE RESISTOR

The resistance value of a technical resistance is against the ohmic resistance temperature-dependent. In today's modern fields of measurement and electronics, particularly in such industries as heating and ventilation (HVAC), medical technology and in military applications, precision, stability, and dependability are important criterions. Here the highest demands are made on every component. For this reason, the precision and ultra-precision resistors have been developed. The base of the resistance element is a special resistive film. With the use of special technological steps we are able to synchronize the substrate and the resistor material. This means that we can produce resistors with a very low temperature coefficient.

1. Ultra-precision-resistors (series USR/USN, UNR, UHR and UPW)

Picture 1 - $dR/R(T)$ for the series USR/USN, UNR and UHR

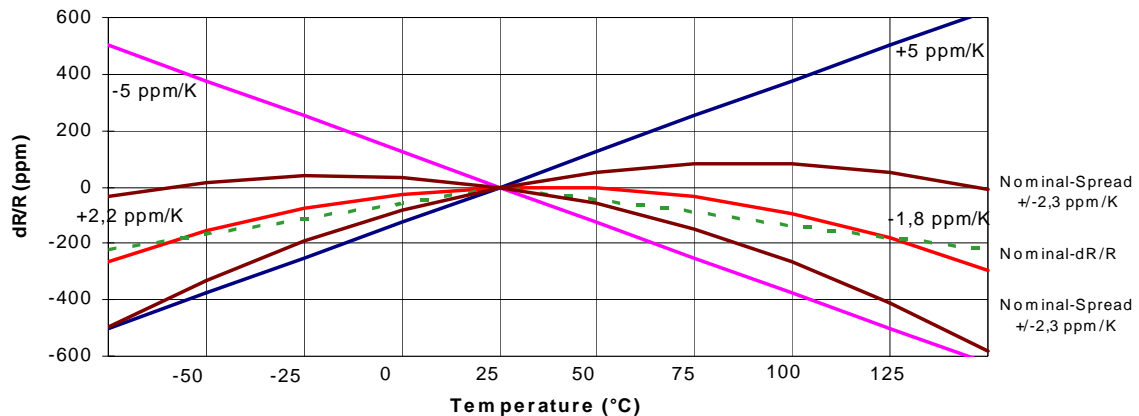

The TC adjustment is per charge at the reference temperature of 25°C (T_0).

For the series USR/USN as well as UNR and UHR when adjusting the $dR/R(T)$ -curve, we are able to reach a TC_1 of -1.8 ppm/K with an inherent temperature of 125°C (T_1) and a TC_2 of $+2.2 \text{ ppm/K}$ with an inherent temperature of -55°C (T_2). These curves are mentioned as the nominal dR/R -curves or the nominal TCs (Picture 1)

The specific TC is mathematical the rise of the secant between $dR/R(T_{1,2})$ and $dR/R(T_0)$.

Normally there is a spread of values when the TC-adjustment is made. The reason for this belongs to the technical process and the normal difference in the materials. Therefore it is possible that the real $dR/R(T)$ -curves, the TK_1 and TK_2 of all the resistors varies from the nominal mentioned parameters.

In the normal production process and big charges the TCs of all resistors are within the Gaussian distribution.

For the series USR/USN as well as UNR and UHR the nominal spread is $\pm 2.3 \text{ ppm/K}$ (for TK_1 as well as TK_2). This is the 3σ -area.

The TCs of 99.73% of all resistors in one charge belong to this area (Picture 2).

Picture 2 - nominal distribution of the TCs - series USR/USN and UNR

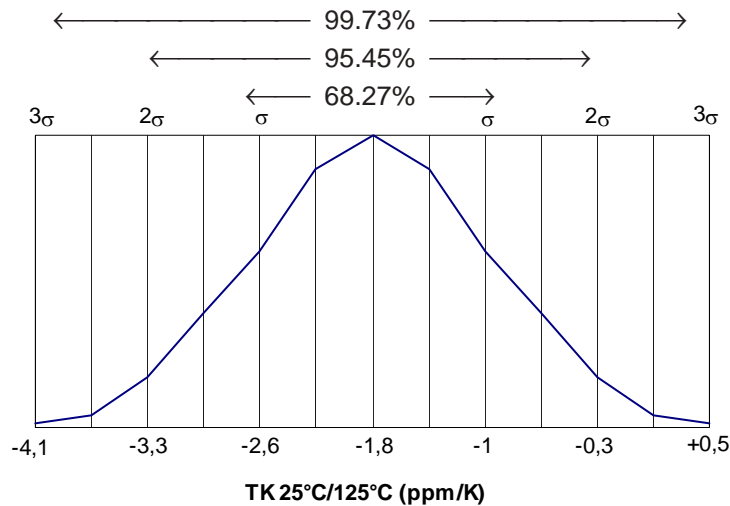

For a reduced temperature range from 0...60°C the nominal TCs are -0.6 ppm/K / +0.6 ppm/K and the nominal spread (3σ-area) of one charge is at ±2.5 ppm/K.

Upon customer request we can measure each resistor to secure that the TC in the temperature range of 25...60°C of all delivered resistors is ±1.0 ppm/K.

For the series UPW the TK₁ is -3.6 ppm/K and the TK₂ is +4.4 ppm/K. The nominal spread of the TCs of all resistors of one charge is at 25°C ±2.8 ppm/K.

2. Precision-Resistors (series FPR/FPN, FHR/FHN and FNR/FNN)

Picture 3 - dR/R (T) for the series FPR/FPN, FHR/FHN and FNR/FNN

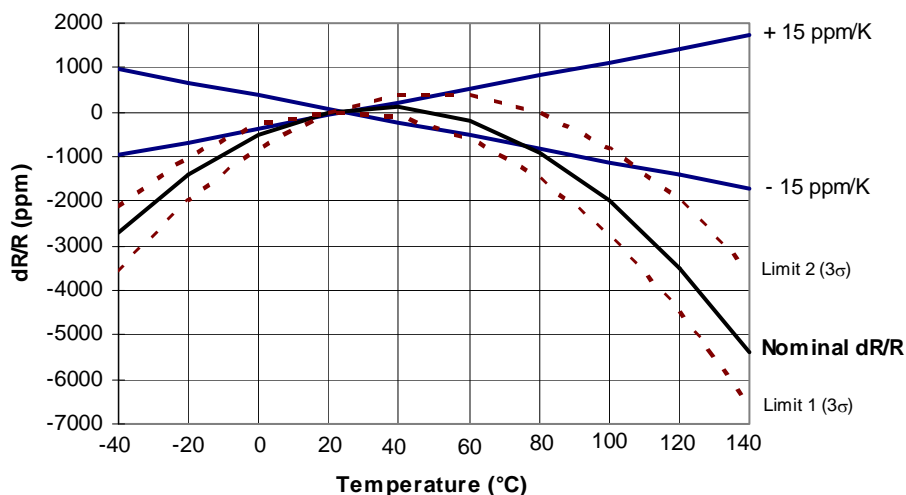

The dR/R (T)-curve of the precision-resistors series FPR, FHR and FNR as well as the precision-networks series FPN, FHN and FNN compared with the ultra-precision-resistor series USR/USN, UNR and UHR is more curved.

Even then we can reach nominal-TCs in a temperature range of 20...60°C smaller than ± 15 ppm/K and in a temperature range of 20...40°C smaller than ± 10 ppm/K. This is possible through the use of a 4-pol technology. The current intake and the voltage tapping are separated (Kelvin-connection).

In picture 3 the middle nominal dR/R (T)-curve as well as the border-curves of the nominal spread (3σ - area) are mentioned. These curves are only for low-ohm values used with a 4-pol connection.

For 2-pol resistors the influence of the contact-elements to the TCs of the complete resistance is very big. In picture 4 the change of the TC for 2-pol resistors is mentioned (depending on the nominal resistor value).

Bild 4 - TC-shift (low-ohm 2-pol resistors)

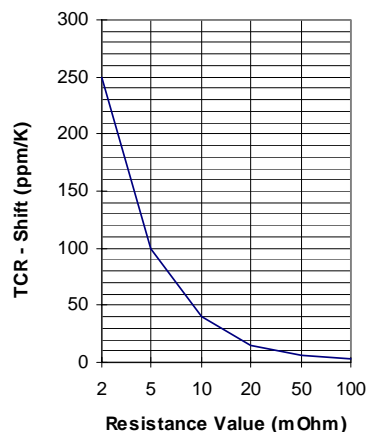

TECHNICAL DATA REGARDING POWER AND HEAT SINK DIMENSIONING

In the data sheets the nominal power dissipation is mentioned for all resistors. The data are mentioned for a free standing assemblage i.e. SMD assembling on a PCB. The ambient temperature is always 70°C. This means that the inherent temperature of the resistance element will reach without a additional cooling the limiting temperature.

The inherent temperature is the sum of the ambient temperature and the temperature through the power dissipation. If the ambient temperature is higher than 70°C the power dissipation must be reduced to secure that the resistance element will not exceed the limiting temperature. Otherwise the element will might be damaged.

This necessary reduction of the power dissipation is denoted as „derating“. In the data sheets a „derating curve“ (Picture 5) is always mentioned. The value of the specific power dissipation depends on the ambient temperature in % of the nominal power dissipation.

Picture 5 - Derating-Curve of a free standing resistor series *USR/USN, UNR, UHR, UPW* without additional cooling

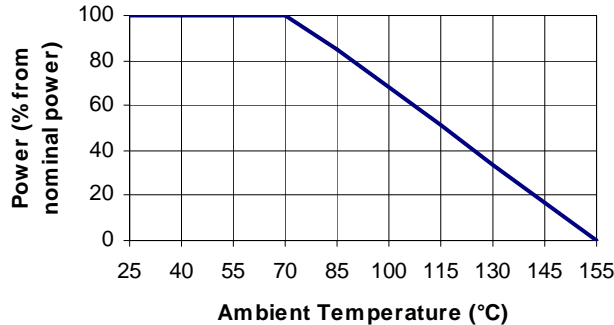

If the ambient temperature reach the limiting temperature of the element, it is not possible to electrically stress the element.
 If the ambient temperature is lower than 70°C, it is possible to stress the element with a higher power than mentioned in the data.
 A supplementary increase of the power dissipation is possible, if an additional cooling system is attached (i.e. heatsink, forced air blast).
 The best advantage is the forced air blast with a ventilating fan. With this additional cooling the heat convection of the resistor is higher.
 For a global calculation: with a forced air blast of 3 m/s and an optimal placed construction, it is possible to double the power dissipation.

Another possibility is the use of a heatsink. With a heatsink the surface of the resistor is bigger, and therefore the convection is higher.
 For all resistor series we have constructed elements with a possibility to use a heatsink (i.e. housings like TO 220 and TO 218).
 In the data sheets the nominal power dissipation in use with a heatsink is mentioned. The specifications belong to these conditions:
 - assemblage on a heatsink with optimal fixed mounting (pressurized and use of a heat conduction paste)
 - temperature of the heatsink 25°C (for power resistors 40°C)

If the resistor is installed on a heatsink, the derating curve looks different from the freestanding assemblage. The power dissipation depends on the temperature of the case bottom plate (picture 6).

Picture 6 - Derating-Curve of a resistor (optimal assembling on a heatsink)

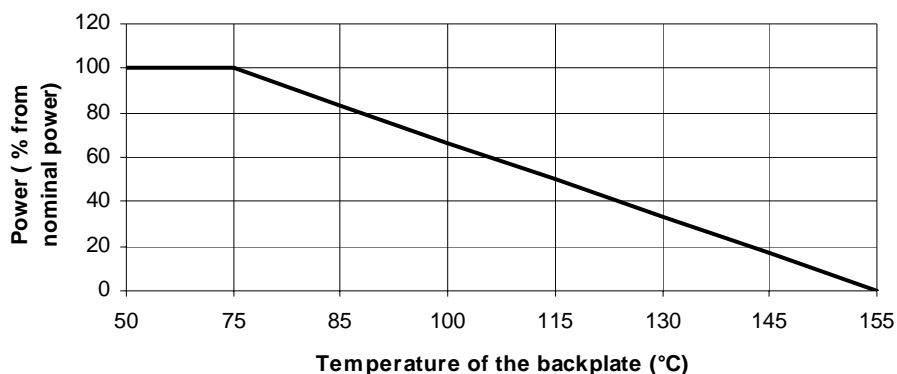

The max. allowed power dissipation depends on the temperature of the heatsink, because the inherent temperature is the sum of the heat from the power dissipation (regarding the heatsink temperature) and the heatsink temperature itself.

For the max. allowed power dissipation this condition is valid: $T_{\text{resistor}} = dT_{\text{R}} + T_{\text{KK}} = T_{\text{limit}}$.

The temperature of the heatsink results in the over-temperature of the heatsink itself (dT_{KK}) and the ambient temperature of the whole application.

Valid is: $T_{\text{limit}} = dT_{\text{R}} + dT_{\text{KK}} + T_{\text{ambient}}$

In protection to the electrical technology we obtain the factor of proportionality between the power dissipation and the over-temperature:

the thermal resistance $R_{\text{th}} = dT / P$

For the resistor and the used heatsink the following condition is valid: $R_{\text{thR}} = dT_{\text{R}} / P$ or $R_{\text{thKK}} = dT_{\text{KK}} / P$

In order to calculate the max. power we have to use following equation which results from the former equations:

$$P_{\text{max}} = (T_{\text{limit}} - T_{\text{ambient}}) / (R_{\text{thR}} + R_{\text{thKK}}); (R_{\text{thR}} = R_{\text{thAppI}} + R_{\text{thj-c}})$$

For all heatsink mounting resistors the mentioned data for the thermal resistance are for an optimal assemblage. The thermal resistance for the heatsink must be obtained from the manufacturer of the heatsink.

Example 1:

We are assembling a *USR 2-T220* on a heatsink with a thermal resistance of 7 K/W. We want to know the maximal power dissipation (ambient temperature 25°C) ?

Solution:

$$P_{\text{max}} = (155^{\circ}\text{C} - 25^{\circ}\text{C}) / (13 \text{ K/W} + 7 \text{ K/W}) = 6.5 \text{ W}$$

In a freestanding application the maximal power dissipation is 2.3 W.

Another application for heatsink mounted resistors is the possibility to reduce the change of the resistor value (through the temperature change) and to increase the stability. The inherent temperature will be constant at the same power dissipation.

In order to calculate the inherent temperature (the power dissipation is fixed) we need the following equation:

$$T_{\text{resistor}} = P * (R_{\text{thR}} + R_{\text{thKK}}) + T_{\text{ambient}}$$

In order to calculate the thermal resistance of a heatsink (application is fixed) we have this equation:

$$R_{\text{thKK}} = (T_{\text{resistor}} - T_{\text{ambient}}) / P - R_{\text{thR}}$$

Example 2:

The temperature change of an 2.5Ohm measuring resistor must be lower than 40ppm if there is a stress current of 1A. To reach this we are using a resistor of the series USR with TCR 1. The maximal inherent temperature of this resistor is 60°C. The ambient temperature in the application (i.e. Measurement Equipment) is 35°C. The question is which resistor type and which heatsink do we have to use?

Solution:

The power dissipation is $P = R \cdot I^2 = 2.5 \text{ W}$.

The first resistor we are choosing is the USR 4-T220

The thermal resistance of the heatsink we have to use results in the following equation

$$R_{thkk} \leq (60^\circ\text{C} - 35^\circ\text{C}) / 2.5 \text{ W} = 13 \text{ K/W} = 13 \text{ K/W}$$

A heatsink with this thermal resistance is not possible.

One solution is to use a water cooled heatsink to reduce the temperature below the ambient temperature.

This solution is very expensive and in a normal application not possible.

It is better to use the resistor type UNR4-4020 TK1. The thermal resistance is 2.7 K/W. The thermal resistance of the heatsink we have to use with this resistor is $\leq 7.3 \text{ K/W}$.

ORDER NOMENCLATURE

In addition to the resistor type (i.e. UNR4-4020) the nominal resistor value, the contact and the tolerance must be mentioned .

The existing resistance values, contacts and tolerances are mentioned in the data sheets.

For the series USR and UNR it is possible to choose the option TCR. If this option is marked, we will make a selection to secure that the TCRs (25...60°C) will be in the range of $\pm 1 \text{ ppm/K}$.

For the correct order number we use the following nomenclature:

type - housing - nominal resistance value - contact - tolerance - (TCR-option)

Examples:

USR 2-0710 5K4 D 0.1%

USR 2-0710 1K D 0.01% TK1

UNR 2-1410 25R X 0.5%

UNR 4-4020 2R5 D 0.1%

FPR 2-T218 0R1 B 1%

FHR 4-3825 0R01 A 0.1%

Different thermal resistances of heatsink-mounted resistors within real applications

Relative to applications of heatsink-mounted power resistors is the question what exact power dissipation can be reached in real applications. Also it is very interesting which maximal temperatures of the resistance element appears under defined stress. If we know these results, it is possible to argument the change of the resistance through stress, the long-term stability and the failure rate.

An important factor for the answer of this question is the thermal resistance of the element against the heatsink. If we know this factor it is possible to calculate the inherent temperature of the resistance element under stress with the following equation:

$$T_{\text{resistor}} = P * R_{\text{thR}} + T_{\text{heatsink}}$$

In our data sheets the thermal resistance for all our heatsink-mounted resistors is mentioned in K/W . These data are only for a orientation. The specifications are for a pressurized assemblage and use of a heat conduction paste. Also the mentioned nominal power dissipation is related to such applications where the heatsink-temperature is 25°C or 40°C.

Herewith it is necessary to pay attention to the real heatsink-temperature. It depends from the thermal resistance of the heatsink, the total power balance (sum of all power dissipations from the parts assembled to the heatsink) and the ambient temperature.

The thermal resistance R_{thR} is the result of the thermal resistance between the resistance element and the mounting plate ($R_{\text{thj-c}}$), inherent in design, and the thermal resistance between the mounting plate and the heatsink (R_{thRAppl}), depending on the application.

The $R_{\text{thj-c}}$ is fixed from the manufacturer of the resistor. The R_{thRAppl} depends from the mounting possibilities, the size of the mounting plate, type of the fixing (i.e. number of the location holes or fixing strap), the force the resistor is assembled to the heatsink and the specialized experience of the customer for the application.

The following diagrams (picture 1 and picture 2) showing the reachable average thermal conductance (optimal application) and the absolute thermal resistance (R_{thRAppl}) dependency from the mounting place (with normal heat conduction paste).

Application note
Thermal resistance within real applications



The decrease of the heat conductivity (depending on the surface) at big mounting areas, results in the problem that it is practically not possible to reach a optimal constant pressure to fix the elements on the heatsink.

Approximated guide values for thermal paste with 1W/mK

Picture 1:

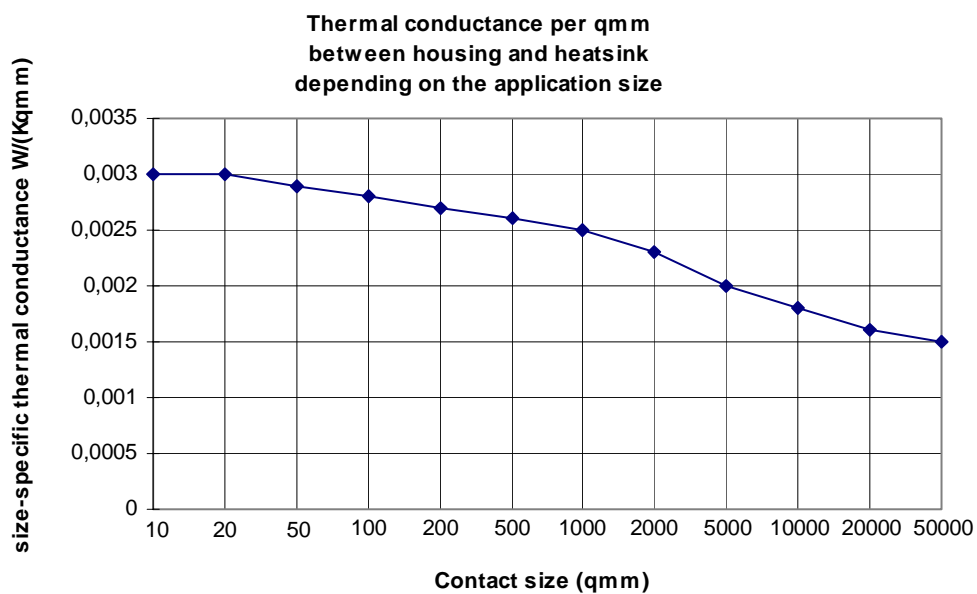

Picture 2:

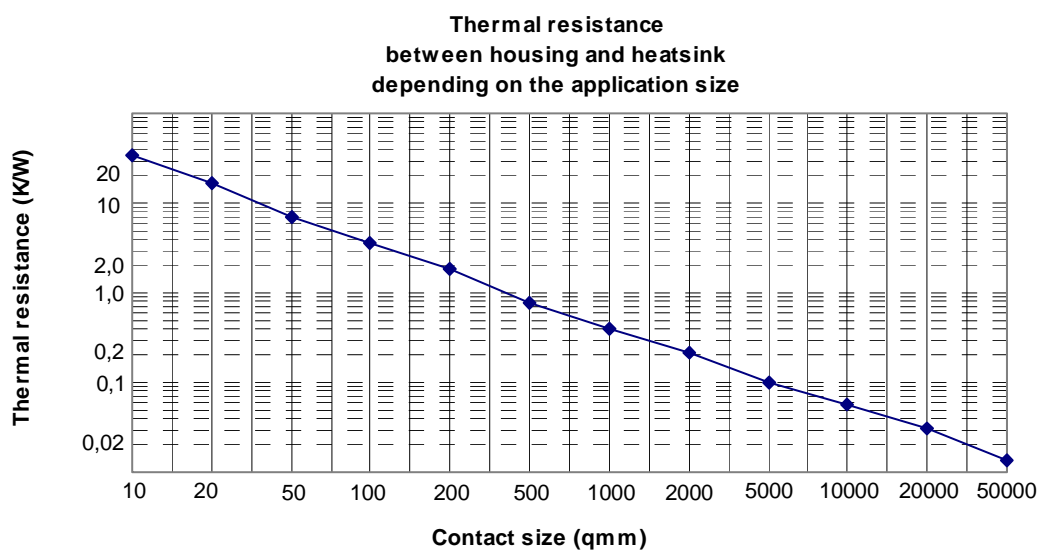

Application note

Thermal resistance within real applications



The results of these calculations are the thermal resistances between the mounting-plate and the surface of the heatsink ($R_{thRAppl}$) for the most important Powertron heatsink-mountable resistors. The specifically inherent thermal resistance of each resistor (resistance element / mounting-plate) R_{thj-c} is also mentioned.

type/size	$R_{thRAppl}$ (guide value)	R_{thj-c}
USR T220	2,2 K/W	10,8 K/W
UNR T220	2,2 K/W	6,8 K/W
USR 3425	0,5 K/W	3,5 K/W
UNR 3425	0,5 K/W	2,1 K/W
USR 4020	0,5 K/W	3,6 K/W
UNR 4020	0,5 K/W	2,2 K/W
FPR T220	1,8 K/W	4,8 K/W
FPR T218	1,0 K/W	2,5 K/W
FHR 3025	0,52 K/W	2,0 K/W
FHR 3825	0,46 K/W	1,6 K/W
FHR T238	0,42 K/W	1,3 K/W
FNR T238	0,42 K/W	1,0 K/W
FPR T227	0,2 K/W	1,3 K/W
FNR T227	0,2 K/W	1,0 K/W
FHR 8065	0,096 K/W	0,16 K/W
FHR 80110	0,060 K/W	0,09 K/W
FHR 80216	0,036 K/W	0,04 K/W
FHR 80320	0,025 K/W	0,026 K/W
FHR 80370	0,02 K/W	0,022 K/W
NPR T220 / T221	0,6 K/W	3,5 K/W
KPR T218	0,3 K/W	2,1 K/W
NHR T220 / T221	0,6 K/W	2,1 K/W
KHR T218	0,3 K/W	0,8 K/W
KPR T227	0,2 K/W	0,7 K/W
KHR T227	0,2 K/W	0,35 K/W

With these specifications it is possible to calculate the maximal allowed power dissipation. It is only necessary to define the temperature of the housing (i.e. 85°C at the mounting-plate). This temperature must be secured by the application.

$$P_{max} = (T_{limit} - T_{housing}) / R_{thj-c}$$

An additional increase of the heat dissipation can be reached with the use of a heat adhesive adgent. The disadvantage is that it is difficult to remove later the fixed resistor.

Resistor series F (CuNiMn-Foil)

Measurements	Test Condition	Max. Change
Permanency DIN IEC 115 Part 1	1000h / 70°C / 0.75 P _n 90 min / 30 min	0.05%
Permanency DIN IEC 115 Part 1	1000h / 70°C / P _n 90 min / 30 min	0.1%
Dry Heat DIN IEC 115 Part 1	16h / 130°C	0.1%
Coldness DIN IEC 115 Part 1	2h / -40°C	0.1%
Fast Temperature-cycle test DIN IEC 115 Part 1	5 Cycles -40°C / +130°C / 30 min	0.1%
Moisture resistance DIN IEC 115 Part 1	56 Tage / 40°C / 93% rh	0.05%
Resistance to soldering heat DIN IEC 115 Part 1	250°C / 5s (Method B)	0.05%
Terminal Strength DIN IEC 115 Part 1	Test condition depends on contact	0.1%

Resistor series U (NiCr-Foil)

Measurements	Test Condition	Max. Change
Permanency DIN IEC 115 Part 1	1000h / 70°C / P _n 90 min / 30 min	0.005%
Dry Heat DIN IEC 115 Part 1	16h / 130°C	0.01%
Coldness DIN IEC 115 Part 1	2h / -55°C	0.01%
Fast Temperature-cycle test DIN IEC 115 Part 1	5 Cycles -55°C / +155°C / 30 min	0.01%
Moisture resistance DIN IEC 115 Part 1	56 Days / 40°C / 93% rh	0.05%
Resistance to soldering heat DIN IEC 115 Part 1	250°C / 5s (Method B)	0.01%
Terminal Strength DIN IEC 115 Part 1	Test condition depends on contact	0.01%

Resistor series K and N (Thickfilm)

Measurements	Test Condition	Max. Change
Permanency DIN IEC 115 Part 1	2000h / 70°C / P _n 90 min / 30 min	1.0%
Short Overload DIN IEC 115 Part 1	5s / 2.5 x U _{rated} or U _{max}	0.1%
Dry Heat DIN IEC 115 Part 1	16h / 155°C	0.25%
Coldness DIN IEC 115 Part 1	2h / -55°C	0.25%
Fast Temperature-cycle test DIN IEC 115 Part 1	5 Cycles -55°C / +155°C / 30 min	0.25%
Moisture resistance DIN IEC 115 Part 1	56 Days / 40°C / 93% rh	0.25%
Resistance to soldering heat DIN IEC 115 Part 1	250°C / 5s (Method B)	0.1%
Terminal Strength DIN IEC 115 Part 1	Test condition depends on contact	0.1%