



SSL5018TE

Compact non-dimmable LED driver IC

Rev. 2 — 26 February 2014

Product data sheet

1. General description

The SSL5018TE is a high-voltage Integrated Circuit (IC) controller with an integrated MOSFET for driving LED lamps in general mains non-dimmable lighting applications. The IC operates with input voltages up to 230 V (AC).

The main benefits of these products are:

- Small Printed-Circuit Board (PCB) footprint, and compact solution
- High efficiency (up to 93 %)
- High input power factor (> 0.95); Low Total Harmonic Distortion (THD; < 20 %)
- Intermediate power factor (PF > 0.7); low ripple (< 5 %); minimum external component count
- Enhanced power capability
- Low electronic Bill Of Material (BOM)

The SSL5018TE operates in Boundary Conduction Mode (BCM) with peak current modulation, providing an input power factor correction. The IC is typically configured to a buck converter. It can start up directly from the HV pin using an internal high-voltage current source. When the converter is switching, V_{CC} is supplied through the DVDT pin by a capacitor coupled to the DRAIN pin or by an auxiliary supply. This feature simplifies the V_{CC} supply. It allows a low-cost off-the-shelf inductor to be used, providing flexibility in application design. The IC supply current is 1.3 mA.

The SSL5018TE comes in a compact HSO8 package incorporating an exposed pad to enhance the thermal capability for high-power applications, like 18 W T-LEDs or higher power lamps.

2. Features and benefits

- Driving LED strings from a rectified mains supply
- Highly integrated switch mode LED driver with integrated 600 V (DC) power switches
- Efficient BCM operation with:
 - ◆ No reverse recovery losses in freewheel diode
 - ◆ Zero Current Switching (ZCS) for turn-on of switch
 - ◆ Zero voltage or valley switching for turn-on of switch
 - ◆ Minimal required inductance value and size
- Direct PWM current regulation possible
- Fast transient response through peak current mode control:



- ◆ No overshoots or undershoots in the LED current
- Internal protections:
 - ◆ UnderVoltage LockOut (UVLO)
 - ◆ Leading-Edge Blanking (LEB)
 - ◆ OverCurrent Protection (OCP)
 - ◆ Internal OverTemperature Protection (OTP)
 - ◆ Brownout protection
 - ◆ Output Short Protection (OSP)
- Low BOM LED driver solution (see [Figure 3](#)):
 - ◆ No Schottky diode required due to ZCS
 - ◆ Option for soft-start function
 - ◆ Compatible with wall switches with built-in standby indicator lights¹
- IC lifetime meets and exceeds the required LED lamp lifetime

3. Applications

The SSL5018TE is intended for low-cost mains non-dimmable LED lighting applications, including 18 W T-LEDs or higher power lamps, with a high power factor. The IC operates from 100 V (AC) or 120 V (AC) mains voltages. The output current can be modulated using a PWM signal.

4. Quick reference data

Table 1. Quick reference data

Symbol	Parameter	Conditions	Min	Typ	Max	Unit
V _{CC}	supply voltage	operating range	[1] 8	-	15	V
R _{DSon}	drain-source on-state resistance	T _j = 25 °C	4	5	6	Ω
		T _j = 125 °C	6	7.5	9	Ω
f _{conv}	conversion frequency		-	100	-	kHz
I _{DRAIN}	current on pin DRAIN		-1.2	-	+1.2	A
V _{DRAIN}	voltage on pin DRAIN		-0.4	-	600	V

[1] An internal clamp sets the supply voltage. The current into the VCC pin must not exceed the maximum I_{DD} value (see [Table 5](#)).

5. Ordering information

Table 2. Ordering information

Type number	Package		Version
	Name	Description	
SSL5018TE	HSO8	plastic small package outline body; 8 leads; body width 3.9 mm	SOT786-3

1. The Hotaru switch is a known wall switch with built-in light

Table 3. Ordering options

Type	Input voltage	Internal MOSFET characteristics	Package
SSL5018TE	100 V; 120 V; 230 V	600 V (DC); 5 Ω	HSO8

6. Block diagram

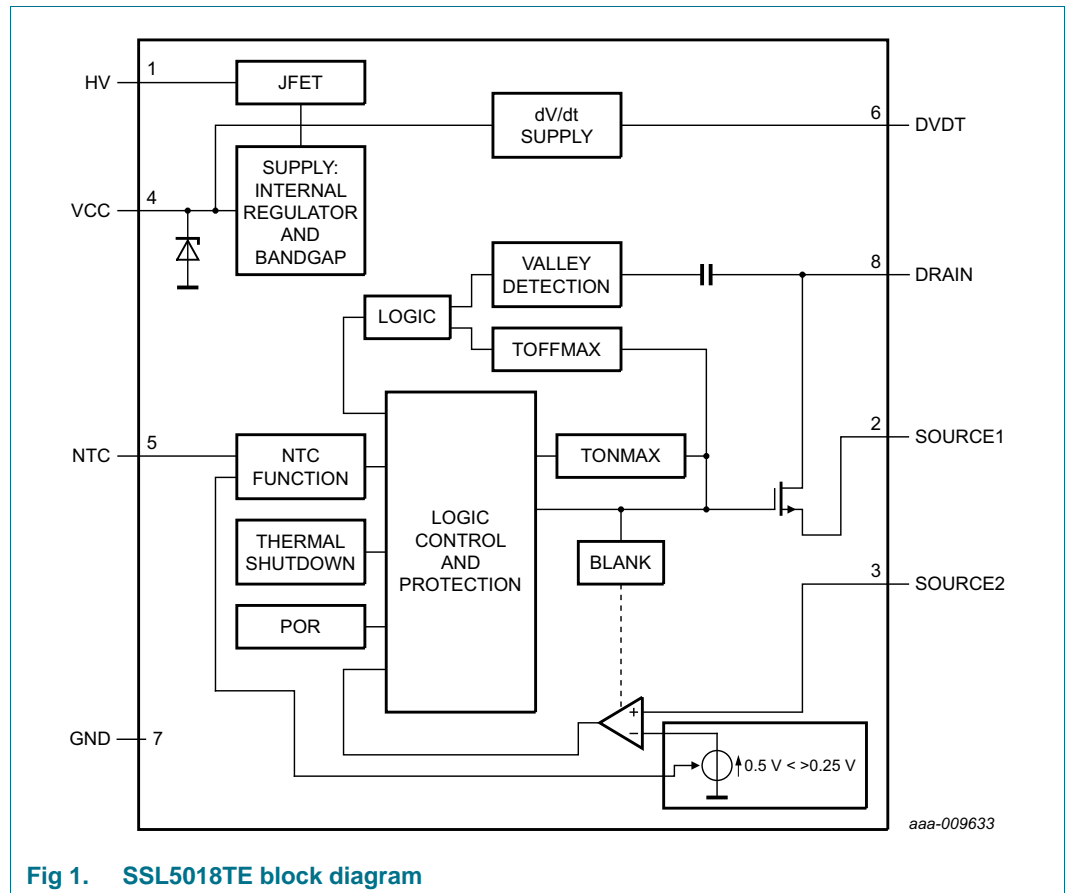

7. Pinning information

7.1 Pinning

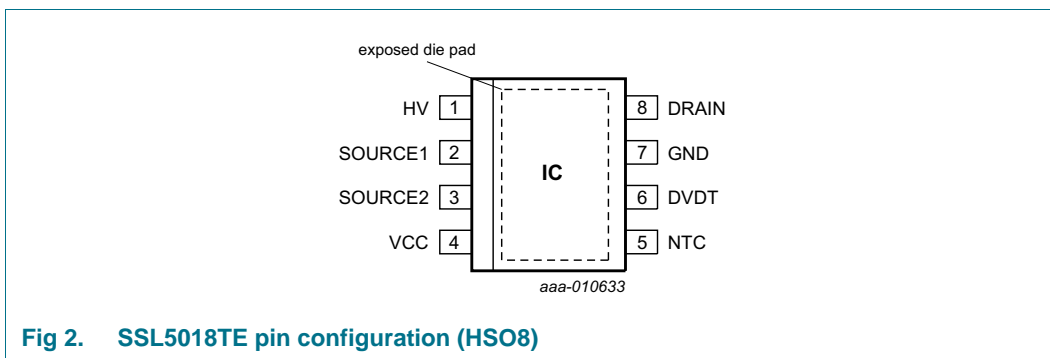

7.2 Pin description

Table 4. Pin description

Symbol	Pin (SO8)	Description
HV	1	high-voltage supply pin
SOURCE1	2	internal MOSFET source
SOURCE2	3	current sensing source
VCC	4	supply voltage
NTC	5	LED temperature protection input
DVDT	6	capacitor switching supply pin
GND	7	ground
DRAIN	8	internal MOSFET drain

8. Functional description

8.1 Converter operation

The converter in the SSL5018TE is a BCM, peak current controlled system. [Figure 3](#) shows the basic application diagram. [Figure 4](#) shows the waveforms. This converter operates at the boundary between continuous and discontinuous modes. Energy is stored in inductor L when the MOSFET is switched on. The inductor current I_L is zero when the internal MOSFET is switched on at t_0 . Thereafter, the amplitude of the current builds up in L proportionally with $V_{IN} - V_{OUT}$ and the time that the internal MOSFET is on (t_0 to t_1). The peak current sensed at the SOURCE2 pin determines when the MOSFET is switched off. When the internal MOSFET switches off at t_1 , the current flows through the freewheeling diode and the output capacitor (t_2 to t_3). The current then drops at a rate proportional to the value of V_{OUT} . When the inductor current reaches zero, after a short delay (t_3 to t_{00}), a new switching cycle is started when the MOSFET is switched on again.

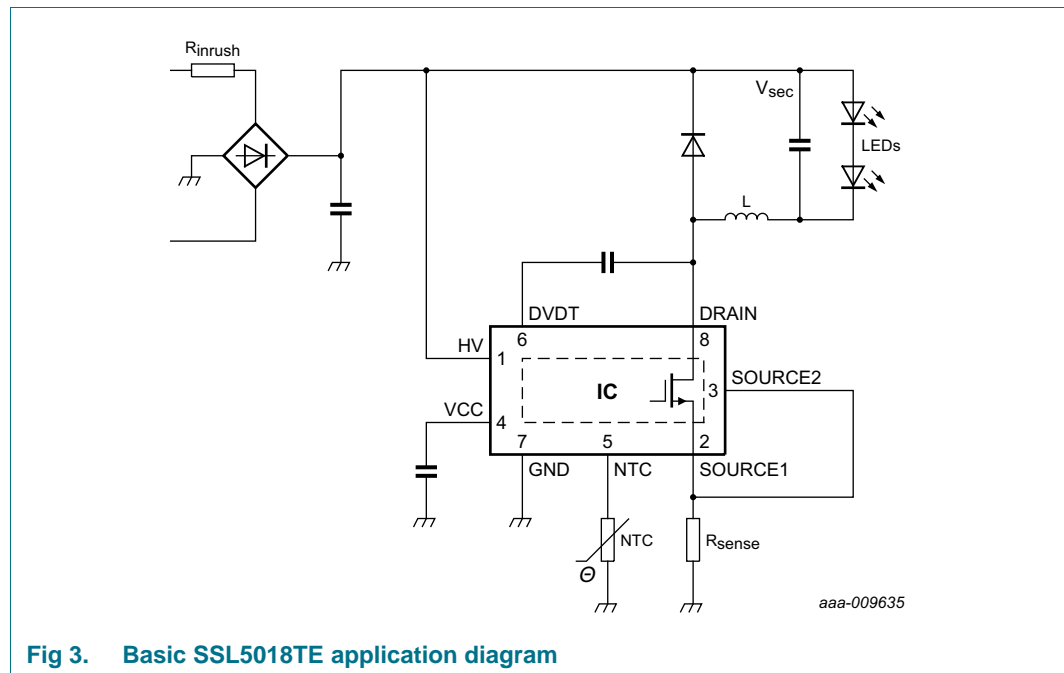

Fig 3. Basic SSL5018TE application diagram

8.2 Valley detection

After the inductor current decreases to zero at t_3 , the drain voltage starts to oscillate around the $V_{IN} - V_{OUT}$ level, with an amplitude equal to V_{OUT} . A special feature called valley detection is integrated in the SSL5018TE circuitry. The dedicated valley detection circuitry connected to the DRAIN pin senses when the voltage on the drain of the switch reaches its lowest level (valley). When the valley is detected, the switch is turned on again. The next switching cycle is started. As a result, the switch-on switching losses are reduced.

If both the frequency of the oscillations and the voltage swing are within the range specified (f_{ring} and $\Delta V_{vrec(min)}$) for detection, a valley is detected and accepted. If a valid valley is not detected, the switch is kept off until the maximum off-time ($t_{off(high)}$) is reached. Then the next switching cycle is started.

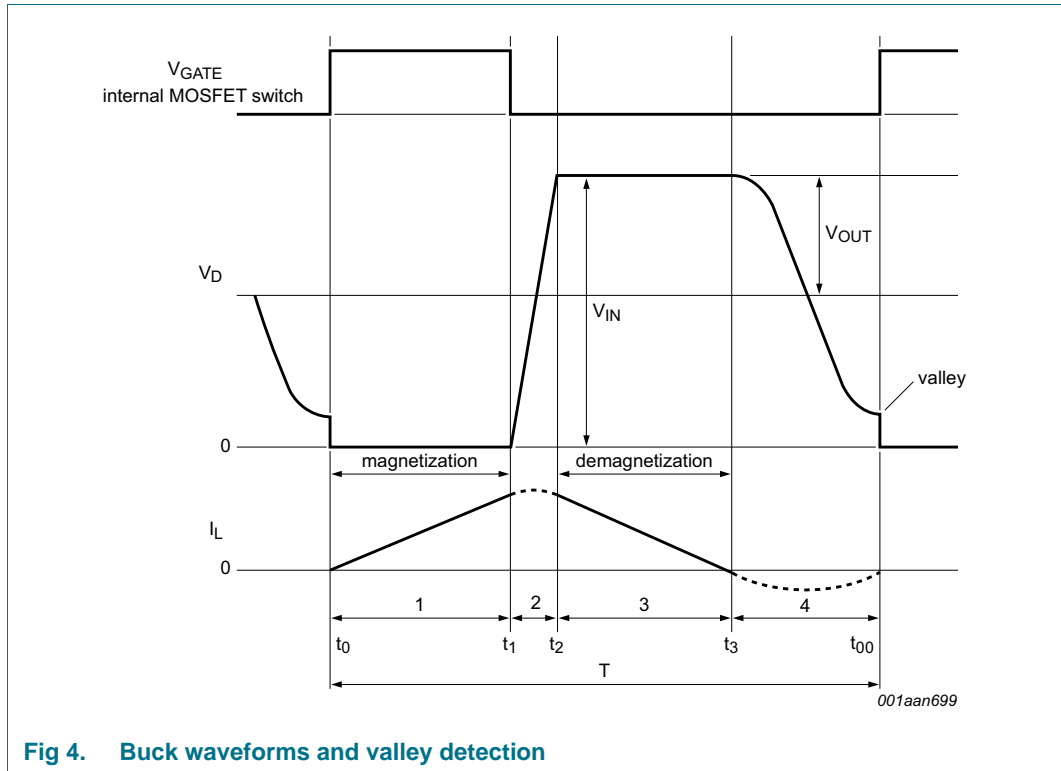

Fig 4. Buck waveforms and valley detection

8.3 Protective features

The IC has the following protective features:

- UnderVoltage LockOut (UVLO)
- Leading-Edge Blanking (LEB)
- OverCurrent Protection (OCP)
- Internal OverTemperature Protection (OTP)
- Brownout protection
- Output Short Protection (OSP)
- LED overtemperature foldback protection

OSP is a latched protection. It causes the IC to halt until a reset (a result of power cycling) is executed. When V_{CC} drops to lower than V_{CC(rst)}, the IC resets the latch protection. The internal OTP and LED overtemperature protections are safe-restart protections. The IC halts, causing V_{CC} to drop to lower than V_{CC(stop)}, instigating a start-up. When V_{CC} drops to lower than V_{CC(rst)}, the IC resets the latch protection. Switching starts only when no fault condition exists.

8.3.1 UnderVoltage LockOut (UVLO)

When the voltage on the VCC pin drops to lower than V_{CC(stop)}, the IC stops switching. When VCC drops to below V_{CC(rst)}, the IC resets. An attempt is made to restart from the HV pin when VCC > V_{CC(startup)}.

8.3.2 Leading-Edge Blanking (LEB)

To prevent false detection of the short-winding or overcurrent, a blanking time following switch-on is implemented. When the internal MOSFET switch turns on there can be a short current spike due to capacitive discharge of voltage over the drain and source. During the LEB time (t_{leb}), the spike is disregarded.

8.3.3 OverCurrent Protection (OCP)

The SSL5018TE contains a highly accurate built-in peak current detector. It triggers when the voltage at the SOURCE pin reaches the peak-level $V_{th(ocp)SOURCE}$. The current through the switch is sensed using a resistor connected to the SOURCE pin. The sense circuit is activated following LEB time (t_{leb}). As the LED current is half the peak current (by design), it automatically provides protection for maximum LED current during operation. There is a propagation delay ($t_{d(ocp-swoff)}$) between overcurrent detection and the actual MOSFET switch-off. Due to the delay, the actual peak current is slightly higher than the OCP level set by the resistor in series with the SOURCE pin.

8.3.4 OverTemperature Protection (OTP)

When the internal OTP function is triggered at a certain IC temperature ($T_{th(act)otp}$), the converter stops operating. The safe-restart protection is triggered and the IC restarts with switching resuming when the IC temperature drops to lower than $T_{th(rel)otp}$.

8.3.5 Brownout protection

Brownout protection is designed to limit the lamp power when the input voltage drops close to the output voltage level. The input power has to remain constant. The input current would otherwise increase to a level that is too high for the input circuitry. For the SSL5018TE, there is a maximum limit on the on-time $t_{on(high)}$. The rate of current rise in the coil during the on-phase is proportional to the difference between input voltage and output voltage. Therefore, the peak current cannot be reached before $t_{on(high)}$. As a result the average output current to the LEDs is reduced.

8.3.6 Output Short Protection (OSP)

During the switch-off time, if a valley is not detected within the maximum off-time limit ($t_{off(high)}$), the output voltage is less than the minimum limit allowed in the application. This condition can occur either during start-up or due to a short-circuit. A timer is started when $t_{off(high)}$ is detected, and is stopped only if a valid valley-detection occurs in one of the subsequent cycles. The timer can also be reset if the maximum limit on the on-time of the switch ($t_{on(high)}$) is reached, which is usually the case at start-up (brownout protection). The timer can also be reset if the maximum limit on the on-time of the switch ($t_{on(high)}$) is reached, which is usually the case at start-up (brownout protection).

If no valley is detected and $t_{on(high)}$ is not reached before $t_{det(sc)}$, then it is concluded that a real short-circuit exists. The IC enters latched protection. If V_{CC} drops to lower than $V_{CC(rst)}$, the IC resets the latched protection. During PWM current regulation, the OSP timer is paused during the off-cycle of the PWM signal.

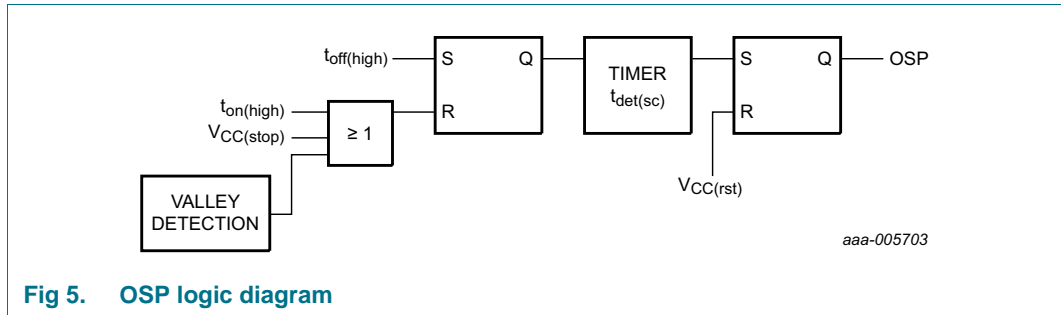

Fig 5. OSP logic diagram

8.4 VCC supply

The SSL5018TE is supplied in three ways:

- Under normal operation, the voltage swing on the DVDT pin is rectified within the IC supplying current to the VCC pin
- At start-up, there is an internal current source connected to the HV pin. The current source provides internal power until either the dV/dt supply or an external current on the VCC pin can provide the supply
- An auxiliary winding on the output inductor can be used to provide the supply; connect and rectify the voltage to the VCC pin using a series resistor.

The IC starts up when the voltage at the VCC pin is higher than $V_{CC(startup)}$. The IC locks out (stops switching) when the voltage at the VCC pin is lower than $V_{CC(stop)}$. The hysteresis between the start and stop levels allows the IC to be supplied by a buffer capacitor until the dV/dt supply is settled. The SSL5018TE has an internal V_{CC} clamp, which is an internal active Zener (or shunt regulator). It limits the voltage on the VCC supply pin to the maximum value of V_{CC} . If the maximum current of the dV/dt supply minus the current consumption of the IC (determined by the load on the gate drivers) is lower than the maximum value of I_{DD} , no external Zener diode is required in the dV/dt supply circuit.

8.5 DVDT pin supply (dV/dt)

The DVDT pin is connected to an internal single-sided rectification stage. When a different voltage with sufficient amplitude is supplied to the pin, the IC can be powered without any other external power connection. This solution provides an effective method of preventing additional high power losses, which occur when a regulator is used to power the IC continuously. Unlike an auxiliary supply, additional inductor windings are not required.

8.6 VCC regulator

During supply dips, the input voltage can drop so much that it can no longer supply the required IC current through the DVDT pin. Under these conditions, if the VCC voltage drops to lower than $V_{CC(swon)reg}$, another regulator with a current capability of up to $I_{sup(high)HV}$ is started. This regulator provides the required additional supply current, which the dV/dt supply is unable to deliver, thus preventing that the IC enters UVLO. When the VCC voltage exceeds $V_{CC(swon)reg}$ level, the regulator is switched off.

8.7 NTC function and PWM current regulation

The NTC pin can be used as a control method for LED thermal protection. Alternatively, the pin can be used as an input to disable/enable light output using a digital signal (PWM current regulation). The pin has an internal current source that generates the $I_{offset(NTC)}$ current. To monitor the LED temperature, an NTC resistor can be connected directly to the NTC pin. Depending on the resistance value and the corresponding voltage on the NTC pin, the converter reacts as shown in [Figure 6](#).

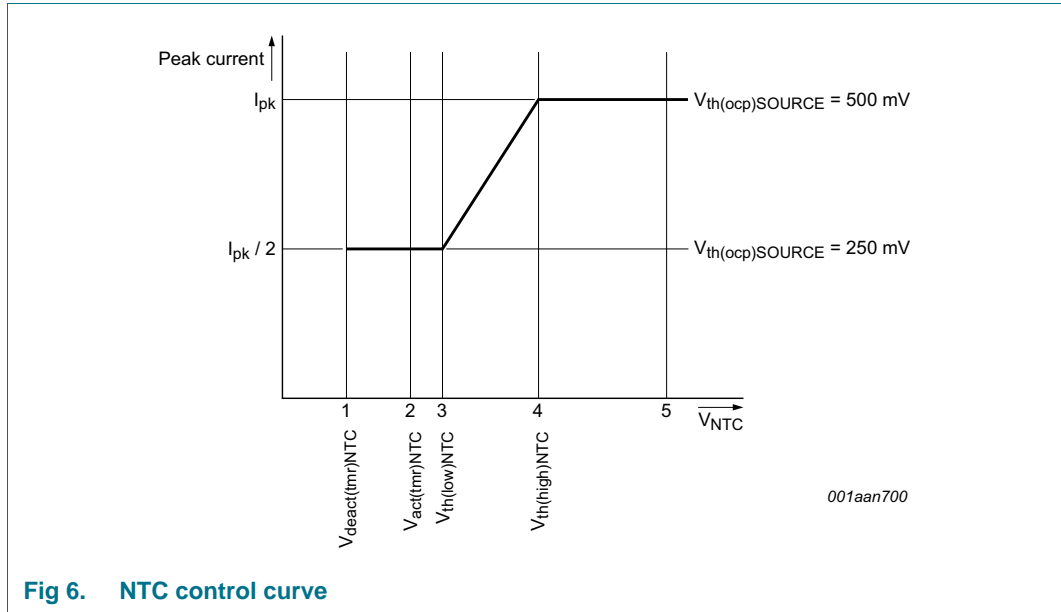

Fig 6. NTC control curve

When the voltage on the NTC pin exceeds $V_{th(high)NTC}$ (see [Figure 6 \(4\)](#)), the converter delivers nominal output current. When the voltage is lower than this level, the peak current is gradually reduced until $V_{th(low)NTC}$ is reached (see [Figure 6 \(3\)](#)). The peak current is now half the peak current of nominal operation. When $V_{act(tmr)NTC}$ is passed (see [Figure 6 \(2\)](#)), a timer starts to run to distinguish between the following situations:

- If the low-level $V_{deact(tmr)NTC}$ is not reached within time $t_{to(deact)NTC}$ (see [Figure 6 \(1\)](#)), LED overtemperature is detected. The IC stops switching and attempts to restart from the HV pin voltage. Restart takes place when the voltage on the NTC pin is higher than $V_{th(low)NTC}$ (see [Figure 6 \(4\)](#)). It is assumed that the reduction in peak current does not result in a lower NTC temperature and LED OTP is activated.
- If the low-level $V_{deact(tmr)NTC}$ is reached within the time $t_{to(deact)NTC}$ (see [Figure 6 \(1\)](#)), it is assumed that the pin is pulled down externally. The internal current source $I_{offset(NTC)}$ is switched off in this mode. The restart function is not triggered. Instead, the output current is reduced to zero. PWM current regulation can be implemented this way. The output current rises again when the voltage applied on the NTC pin is higher than $V_{th(low)NTC}$.

A PTC resistor, connected between the VCC pin and the NTC pin, in series with a resistor connected from the NTC pin to ground, can be used for thermal protection. In this situation, the voltage on the NTC pin must be less than the minimum value of $V_{act(tmr)NTC}$ before the voltage on the VCC pin reaches $V_{CC(startup)}$ during start-up.

8.8 Heat sink

The copper of the PCB acts as the heat sink for SSL5018TE applications.

[Equation 1](#) shows the relationship between the maximum allowable power dissipation P and the thermal resistance from junction to ambient.

$$R_{th(j-a)} = (T_{j(max)} - T_{amb}) / P \quad (1)$$

Where:

$R_{th(j-a)}$ = thermal resistance from junction to ambient

$T_{j(max)}$ = maximum junction temperature

T_{amb} = ambient temperature

P = power dissipation

9. Limiting values

Table 5. Limiting values

In accordance with the Absolute Maximum Rating System (IEC 60134).

Symbol	Parameter	Conditions	Min	Max	Unit
General					
SR	slew rate	on pin DRAIN	-5	+5	V/ns
P _{tot}	total power dissipation		-	1.6	W
T _{amb}	ambient temperature		-40	+125	°C
T _j	junction temperature		-40	+150	°C
T _{stg}	storage temperature		-55	+150	°C
Voltages					
V _{CC}	supply voltage	continuous	[1] -0.4	+19	V
V _{DRAIN}	voltage on pin DRAIN		-0.4	+600	V
V _{HV}	voltage on pin HV	current limited	-0.4	+600	V
V _{SOURCE}	voltage on pin SOURCE	current limited	-0.4	+5.2	V
V _{NTC}	voltage on pin NTC	current limited	-0.4	+5.2	V
Currents					
I _{DD}	supply current	at pin VCC	[2] -	20	mA
I _{DRAIN}	current on pin DRAIN		-1.2	+1.2	A
I _{SOURCE}	current on pin SOURCE		-1.2	+1.2	A
I _{DVDT}	current on pin DVDT	duration 20 μs maximum	-	1.3	A
V _{ESD}	electrostatic discharge voltage	human body model; (for all pins except DRAIN and HV)	[3] -2	+2	kV
		human body model for DRAIN and HV	-1	+1	kV
		charged device	[4] -500	+500	V

[1] The current into the VCC pin must not exceed the maximum I_{DD} value.

[2] An internal clamp sets the supply voltage and current limits.

[3] Human body model: equivalent to discharging a 100 pF capacitor through a 1.5 kΩ series resistor.

[4] Charged device model: equivalent to charging the IC up to 1 kV and the subsequent discharging of each pin down to 0 V over a 1 Ω resistor.

10. Thermal characteristics

Table 6. Thermal characteristics

Symbol	Parameter	Conditions	Typ	Unit
R _{th(j-a)}	thermal resistance from junction to ambient	in free air; HSO8 package, PCB: 1.5 cm × 14 cm, 2-layer, 35 μm copper (Cu) per layer; copper for IC: 12.7 cm ²	78	K/W
		in free air; HSO8 package; PCB: JEDEC 2s2p	41.8	K/W
Ψ _{j-top}	thermal characterization parameter from junction to top of package	top package temperature measured at the warmest point on top of the case; HSO8 package	5.14	K/W

11. Characteristics

Table 7. Characteristics

Symbol	Parameter	Conditions	Min	Typ	Max	Unit
f_{conv}	conversion frequency		-	100	-	kHz
High-voltage						
$I_{\text{leak(DRAIN)}}$	leakage current on pin DRAIN	$V_{\text{DRAIN}} = 600 \text{ V (DC)}$	-	-	10	μA
$I_{\text{leak(HV)}}$	leakage current on pin HV	$V_{\text{HV}} = 600 \text{ V (DC)}$	-	-	30	μA
Supply						
V_{CC}	supply voltage	operating range	[1] 8	-	15	V
$V_{\text{CC(startup)}}$	start-up supply voltage		11	12	13	V
$V_{\text{CC(stop)}}$	stop supply voltage		8	9	10	V
$V_{\text{CC(hys)}}$	hysteresis of supply voltage	between $V_{\text{CC(startup)}}$ and $V_{\text{CC(stop)}}$	2	-	-	V
$V_{\text{CC(rst)}}$	reset supply voltage		4.5	5	5.5	V
$V_{\text{CC(swon)reg}}$	regulator switch-on supply voltage	insufficient dV/dt supply	8.75	9.25	9.75	V
$V_{\text{CC(swoff)reg}}$	regulator switch-off supply voltage	insufficient dV/dt supply	9.5	10	10.5	V
$V_{\text{CC(reg)hys}}$	regulator supply voltage hysteresis	$V_{\text{CC(swoff)reg}} - V_{\text{CC(swon)reg}}$	0.3	-	-	V
$V_{\text{CC(regswon-stop)}}$	supply voltage difference between regulator switch-on and stop	$V_{\text{CC(swon)reg}} - V_{\text{CC(stop)}}$	0.3	-	-	V
Consumption						
$I_{\text{stb(HV)}}$	standby current on pin HV	during start-up or in protection; $V_{\text{HV}} = 100 \text{ V}$	300	350	400	μA
I_{CC}	supply current	normal operation	-	1.3	-	mA
Capability						
$I_{\text{sup(high)HV}}$	high supply current on pin HV	Standby: $V_{\text{HV}} = 40 \text{ V};$ $V_{\text{CC}} < V_{\text{CC(stop)}}$	1	1.3	1.6	mA
		Regulator On: $V_{\text{HV}} = 40 \text{ V};$ $V_{\text{CC}} < V_{\text{CC(swon)reg}}$ after start-up	2	2.3	2.6	mA
Current and SWP						
$V_{\text{th(ocp)SOURCE2}}$	overcurrent protection threshold voltage on pin SOURCE2	$\Delta V/\Delta t = 0.1 \text{ V}/\mu\text{s}$	480	500	520	mV
		$\Delta V/\Delta t = 0.1 \text{ V}/\mu\text{s}; V_{\text{NTC}} = 0.325 \text{ V}$	230	250	270	mV
$t_{\text{d(ocp-swoff)}}$	delay time from overcurrent protection to switch-off	$\Delta V/\Delta t = 0.1 \text{ V}/\mu\text{s}$	-	75	100	ns
t_{leb}	leading edge blanking time	overcurrent protection	260	300	340	ns
Valley detection						
$(\Delta V/\Delta t)_{\text{vrec}}$	valley recognition voltage change with time	on pin DRAIN	-30	-20	-10	V/ μs
f_{ring}	ringing frequency		[2] 200	550	1000	kHz
$\Delta V_{\text{vrec(min)}}$	minimum valley recognition voltage difference	voltage drop on pin DRAIN	15	20	25	V
$t_{\text{d(vrec-swon)}}$	valley recognition to switch-on delay time		-	100	-	ns

Table 7. Characteristics ...continued

Symbol	Parameter	Conditions	Min	Typ	Max	Unit
Brownout detection						
$t_{on(high)}$	high on-time		12.5	15	17.5	μs
MOSFET output stage						
$V_{BR(DRAIN)}$	breakdown voltage on pin DRAIN	$T_j > 0\text{ }^\circ C$	600	-	-	V
R_{DSon}	drain-source on-state resistance	$T_j = 25\text{ }^\circ C$	4	5	6	Ω
		$T_j = 125\text{ }^\circ C$	6	7.5	9	Ω
$(dV/dt)_{f(DRAIN)}$	fall rate of change of voltage on pin DRAIN	$C_{DRAIN} = 75\text{ pF}; R_{SOURCE} = 1.2\text{ }\Omega$	-	1.5	-	V/ns
NTC function						
$V_{th(high)NTC}$	high threshold voltage on pin NTC		0.47	0.5	0.53	V
$V_{th(low)NTC}$	low threshold voltage on pin NTC		0.325	0.35	0.375	V
$V_{act(tmr)NTC}$	timer activation voltage on pin NTC		0.26	0.29	0.325	V
$V_{deact(tmr)NTC}$	timer deactivation voltage on pin NTC		0.17	0.2	0.23	V
$t_{to(deact)NTC}$	deactivation time-out time on pin NTC		33	46	59	μs
$I_{offset(NTC)}$	offset current on pin NTC		-	-47	-	μA
OSP						
$t_{det(sc)}$	short-circuit detection time		16	20	24	ms
$t_{off(high)}$	high off-time		30	36	42	μs
Temperature protections						
$T_{th(act)otp}$	overtemperature protection activation threshold temperature		160	170	180	$^\circ C$
$T_{th(rel)otp}$	overtemperature protection release threshold temperature		90	100	110	$^\circ C$

[1] An internal clamp sets the supply voltage. The current into the VCC pin must not exceed the maximum IDD value (see [Table 5](#)).

[2] This parameter is not tested during production, by design it is guaranteed.

13. Package outline

HSO8: plastic thermal enhanced small outline package;
8 leads; body width 3.9 mm; exposed die pad

SOT786-3

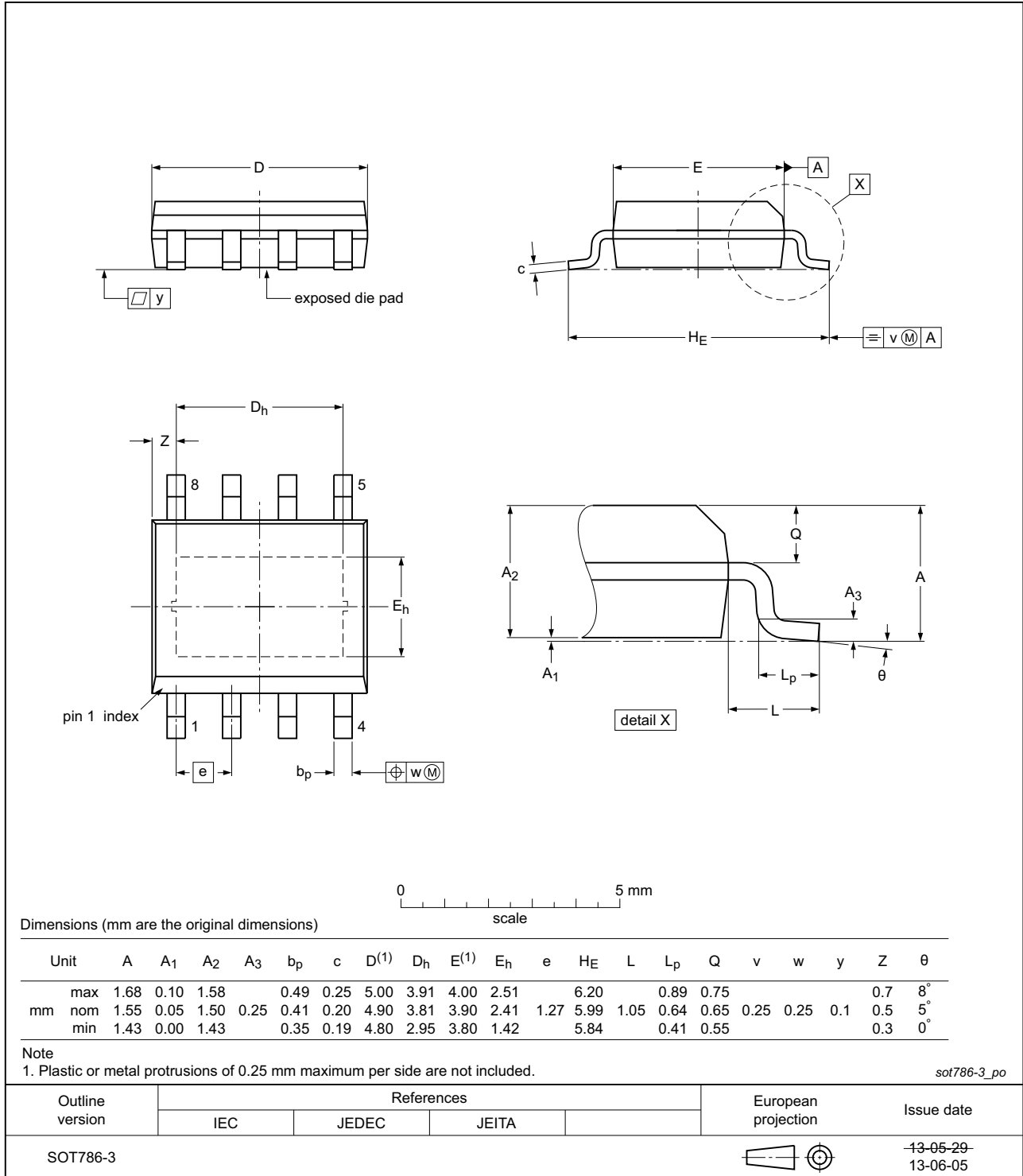

Fig 8. Package outline SOT786-3 (HSO8)

14. Abbreviations

Table 8. Abbreviations

Acronym	Description
BCM	Boundary Conduction Mode
BOM	Bill Of Materials
LED	Light Emitting Diode
LEB	Leading-Edge Blanking
MOSFET	Metal-Oxide Semiconductor Field-Effect Transistor
OCP	OverCurrent Protection
OSP	Output Short Protection
OTP	OverTemperature Protection
PCB	Printed-Circuit Board
PWM	Pulse-Width Modulation
UVLO	UnderVoltage LockOut
ZCS	Zero Current Switching

15. References

- [1] **AN11041** — SSL21081, SSL21083, and SSL2109 non-dimmable buck converter in low ripple configurations

16. Revision history

Table 9. Revision history

Document ID	Release date	Data sheet status	Change notice	Supersedes
SSL5018TE v.2	20140226	Product data sheet	-	SSL5018TE v.1
Modifications:	• The data sheet status has changed from Preliminary to Product.			
SSL5018TE v.1	20140129	Preliminary data sheet	-	-

17. Legal information

17.1 Data sheet status

Document status ^{[1][2]}	Product status ^[3]	Definition
Objective [short] data sheet	Development	This document contains data from the objective specification for product development.
Preliminary [short] data sheet	Qualification	This document contains data from the preliminary specification.
Product [short] data sheet	Production	This document contains the product specification.

[1] Please consult the most recently issued document before initiating or completing a design.

[2] The term 'short data sheet' is explained in section "Definitions".

[3] The product status of device(s) described in this document may have changed since this document was published and may differ in case of multiple devices. The latest product status information is available on the Internet at URL <http://www.nxp.com>.

17.2 Definitions

Draft — The document is a draft version only. The content is still under internal review and subject to formal approval, which may result in modifications or additions. NXP Semiconductors does not give any representations or warranties as to the accuracy or completeness of information included herein and shall have no liability for the consequences of use of such information.

Short data sheet — A short data sheet is an extract from a full data sheet with the same product type number(s) and title. A short data sheet is intended for quick reference only and should not be relied upon to contain detailed and full information. For detailed and full information see the relevant full data sheet, which is available on request via the local NXP Semiconductors sales office. In case of any inconsistency or conflict with the short data sheet, the full data sheet shall prevail.

Product specification — The information and data provided in a Product data sheet shall define the specification of the product as agreed between NXP Semiconductors and its customer, unless NXP Semiconductors and customer have explicitly agreed otherwise in writing. In no event however, shall an agreement be valid in which the NXP Semiconductors product is deemed to offer functions and qualities beyond those described in the Product data sheet.

17.3 Disclaimers

Limited warranty and liability — Information in this document is believed to be accurate and reliable. However, NXP Semiconductors does not give any representations or warranties, expressed or implied, as to the accuracy or completeness of such information and shall have no liability for the consequences of use of such information. NXP Semiconductors takes no responsibility for the content in this document if provided by an information source outside of NXP Semiconductors.

In no event shall NXP Semiconductors be liable for any indirect, incidental, punitive, special or consequential damages (including - without limitation - lost profits, lost savings, business interruption, costs related to the removal or replacement of any products or rework charges) whether or not such damages are based on tort (including negligence), warranty, breach of contract or any other legal theory.

Notwithstanding any damages that customer might incur for any reason whatsoever, NXP Semiconductors' aggregate and cumulative liability towards customer for the products described herein shall be limited in accordance with the *Terms and conditions of commercial sale* of NXP Semiconductors.

Right to make changes — NXP Semiconductors reserves the right to make changes to information published in this document, including without limitation specifications and product descriptions, at any time and without notice. This document supersedes and replaces all information supplied prior to the publication hereof.

Suitability for use — NXP Semiconductors products are not designed, authorized or warranted to be suitable for use in life support, life-critical or safety-critical systems or equipment, nor in applications where failure or malfunction of an NXP Semiconductors product can reasonably be expected to result in personal injury, death or severe property or environmental damage. NXP Semiconductors and its suppliers accept no liability for inclusion and/or use of NXP Semiconductors products in such equipment or applications and therefore such inclusion and/or use is at the customer's own risk.

Applications — Applications that are described herein for any of these products are for illustrative purposes only. NXP Semiconductors makes no representation or warranty that such applications will be suitable for the specified use without further testing or modification.

Customers are responsible for the design and operation of their applications and products using NXP Semiconductors products, and NXP Semiconductors accepts no liability for any assistance with applications or customer product design. It is customer's sole responsibility to determine whether the NXP Semiconductors product is suitable and fit for the customer's applications and products planned, as well as for the planned application and use of customer's third party customer(s). Customers should provide appropriate design and operating safeguards to minimize the risks associated with their applications and products.

NXP Semiconductors does not accept any liability related to any default, damage, costs or problem which is based on any weakness or default in the customer's applications or products, or the application or use by customer's third party customer(s). Customer is responsible for doing all necessary testing for the customer's applications and products using NXP Semiconductors products in order to avoid a default of the applications and the products or of the application or use by customer's third party customer(s). NXP does not accept any liability in this respect.

Limiting values — Stress above one or more limiting values (as defined in the Absolute Maximum Ratings System of IEC 60134) will cause permanent damage to the device. Limiting values are stress ratings only and (proper) operation of the device at these or any other conditions above those given in the Recommended operating conditions section (if present) or the Characteristics sections of this document is not warranted. Constant or repeated exposure to limiting values will permanently and irreversibly affect the quality and reliability of the device.

Terms and conditions of commercial sale — NXP Semiconductors products are sold subject to the general terms and conditions of commercial sale, as published at <http://www.nxp.com/profile/terms>, unless otherwise agreed in a valid written individual agreement. In case an individual agreement is concluded only the terms and conditions of the respective agreement shall apply. NXP Semiconductors hereby expressly objects to applying the customer's general terms and conditions with regard to the purchase of NXP Semiconductors products by customer.

No offer to sell or license — Nothing in this document may be interpreted or construed as an offer to sell products that is open for acceptance or the grant, conveyance or implication of any license under any copyrights, patents or other industrial or intellectual property rights.

Export control — This document as well as the item(s) described herein may be subject to export control regulations. Export might require a prior authorization from competent authorities.

Quick reference data — The Quick reference data is an extract of the product data given in the Limiting values and Characteristics sections of this document, and as such is not complete, exhaustive or legally binding.

Non-automotive qualified products — Unless this data sheet expressly states that this specific NXP Semiconductors product is automotive qualified, the product is not suitable for automotive use. It is neither qualified nor tested in accordance with automotive testing or application requirements. NXP Semiconductors accepts no liability for inclusion and/or use of non-automotive qualified products in automotive equipment or applications.

In the event that customer uses the product for design-in and use in automotive applications to automotive specifications and standards, customer (a) shall use the product without NXP Semiconductors' warranty of the product for such automotive applications, use and specifications, and (b)

whenever customer uses the product for automotive applications beyond NXP Semiconductors' specifications such use shall be solely at customer's own risk, and (c) customer fully indemnifies NXP Semiconductors for any liability, damages or failed product claims resulting from customer design and use of the product for automotive applications beyond NXP Semiconductors' standard warranty and NXP Semiconductors' product specifications.

Translations — A non-English (translated) version of a document is for reference only. The English version shall prevail in case of any discrepancy between the translated and English versions.

17.4 Trademarks

Notice: All referenced brands, product names, service names and trademarks are the property of their respective owners.

GreenChip — is a trademark of NXP N.V.

18. Contact information

For more information, please visit: <http://www.nxp.com>

For sales office addresses, please send an email to: salesaddresses@nxp.com

19. Contents

1 General description 1

2 Features and benefits 1

3 Applications 2

4 Quick reference data 2

5 Ordering information 2

6 Block diagram 3

7 Pinning information 4

7.1 Pinning 4

7.2 Pin description 4

8 Functional description 5

8.1 Converter operation 5

8.2 Valley detection. 5

8.3 Protective features 6

8.3.1 UnderVoltage LockOut (UVLO) 6

8.3.2 Leading-Edge Blanking (LEB) 7

8.3.3 OverCurrent Protection (OCP) 7

8.3.4 OverTemperature Protection (OTP) 7

8.3.5 Brownout protection 7

8.3.6 Output Short Protection (OSP) 7

8.4 VCC supply. 8

8.5 DVDT pin supply (dV/dt) 8

8.6 VCC regulator. 8

8.7 NTC function and PWM current regulation. 9

8.8 Heat sink. 10

9 Limiting values. 11

10 Thermal characteristics 11

11 Characteristics. 12

12 SSL5018TE buck configuration 14

13 Package outline 15

14 Abbreviations. 16

15 References 16

16 Revision history. 17

17 Legal information. 18

17.1 Data sheet status 18

17.2 Definitions. 18

17.3 Disclaimers. 18

17.4 Trademarks. 19

18 Contact information. 19

19 Contents 20

Please be aware that important notices concerning this document and the product(s) described herein, have been included in section 'Legal information'.