



MOSCHIP
SEMICONDUCTOR

MCS9900

PCIe to Multi IO Controller

Preliminary Datasheet

Rev 1.5

July, 2010

Revision History

Revision	Reason for change	Date
1.0	Initial release	
1.1	Table of contents updated	16 th September 2009
1.2	Block Diagram updated, 650 Mode support added under Serial Port features list	25 th September 2009
1.3	Document updated for aesthetical changes	26 th October 2009
1.4	Document updated for changes in derivative product ID changes (i.e 9912 to 9901CV-CC)	07 th January 2010
1.5	Description of Ground Pins updated in Table 3.12. Description of few cascade pins also updated in Table 3.5.	26 th July 2010

Published by :

MosChip Semiconductor; 3335 Kifer Road ; Santa Clara, California 95051, U.S.A

Phone: 408.737.7141; Website: www.moschip.com

MosChip Semiconductor Technology, LTD products are not authorized for use as critical components in life support devices or systems. Life support devices are applications that may involve potential risks of death, personal injury or severe property or environmental damages. These critical components are semiconductor products whose failure to perform can be reasonably expected to cause the failure of the life support systems or device, or to adversely impact its effectiveness or safety.

The use of MosChip Semiconductor Technology LTD's products in such devices or systems is done so fully at the customer risk and liability. As in all designs and applications it is recommended that the customer apply sufficient safeguards and guard bands in both the design and operating parameters. MosChip Semiconductor Technology LTD assumes No liability for customer's applications assistance or for any customer's product design(s) that use MosChip Semiconductor Technology, LTD's products.

MosChip Semiconductor Technology, LTD warrants the performance of its products to the current Specifications in effect at the time of sale per MosChip Semiconductor Technology, LTD standard limited warranty. MosChip Semiconductor Technology, LTD imposes testing and quality control processes that it deems necessary to support this warranty. The customer should be aware that not all parameters are 100% tested for each device. Sufficient testing is done to ensure product reliability in accordance with MosChip Semiconductor Technology LTD's warranty. MosChip Semiconductor Technology, LTD believes the information in this document to be accurate and reliable but assumes no responsibility for any errors or omissions that may have occurred in its generation or printing. The information contained herein is subject to change without notice and no responsibility is assumed by MosChip Semiconductor Technology, LTD to update or keep current the information contained in this document, nor for its use or for infringement of patent or other rights of third parties. MosChip Semiconductor Technology, LTD does NOT warrant or represent that any license, either expressed or implied, is granted to the user.

Copyright © 2010 MosChip Semiconductor Technology Limited

Table of Contents

1	Introduction	4
1.1	Block Diagram	4
1.2	Features	5
1.3	Applications	6
1.4	Ordering information.....	6
1.5	Support	6
1.6	Package options.....	7
2	Pin Diagrams	8
2.1	MCS9900CV-AA Pin Diagram	8
2.2	MCS9904CV-AA Pin diagram	9
2.3	MCS9901CV-CC Pin diagram.....	10
2.4	MCS9922CV-AA Pin diagram	11
3	Pin Description	12
3.1	Pin configurations.....	12
3.2	PCI Express Interface Signals	15
3.3	Serial Port Interface Signals.....	16
3.4	Parallel port Interface signals	18
3.5	Cascade Interface Signals	20
3.6	I ² C Interface Signals	22
3.7	GPIO Interface Signals	22
3.8	Clock/Crystal Oscillator Interface Signals	22
3.9	Mode Select Signals.....	22
3.10	Test Mode Signals.....	22
3.11	JTAG Interface Signals.....	23
3.12	Power Supply Signals	23
4	Mode Selection and Function Mapping.....	25
5	Functional Description	26
5.1	PCIe Operation.....	26
5.2	PCIe Configuration Space	28
5.3	Serial Port	32
5.4	Parallel Port	33
5.5	I ² C.....	36
5.6	PM Control.....	37
5.7	Cascade Interface	38
5.8	Clocks and Resets	40
5.9	GPIO.....	41
6	EEPROM Contents Layout.....	42
7	Electrical Specifications.....	46
8	Mechanical Dimensions	48

1 Introduction

MCS9900 is a single lane multifunction PCI express to I/O controller. It supports two modes of operations which are selectable through device mode select pins. Mode1 supports four serial ports and GPIO, Mode2 supports two serial ports, one parallel port and GPIO. MCS9900 also provides an option for peripheral expansion through MosChip proprietary Cascade interface. The generic cascade interface allows interconnecting with similar chips like MCS9900, MCS9950 to expand the peripheral ports. The serial ports are compatible with RS232, RS422 & RS485 standards and supports throughput from 50bps to 16Mbps. Parallel Port is compatible with IEEE 1284 and supports Nibble, Byte, SPP, ECP, and EPP modes. All the GPIO pins are programmable and can be used as Input or Output. An I²C interface is provided to configure MCS9900 device options through an external EEPROM.

1.1 Block Diagram

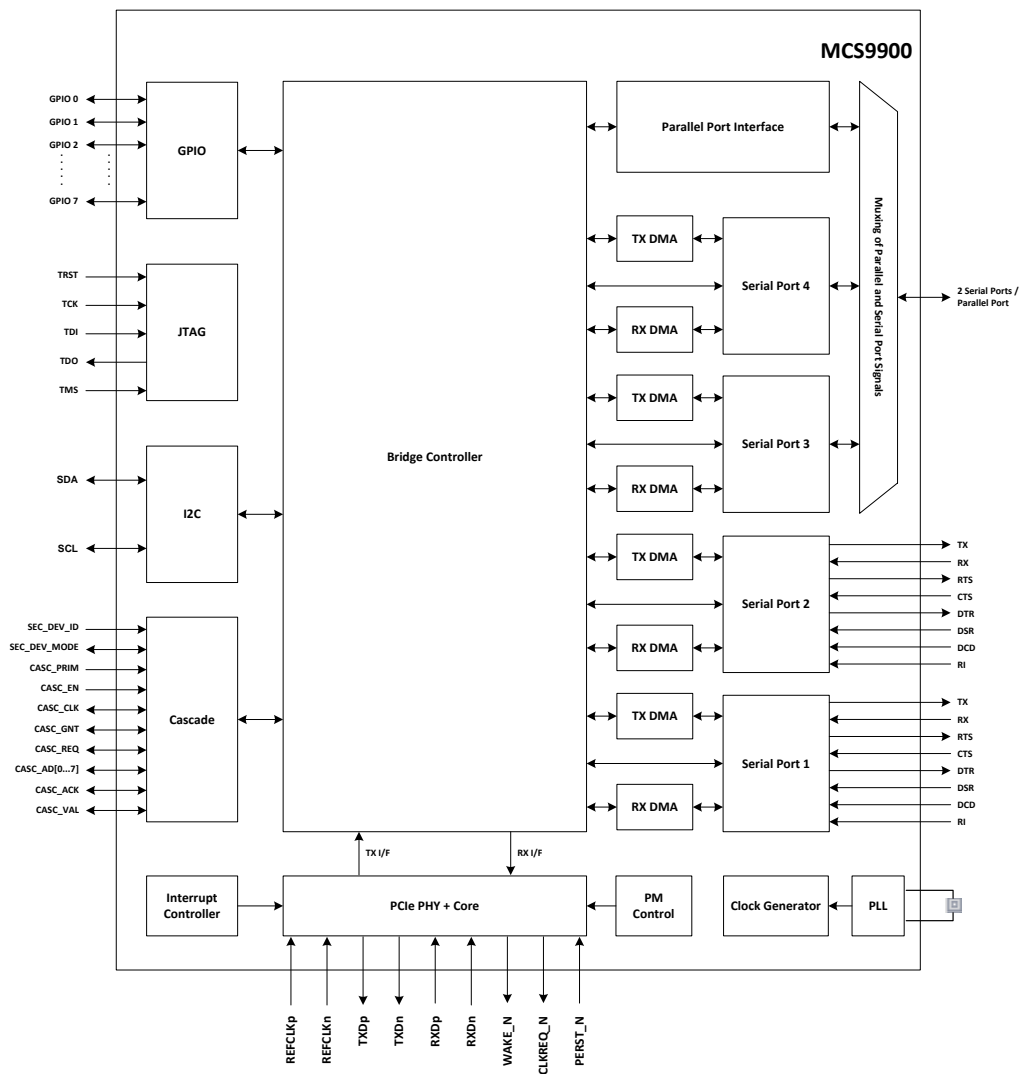

1.2 Features

PCI express

- Single-lane (X1) PCI Express End-point Controller with integrated PHY
- Compliant with PCI Express Base Specification, Revision 1.1
- Compliant with PCI Express card specifications
- Supports four PCI Express functions
- Supports auto completion of configuration requests
- Supports built in flow control
- Supports Message TLP (Error) generation
- Supports integrated time out handling of Non-posted request
- Supports both legacy and MSI Interrupt
- Supports PCIe Power Management

Serial Port

- Four 16C450 / 550 / Extended 550 / 650 / MosChip Enhanced Mode compatible UARTs
- Supports RS232, RS422 & RS485 modes
- Bi-directional speeds from 50 bps to 16 Mbps per port
- Full Serial Modem Control
- Supports Hardware, Software Flow Control
- Supports 5, 6, 7, 8 bit Serial format
- Supports Even, Odd, None, Space and Mark parity
- Supports Custom baud rate by programming internal PLL or external clock
- Supports On Chip 256 Byte depth FIFOs in Transmit, Receive path of each Serial Port
- Supports remote wakeup and power management features
- Serial Port transceiver shutdown support
- Supports Slow IrDA mode (up to 115200bps) on all Serial Ports

Parallel Port

- Compatible with IEEE 1284
- Nibble Mode
- Byte Mode
- Enhanced Parallel Port (EPP 1.9)
- Extended Capability Port (ECP)
- FIFO mode (Buffered SPP mode)

Cascade

MCS9900 supports a 13-Pin proprietary interface to connect to other cascade supported MosChip devices for IO expansion. For example, MCS9900 can interface with another MCS9900 to derive following product configurations.

- PCIe to 8 Serial Ports
- PCIe to 6 Serial Ports and 1 Parallel Port
- PCIe to 4 Serial Ports and 2 Parallel Ports

General Device Features

- I²C interface for EEPROM
- EEPROM read / write through PCIe Interface
- Up to 8 bi-directional multi-function GPIO lines
- On chip oscillator
- Power supply : 1.2V, 3.3V

1.3 Applications

- Serial Attached Devices
- Serial Networking / Monitoring Equipment
- Data Acquisition System
- POS Terminal & Industrial PC
- Parallel / Printer Port based applications
- Add-On I/O Cards – Serial / Parallel
- Embedded systems – For I/O expansion

1.4 Ordering information

- Ordering Part Number : MCS9900CV-AA
- Operating Temperature : 0 to 85 deg C
- Package : 128 LQFP, RoHS

1.5 Support

- Reference Schematics : Available ***
- Evaluation Board : Available ***
- Software Support : Available ***
- System Design Data & Other Technical Collateral : Available ***

*** Please contact MosChip Marketing or Application Support Team for the above items, write to marketing@moschip.com or techsupport@moschip.com

1.6 Package options

MCS9900 product family is offered in four different package options. The core product, MCS9900, offers full flexibility and supports all IO configurations. The other packages MCS9904CV-AA, MCS9922CV-AA and MCS9901CV-CC are optimized with fixed IO configurations as listed below.

Package	Description	Ordering Code
MCS9900CV-AA	Can be configured as 4-Serial or 2-Serial + 1-Parallel through Mode Select pins & also supports Cascade Master or Slave Mode.	MCS9900CV-AA
MCS9904CV_AA	Hardwired to 4-Serial mode. Can be programmed to lower configuration i.e 3-Serial or 2-Serial or 1-Serial through EEPROM. Supports Slave mode of Cascade.	MCS9904CV-AA
MCS9922CV-AA	Hardwired to 2-Serial mode. Can be programmed to lower configurations through EEPROM i.e 1 Serial. Supports Slave mode of Cascade.	MCS9922CV-AA
MCS9901CV-CC	Hardwired to 2-Serial + 1-Parallel mode. Can be programmed to lower configurations through EEPROM i.e 2-Serial or 1-Serial & 1-Parallel. Supports Slave mode of Cascade.	MCS9901CV-CC

Note : Mechanical dimensions of the package remains same for all 4 four part numbers listed in above Table. Refer to Section 8 for exact details of the package.

2 Pin Diagrams

2.1 MCS9900CV-AA Pin Diagram

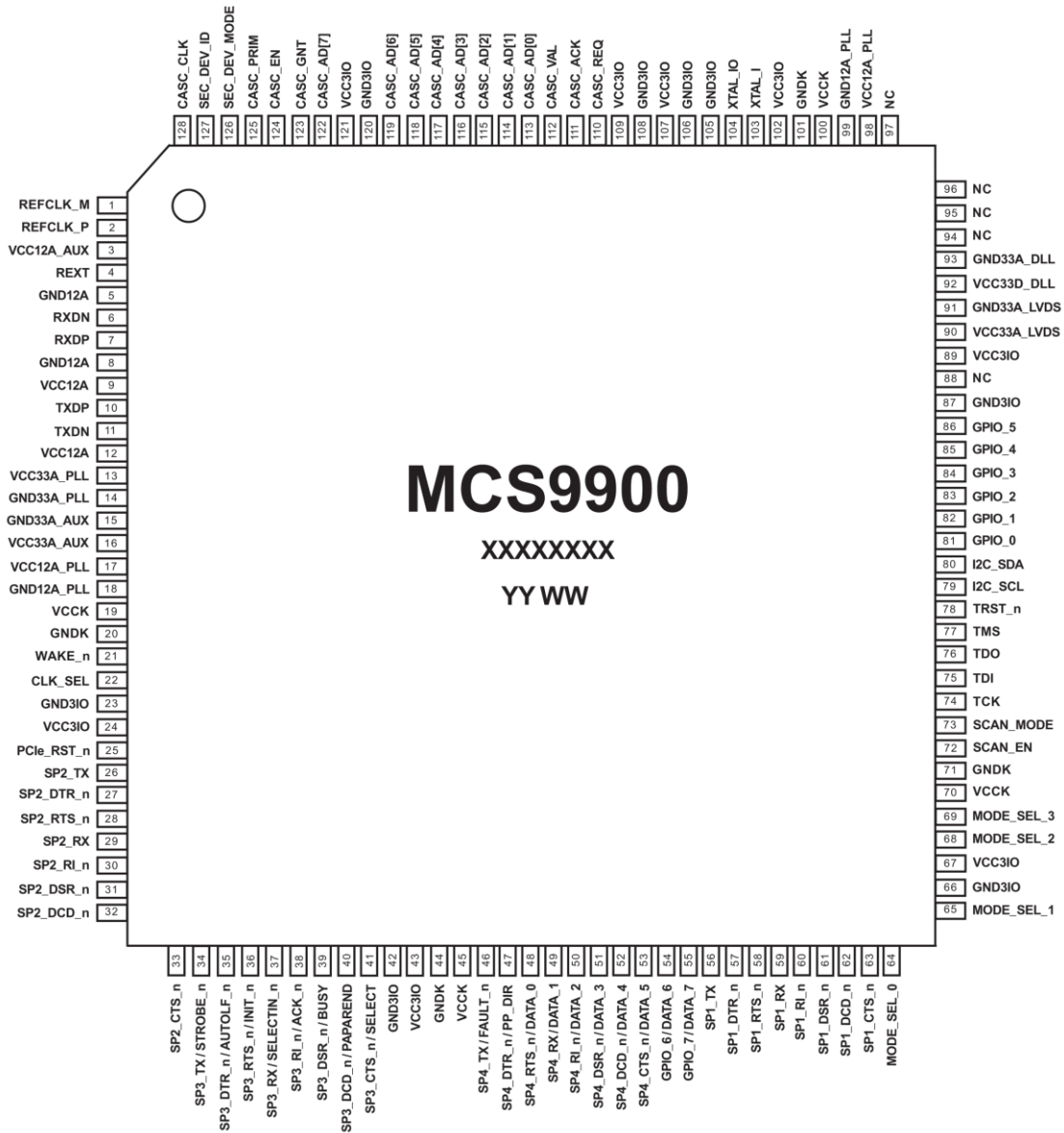

2.2 MCS9904CV-AA Pin diagram

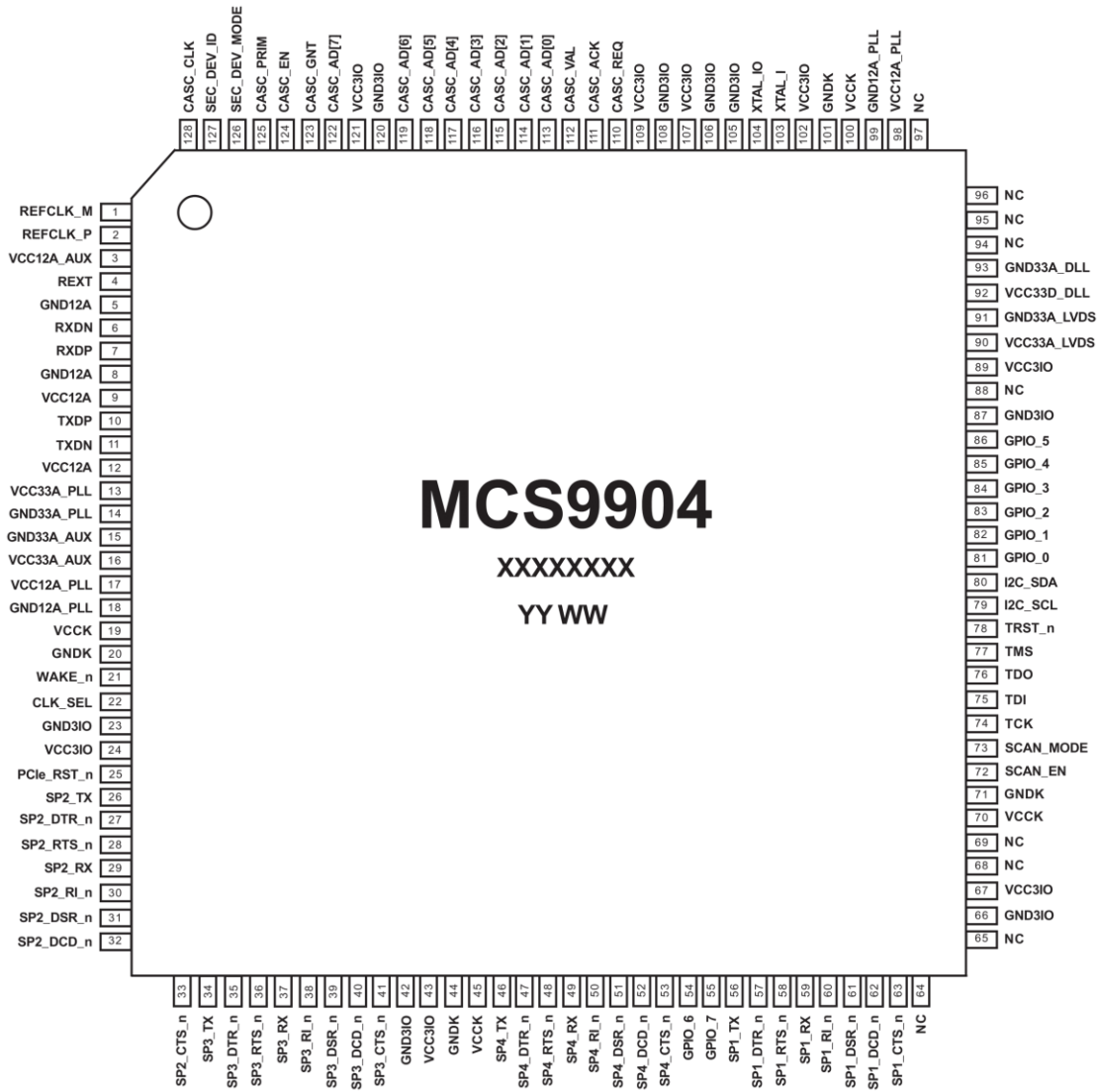

2.3 MCS9901CV-CC Pin diagram

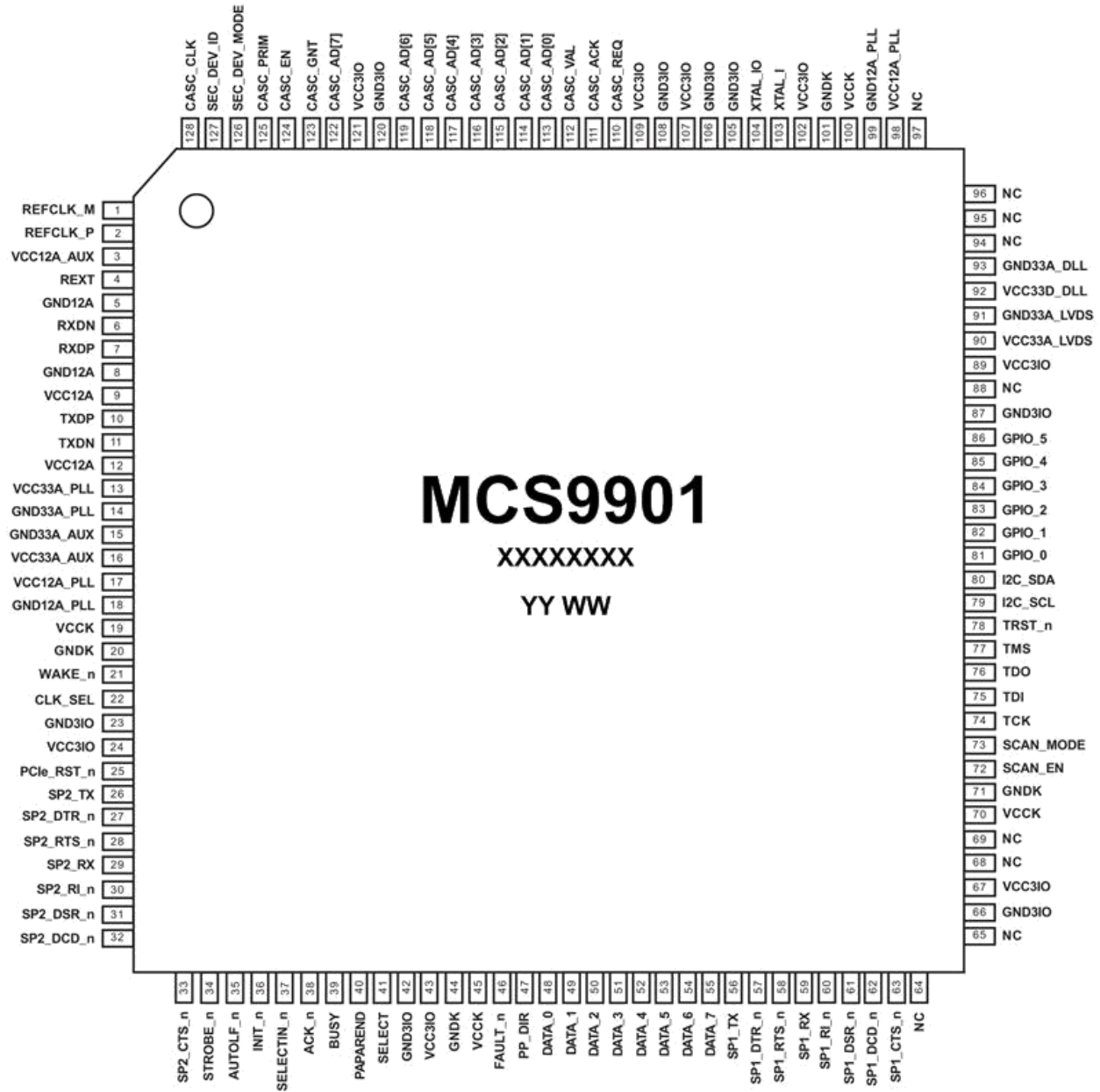

2.4 MCS9922CV-AA Pin diagram

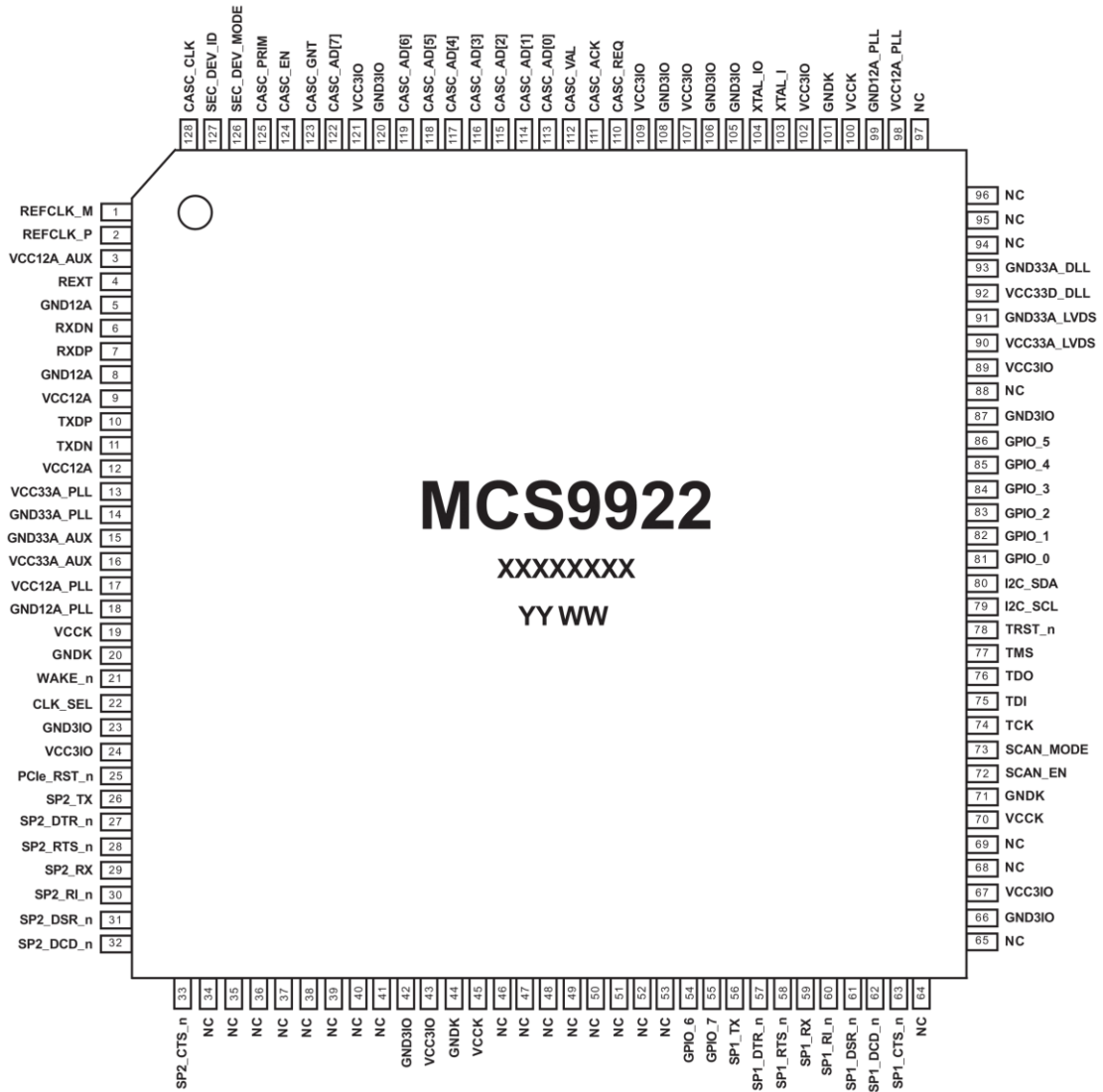

3 Pin Description

Pin Naming Convention

The Pin names use the following conventions:

“n” suffix is an active low signal, “I” – Input, “O” – Output, “P” – Passive, “DS” – Drive Strength in milli Amperes(mA), “PU” – Pull Up, “PD” – Pull Down, “N/A” – Not Applicable and “PROG” – Programmable

3.1 Pin configurations

Following table describes the pin configurations of MCS9900CV-AA, MCS9904CV-AA, MCS9901CV-CC, MCS9922CV-AA devices.

Pin	MCS9900CV-AA	MCS9904CV-AA	MCS9901CV-CC	MCS9922CV-AA
1	REFCLK_M	REFCLK_M	REFCLK_M	REFCLK_M
2	REFCLK_P	REFCLK_P	REFCLK_P	REFCLK_P
3	VCC12A_AUX	VCC12A_AUX	VCC12A_AUX	VCC12A_AUX
4	REXT	REXT	REXT	REXT
5	GND12A	GND12A	GND12A	GND12A
6	RXDN	RXDN	RXDN	RXDN
7	RXDP	RXDP	RXDP	RXDP
8	GND12A	GND12A	GND12A	GND12A
9	VCC12A	VCC12A	VCC12A	VCC12A
10	TXDP	TXDP	TXDP	TXDP
11	TXDN	TXDN	TXDN	TXDN
12	VCC12A	VCC12A	VCC12A	VCC12A
13	VCC33A_PLL	VCC33A_PLL	VCC33A_PLL	VCC33A_PLL
14	GND33A_PLL	GND33A_PLL	GND33A_PLL	GND33A_PLL
15	GND33A_AUX	GND33A_AUX	GND33A_AUX	GND33A_AUX
16	VCC33A_AUX	VCC33A_AUX	VCC33A_AUX	VCC33A_AUX
17	VCC12A_PLL	VCC12A_PLL	VCC12A_PLL	VCC12A_PLL
18	GND12A_PLL	GND12A_PLL	GND12A_PLL	GND12A_PLL
19	VCCK	VCCK	VCCK	VCCK
20	GNDK	GNDK	GNDK	GNDK
21	WAKE_n	WAKE_n	WAKE_n	WAKE_n
22	CLK_SEL	CLK_SEL	CLK_SEL	CLK_SEL
23	GND3IO	GND3IO	GND3IO	GND3IO
24	VCC3IO	VCC3IO	VCC3IO	VCC3IO
25	PCIe_RST_n	PCIe_RST_n	PCIe_RST_n	PCIe_RST_n
26	SP2_TX	SP2_TX	SP2_TX	SP2_TX
27	SP2_DTR_n	SP2_DTR_n	SP2_DTR_n	SP2_DTR_n
28	SP2_RTS_n	SP2_RTS_n	SP2_RTS_n	SP2_RTS_n
29	SP2_RX	SP2_RX	SP2_RX	SP2_RX
30	SP2_RI_n	SP2_RI_n	SP2_RI_n	SP2_RI_n
31	SP2_DSR_n	SP2_DSR_n	SP2_DSR_n	SP2_DSR_n
32	SP2_DCD_n	SP2_DCD_n	SP2_DCD_n	SP2_DCD_n
33	SP2_CTS_n	SP2_CTS_n	SP2_CTS_n	SP2_CTS_n
34*	SP3_TX / STROBE_n	SP3_TX	STROBE_n	NC
35*	SP3_DTR_n / AUTOLF_n	SP3_DTR_n	AUTOLF_n	NC

Pin	MCS9900CV-AA	MCS9904CV-AA	MCS9901CV-CC	MCS9922CV-AA
36*	SP3_RTS_n / INIT_n	SP3_RTS_n	INIT_n	NC
37*	SP3_RX / SELECTIN_n	SP3_RX	SELECTIN_n	NC
38*	SP3_RI_n / ACK_n	SP3_RI_n	ACK_n	NC
39*	SP3_DSR_n / BUSY	SP3_DSR_n	BUSY	NC
40*	SP3_DCD_n / PAPEREND	SP3_DCD_n	PAPEREND	NC
41*	SP3_CTS_n / SELECT	SP3_CTS_n	SELECT	NC
42	GND3IO	GND3IO	GND3IO	GND3IO
43	VCC3IO	VCC3IO	VCC3IO	VCC3IO
44	GNDK	GNDK	GNDK	GNDK
45	VCCK	VCCK	VCCK	VCCK
46*	SP4_TX / FAULT_n	SP4_TX	FAULT_n	NC
47*	SP4_DTR_n / PP_DIR	SP4_DTR_n	PP_DIR	NC
48*	SP4_RTS_n / DATA_0	SP4_RTS_n	DATA_0	NC
49*	SP4_RX / DATA_1	SP4_RX	DATA_1	NC
50*	SP4_RI_n / DATA_2	SP4_RI_n	DATA_2	NC
51*	SP4_DSR_n / DATA_3	SP4_DSR_n	DATA_3	NC
52*	SP4_DCD_n / DATA_4	SP4_DCD_n	DATA_4	NC
53*	SP4_CTS_n / DATA_5	SP4_CTS_n	DATA_5	NC
54 [†]	GPIO_6 / DATA_6	GPIO_6	DATA_6	GPIO_6
55 [†]	GPIO_7 / DATA_7	GPIO_7	DATA_7	GPIO_7
56	SP1_TX	SP1_TX	SP1_TX	SP1_TX
57	SP1_DTR_n	SP1_DTR_n	SP1_DTR_n	SP1_DTR_n
58	SP1_RTS_n	SP1_RTS_n	SP1_RTS_n	SP1_RTS_n
59	SP1_RX	SP1_RX	SP1_RX	SP1_RX
60	SP1_RI_n	SP1_RI_n	SP1_RI_n	SP1_RI_n
61	SP1_DSR_n	SP1_DSR_n	SP1_DSR_n	SP1_DSR_n
62	SP1_DCD_n	SP1_DCD_n	SP1_DCD_n	SP1_DCD_n
63	SP1_CTS_n	SP1_CTS_n	SP1_CTS_n	SP1_CTS_n
64	MODE_SEL_0	NC	NC	NC
65	MODE_SEL_1	NC	NC	NC
66	GND3IO	GND3IO	GND3IO	GND3IO
67	VCC3IO	VCC3IO	VCC3IO	VCC3IO
68	MODE_SEL_2	NC	NC	NC
69	MODE_SEL_3	NC	NC	NC
70	VCCK	VCCK	VCCK	VCCK
71	GNDK	GNDK	GNDK	GNDK
72	SCAN_EN	SCAN_EN	SCAN_EN	SCAN_EN
73	SCAN_MODE	SCAN_MODE	SCAN_MODE	SCAN_MODE
74	TCK	TCK	TCK	TCK
75	TDI	TDI	TDI	TDI
76	TDO	TDO	TDO	TDO
77	TMS	TMS	TMS	TMS
78	TRST_n	TRST_n	TRST_n	TRST_n
79	I2C_SCL	I2C_SCL	I2C_SCL	I2C_SCL
80	I2C_SDA	I2C_SDA	I2C_SDA	I2C_SDA
81	GPIO_0	GPIO_0	GPIO_0	GPIO_0
82	GPIO_1	GPIO_1	GPIO_1	GPIO_1
83	GPIO_2	GPIO_2	GPIO_2	GPIO_2

Pin	MCS9900CV-AA	MCS9904CV-AA	MCS9901CV-CC	MCS9922CV-AA
84	GPIO_3	GPIO_3	GPIO_3	GPIO_3
85	GPIO_4	GPIO_4	GPIO_4	GPIO_4
86	GPIO_5	GPIO_5	GPIO_5	GPIO_5
87	GND3IO	GND3IO	GND3IO	GND3IO
88	NC	NC	NC	NC
89	VCC3IO	VCC3IO	VCC3IO	VCC3IO
90	VCC33A_LVDS	VCC33A_LVDS	VCC33A_LVDS	VCC33A_LVDS
91	GND33A_LVDS	GND33A_LVDS	GND33A_LVDS	GND33A_LVDS
92	VCC33D_DLL	VCC33D_DLL	VCC33D_DLL	VCC33D_DLL
93	GND33A_DLL	GND33A_DLL	GND33A_DLL	GND33A_DLL
94	NC	NC	NC	NC
95	NC	NC	NC	NC
96	NC	NC	NC	NC
97	NC	NC	NC	NC
98	VCC12A_PLL	VCC12A_PLL	VCC12A_PLL	VCC12A_PLL
99	GND12A_PLL	GND12A_PLL	GND12A_PLL	GND12A_PLL
100	VCCK	VCCK	VCCK	VCCK
101	GNDK	GNDK	GNDK	GNDK
102	VCC3IO	VCC3IO	VCC3IO	VCC3IO
103	XTAL_I	XTAL_I	XTAL_I	XTAL_I
104	XTAL_IO	XTAL_IO	XTAL_IO	XTAL_IO
105	GND3IO	GND3IO	GND3IO	GND3IO
106	GND3IO	GND3IO	GND3IO	GND3IO
107	VCC3IO	VCC3IO	VCC3IO	VCC3IO
108	GND3IO	GND3IO	GND3IO	GND3IO
109	VCC3IO	VCC3IO	VCC3IO	VCC3IO
110	CASC_REQ	CASC_REQ	CASC_REQ	CASC_REQ
111	CASC_ACK	CASC_ACK	CASC_ACK	CASC_ACK
112	CASC_VAL	CASC_VAL	CASC_VAL	CASC_VAL
113	CASC_AD[0]	CASC_AD[0]	CASC_AD[0]	CASC_AD[0]
114	CASC_AD[1]	CASC_AD[1]	CASC_AD[1]	CASC_AD[1]
115	CASC_AD[2]	CASC_AD[2]	CASC_AD[2]	CASC_AD[2]
116	CASC_AD[3]	CASC_AD[3]	CASC_AD[3]	CASC_AD[3]
117	CASC_AD[4]	CASC_AD[4]	CASC_AD[4]	CASC_AD[4]
118	CASC_AD[5]	CASC_AD[5]	CASC_AD[5]	CASC_AD[5]
119	CASC_AD[6]	CASC_AD[6]	CASC_AD[6]	CASC_AD[6]
120	GND3IO	GND3IO	GND3IO	GND3IO
121	VCC3IO	VCC3IO	VCC3IO	VCC3IO
122	CASC_AD[7]	CASC_AD[7]	CASC_AD[7]	CASC_AD[7]
123	CASC_GNT	CASC_GNT	CASC_GNT	CASC_GNT
124	CASC_EN	CASC_EN	CASC_EN	CASC_EN
125	CASC_PRIM	CASC_PRIM	CASC_PRIM	CASC_PRIM
126	SEC_DEV_MODE	SEC_DEV_MODE	SEC_DEV_MODE	SEC_DEV_MODE
127	SEC_DEV_ID	SEC_DEV_ID	SEC_DEV_ID	SEC_DEV_ID
128	CASC_CLK	CASC_CLK	CASC_CLK	CASC_CLK

Note:

+ Indicates that these pins are multiplexed for GPIO and Parallel port configurations in MCS9900 device.

* Indicates that these pins are multiplexed for Serial ports (SP3 and SP4) and Parallel port configurations in MCS9900 device.

3.2 PCI Express Interface Signals

Pin#	Pin Name	I/O/P	Type	DS	PU/PD	Description
1	REFCLK_M	I	LVDS	–	–	PCIe PHY differential PLL reference clock.
2	REFCLK_P	I	LVDS	–	–	PCIe PHY differential PLL reference clock.
4	REXT	O	Analog	–	–	Bandgap External Resistor (Connect this pin to ground through an external resistor of 6.2K Ω , \pm 1%)
6	RXDN	I	LVDS	–	–	PCIe PHY differential negative serial data input.
7	RXDP	I	LVDS	–	–	PCIe PHY differential positive serial data input.
10	TXDP	O	LVDS	–	–	PCIe PHY differential positive serial data output.
11	TXDN	O	LVDS	–	–	PCIe PHY differential negative serial data output.
21	WAKE_n	O	LVTTTL	4	PU	This is an active low signal used to reactivate the PCI Express slot's main power and reference clocks.
22	CLK_SEL	O	LVTTTL	4	PU	Used to enable/disable clock of PCI Express card.
25	PCIe_RST_n	I	LVTTTL	4	PU	Active low asynchronous reset from PCIe RC

3.3 Serial Port Interface Signals

Serial Port 1

Pin#	Pin name	I/O/P	Type	DS	PU/PD	Description
56	SP1_TX	O	LVTTTL	4	–	Transmit data out to transceiver or IrDA data out to IR LED
57	SP1_DTR_n	O	LVTTTL	4	–	Data terminal ready (Active Low) Also used for setting cascade clock Pull up : Sets cascade clock to run at 62.5 MHz Pull down : Sets cascade clock to run at 96 MHz
58	SP1_RTS_n	O	LVTTTL	4	–	Request to send (Active Low)
59	SP1_RX	I	LVTTTL	4	PU	Serial receives data in from transceiver or IrDA data in from IrDA detector.
60	SP1_RI_n	I	LVTTTL	4	PU	Ring Indicator (Active Low)
61	SP1_DSR_n	I	LVTTTL	4	PU	Data Set Ready (Active Low)
62	SP1_DCD_n	I	LVTTTL	4	PU	Data Carrier Detect (Active Low)
63	SP1_CTS_n	I	LVTTTL	4	PU	Clear to send (Active Low)

Serial Port 2

Pin#	Pin name	I/O/P	Type	DS	PU/PD	Description
26	SP2_TX	O	LVTTTL	4	–	Transmit data out to transceiver or IrDA data out to IR LED
27	SP2_DTR_n	O	LVTTTL	4	–	Data terminal ready (Active Low)
28	SP2_RTS_n	O	LVTTTL	4	–	Request to send (Active Low)
29	SP2_RX	I	LVTTTL	4	PU	Serial receives data in from transceiver or IrDA data in from IrDA detector.
30	SP2_RI_n	I	LVTTTL	4	PU	Ring Indicator (Active Low)
31	SP2_DSR_n	I	LVTTTL	4	PU	Data Set Ready (Active Low)
32	SP2_DCD_n	I	LVTTTL	4	PU	Data Carrier Detect (Active Low)
33	SP2_CTS_n	I	LVTTTL	4	PU	Clear to send (Active Low)

Serial Port 3

Pin#	Pin name	I/O/P	Type	DS	PU/PD	Description
34	SP3_TX	O	LVTTTL	12	–	Transmit data out to transceiver or IrDA data out to IR LED
35	SP3_DTR_n	O	LVTTTL	12	–	Data terminal ready (Active Low)
36	SP3_RTS_n	O	LVTTTL	12	–	Request to send (Active Low)
37	SP3_RX	I	LVTTTL	12	PU	Serial receives data in from transceiver or IrDA data in from IrDA detector.
38	SP3_RI_n	I	LVTTTL	4	PU	Ring Indicator (Active Low)
39	SP3_DSR_n	I	LVTTTL	4	PU	Data Set Ready (Active Low)
40	SP3_DCD_n	I	LVTTTL	4	PU	Data Carrier Detect (Active Low)
41	SP3_CTS_n	I	LVTTTL	4	PU	Clear to send (Active Low)

Serial Port 4

Pin#	Pin name	I/O/P	Type	DS	PU/PD	Description
46	SP4_TX	O	LVTTTL	4	–	Transmit data out to transceiver or IrDA data out to IR LED
47	SP4_DTR_n	O	LVTTTL	4	–	Data terminal ready (Active Low)
48	SP4_RTS_n	O	LVTTTL	12	–	Request to send (Active Low)
49	SP4_RX	I	LVTTTL	12	PU	Serial receives data in from transceiver or IrDA data in from IrDA detector.
50	SP4_RI_n	I	LVTTTL	12	PU	Ring Indicator (Active Low)
51	SP4_DSR_n	I	LVTTTL	12	PU	Data Set Ready (Active Low)
52	SP4_DCD_n	I	LVTTTL	12	PU	Data Carrier Detect (Active Low)
53	SP4_CTS_n	I	LVTTTL	12	PU	Clear to send (Active Low)

3.4 Parallel port Interface signals

Pin#	Pin name	I/O/P	Type	DS	PU/PD	Description
34	STROBE_n	O	LVTTTL	12	–	Set active low by the host to transfer data into the input latch of the peripheral. Data are valid while STROBE_N is low.
35	AUTOLF_n	O	LVTTTL	12	–	The interpretation of this signal varies from peripheral to peripheral. Set low by host to put some printers into auto-line feed mode
36	INIT_n	O	LVTTTL	12	–	Pulsed low by the host in conjunction with IEEE 1284 Active low to reset the interface and force a return to Compatibility Mode idle phase
37	SELECTIN_n	I/O	LVTTTL	12	PU	Set low by host to select peripheral
38	ACK_n	I	LVTTTL	4	PU	Pulsed low by the peripheral to acknowledge transfer of a data byte from the host
39	BUSY	I	LVTTTL	4	PU	Driven high by the peripheral to indicate that it is not ready to receive data
40	PAPEREND	I	LVTTTL	4	PU	Driven high by the peripheral to indicate that it has encountered an error in its paper path. The meaning of this signal varies from peripheral to peripheral. Peripherals shall set FAULT_N low whenever PAPEREND is set high
41	SELECT	I	LVTTTL	4	PU	Set high to indicate that the peripheral is online
46	FAULT_n	I	LVTTTL	4	–	Set low by the peripheral to indicate that an error has occurred. The meaning of this signal varies from peripheral to peripheral

Pin#	Pin name	I/O/P	Type	DS	PU/PD	Description
47	PP_DIR	O	LVTTTL	4	–	Set low to indicate a data transfer direction of peripheral to host and set high to indicate a data transfer direction of host to peripheral
48	DATA_0	I/O	LVTTTL	12	–	Driven by the host in Compatibility Mode and the negotiation phase, not used in Nibble Mode, and bidirectional in all other modes
49	DATA_1	I/O	LVTTTL	12	PU	Driven by the host in Compatibility Mode and the negotiation phase, not used in Nibble Mode, and bidirectional in all other modes
50	DATA_2	I/O	LVTTTL	12	PU	Driven by the host in Compatibility Mode and the negotiation phase, not used in Nibble Mode, and bidirectional in all other modes
51	DATA_3	I/O	LVTTTL	12	PU	Driven by the host in Compatibility Mode and the negotiation phase, not used in Nibble Mode, and bidirectional in all other modes
52	DATA_4	I/O	LVTTTL	12	PU	Driven by the host in Compatibility Mode and the negotiation phase, not used in Nibble Mode, and bidirectional in all other modes
53	DATA_5	I/O	LVTTTL	12	PU	Driven by the host in Compatibility Mode and the negotiation phase, not used in Nibble Mode, and bidirectional in all other modes

Pin#	Pin name	I/O/P	Type	DS	PU/PD	Description
54	DATA_6	I/O	LVTTTL	8	PU/PD	Driven by the host in Compatibility Mode and the negotiation phase, not used in Nibble Mode, and bidirectional in all other modes
55	DATA_7	I/O	LVTTTL	8	PU/PD	Driven by the host in Compatibility Mode and the negotiation phase, not used in Nibble Mode, and bidirectional in all other modes

3.5 Cascade Interface Signals

Pin#	Pin name	I/O/P	Type	DS	PU/PD	Description
110	CASC_REQ	I/O	LVTTTL	8	–	To request the arbiter to grant access to CASC_AD bus.
111	CASC_ACK	I/O	LVTTTL	8	–	Asserted by slave, in response to CASC_VAL, when it is ready to accept transfer
112	CASC_VAL	I/O	LVTTTL	8	–	1: address/data/command on CASC_AD[7:0] is valid, 0: CASC_AD is not valid
113	CASC_AD[0]	I/O	LVTTTL	8	–	To transfer Address / Data and control words
114	CASC_AD[1]	I/O	LVTTTL	8	–	To transfer Address / Data and control words
115	CASC_AD[2]	I/O	LVTTTL	8	–	To transfer Address / Data and control words
116	CASC_AD[3]	I/O	LVTTTL	8	–	To transfer Address / Data and control words
117	CASC_AD[4]	I/O	LVTTTL	8	–	To transfer Address / Data and control words
118	CASC_AD[5]	I/O	LVTTTL	8	–	To transfer Address / Data and control words
119	CASC_AD[6]	I/O	LVTTTL	8	–	To transfer Address / Data and control words
122	CASC_AD[7]	I/O	LVTTTL	8	–	To transfer Address / Data and control words

Pin#	Pin name	I/O/P	Type	DS	PU/PD	Description
123	CASC_GNT	I/O	LVTTTL	8	–	Grant to access of CASC_AD bus
124	CASC_EN	I	LVTTTL	4	PD	Leave this pin as “No Connect” for Non-Cascade applications. 1 : cascade mode enabled 0 : cascade mode disabled
125	CASC_PRIM	I	LVTTTL	4	PD	1 : Chip is cascade primary 0 : Chip is cascade secondary
126	SEC_DEV_MODE	I/O	LVTTTL	8	PD	For Non-Cascade applications, leave this pin as No Connect. <u>For Cascade applications :</u> 1 : Secondary chip is in 2S1P mode 0 : Secondary chip is in 4S mode This pin is output for Cascade secondary device and input to Cascade primary device.
127	SEC_DEV_ID	I	LVTTTL	4	PD	Leave this pin as “No Connection” for Non-Cascade applications. For Cascade applications 0 : Secondary chip is MCS9900 / 9904 / MCS9901CV-CC 1 : Reserved for 3 rd Party Devices
128	CASC_CLK	O	LVTTTL	8		Cascade clock output of primary chip. Refer to Cascade application schematic for interface details. When MCS9900 is used as Cascade Secondary, Pull down using 1K resistor.

3.6 I²C Interface Signals

Pin#	Pin name	I/O/P	Type	DS	PU/PD	Description
79	I2C_SCL	I/O	LVTTTL	4	PU	2-Wire EEPROM Clock
80	I2C_SDA	I/O	LVTTTL	4	PU	2-Wire EEPROM Data in/out.

3.7 GPIO Interface Signals

Pin#	Pin name	I/O/P	Type	DS	PU/PD	Description
81	GPIO_0	I/O	LVTTTL	8	PU/PD	General Purpose I/O signal
82	GPIO_1	I/O	LVTTTL	8	PU/PD	General Purpose I/O signal
83	GPIO_2	I/O	LVTTTL	8	PU/PD	General Purpose I/O signal
84	GPIO_3	I/O	LVTTTL	8	PU/PD	General Purpose I/O signal
85	GPIO_4	I/O	LVTTTL	8	PU/PD	General Purpose I/O signal
86	GPIO_5	I/O	LVTTTL	8	PU/PD	General Purpose I/O signal
54*	GPIO_6	I/O	LVTTTL	8	PU/PD	General Purpose I/O signal
55*	GPIO_7	I/O	LVTTTL	8	PU/PD	General Purpose I/O signal

* These pins are not available when the chip is configured for parallel port.

3.8 Clock/Crystal Oscillator Interface Signals

Pin#	Pin name	I/O/P	Type	DS	PU/PD	Description
103	XTAL_I	I	Analog	–	–	Crystal input for PLL, 1 ~ 40MHz
104	XTAL_IO	I/O	Analog	–	–	Feedback signal for the oscillator pad

3.9 Mode Select Signals

Pin#	Pin name	I/O/P	Type	DS	PU/PD	Description
64	MODE_SEL_0	I	LVTTTL	4	PD	Mode select
65	MODE_SEL_1	I	LVTTTL	4	PD	Mode select
68	MODE_SEL_2	I	LVTTTL	4	PD	Mode select
69	MODE_SEL_3	I	LVTTTL	4	PD	Mode select

3.10 Test Mode Signals

Pin#	Pin name	I/O/P	Type	DS	PU/PD	Description
72	SCAN_EN	I	LVTTTL	4	PD	Scan enable signal
73	SCAN_MODE	I	LVTTTL	4	–	This signal is used as clock input in cascade mode. In cascade mode, clock is driven by 'primary' through 'CASC_CLK' and brought back through this pin to both primary and secondary through an external onboard connection.

3.11 JTAG Interface Signals

Pin#	Pin name	I/O/P	Type	DS	PU/PD	Description
74	TCK	I	LVTTL	4	–	JTAG chain clock
75	TDI	I	LVTTL	4	PD	JTAG chain input
76	TDO	O	LVTTL	4	–	JTAG chain output
77	TMS	I	LVTTL	4	PD	JTAG chain Test mode select
78	TRST_n	I	LVTTL	4	PU	JTAG Reset (pull-up is recommended on JTAG Reset)

3.12 Power Supply Signals

Pin#	Pin name	I/O/P	Type	DS	PU/PD	Description
3	VCC12A_AUX	P	PWR	–	–	1.2V Analog Power Supply
9	VCC12A	P	PWR	–	–	1.2V Analog Power Supply
12	VCC12A	P	PWR	–	–	1.2V Analog Power Supply
13	VCC33A_PLL	P	PWR	–	–	3.3V Analog Power Supply
16	VCC33A_AUX	P	PWR	–	–	3.3V Analog Power Supply
17	VCC12A_PLL	P	PWR	–	–	1.2V Analog Power Supply
19	VCCK	P	PWR	–	–	1.2V Digital Power Supply
24	VCC3IO	P	PWR	–	–	3.3V Digital Power Supply
43	VCC3IO	P	PWR	–	–	3.3V Digital Power Supply
45	VCCK	P	PWR	–	–	1.2V Digital Power Supply
67	VCC3IO	P	PWR	–	–	3.3V Digital Power Supply
70	VCCK	P	PWR	–	–	1.2V Digital Power Supply
89	VCC3IO	P	PWR	–	–	3.3V Digital Power Supply
90	VCC33A_LVDS	P	PWR	–	–	3.3V Analog Power Supply
92	VCC33D_DLL	P	PWR	–	–	3.3V Digital Power Supply
98	VCC12A_PLL	P	PWR	–	–	1.2V Analog Power Supply
100	VCCK	P	PWR	–	–	1.2V Digital Power Supply
102	VCC3IO	P	PWR	–	–	3.3V Digital Power Supply
107	VCC3IO	P	PWR	–	–	3.3V Digital Power Supply
109	VCC3IO	P	PWR	–	–	3.3V Digital Power Supply

Pin#	Pin name	I/O/P	Type	DS	PU/PD	Description
121	VCC3IO	P	PWR	–	–	3.3V Digital Power Supply
5	GND12A	P	PWR	–	–	Analog Ground
8	GND12A	P	PWR	–	–	Analog Ground
14	GND33A_PLL	P	PWR	–	–	Analog Ground
15	GND33A_AUX	P	PWR	–	–	Analog Ground
18	GND12A_PLL	P	PWR	–	–	Analog Ground
20	GNDK	P	PWR	–	–	Digital Ground
23	GND3IO	P	PWR	–	–	Digital Ground
42	GND3IO	P	PWR	–	–	Digital Ground
44	GNDK	P	PWR	–	–	Digital Ground
66	GND3IO	P	PWR	–	–	Digital Ground
71	GNDK	P	PWR	–	–	Digital Ground
87	GND3IO	P	PWR	–	–	Digital Ground
91	GND33A_LVDS	P	PWR	–	–	Analog Ground
93	GND33A_DLL	P	PWR	–	–	Analog Ground
99	GND12A_PLL	P	PWR	–	–	Analog Ground
101	GNDK	P	PWR	–	–	Digital Ground
105	GND3IO	P	PWR	–	–	Digital Ground
106	GND3IO	P	PWR	–	–	Digital Ground
108	GND3IO	P	PWR	–	–	Digital Ground
120	GND3IO	P	PWR	–	–	Digital Ground

Note : Pin Numbers 88, 94, 95, 96 & 97 are No Connect Pins for MCS9900. For derivative packages, refer to Section 3.1 for No Connect Pin details.

4 Mode Selection and Function Mapping

Non-Cascade Mode Selection

Chip Mode	Mode Selection Register Values	
4 Serial	MODE_SEL[3:0] = 4'b0 = 0000 ₂	SEC_DEV_ID = 1'b0
	CASC_EN = 1'b0	
2 Serial + 1 Parallel	MODE_SEL[3:0] = 4'b1 = 0001 ₂	SEC_DEV_ID = 1'b0
	CASC_EN = 1'b0	

Cascade Mode Selection

Chip Mode	Register Values			
	Primary Mode Selection		Secondary Mode Selection	
8 Serial	MODE_SEL[3:0] = 4'b0000	SEC_DEV_ID = 1'b0	CASC_EN = 1'b1	CASC_PRIM = 1'b1
	CASC_PRIM = 1'b1	MODE_SEL[3:0] = 4'b0000	SEC_DEV_ID = 1'b0	CASC_EN = 1'b1
	CASC_PRIM = 1'b1	CASC_PRIM = 1'b0	MODE_SEL[3:0] = 4'b0001	SEC_DEV_ID = 1'b0
6 Serial + 1 Parallel	MODE_SEL[3:0] = 4'b0000	SEC_DEV_ID = 1'b0	CASC_EN = 1'b1	CASC_PRIM = 1'b0
	CASC_PRIM = 1'b1	MODE_SEL[3:0] = 4'b0001	SEC_DEV_ID = 1'b0	CASC_EN = 1'b1
	CASC_PRIM = 1'b1	CASC_PRIM = 1'b0	MODE_SEL[3:0] = 4'b0001	SEC_DEV_ID = 1'b0
4 Serial + 2 Parallel	MODE_SEL[3:0] = 4'b0001	SEC_DEV_ID = 1'b0	CASC_EN = 1'b1	CASC_PRIM = 1'b1
	CASC_PRIM = 1'b1	MODE_SEL[3:0] = 4'b0001	SEC_DEV_ID = 1'b0	CASC_EN = 1'b1
	CASC_PRIM = 1'b1	CASC_PRIM = 1'b0	MODE_SEL[3:0] = 4'b0001	SEC_DEV_ID = 1'b0

Function Mapping

Function	Non – Cascade Mode		Cascade Mode		
	4 Serial	2 Serial + 1 Parallel	8 Serial	6 Serial + 1 Parallel	4 Serial + 2 Parallel
Function 0	Serial Port 1	Serial Port 1	Serial Port 1 Serial Port 5	Serial Port 1 Serial Port 5	Serial Port 1 Serial Port 3
Function 1	Serial Port 2	Serial Port 2	Serial Port 2 Serial Port 6	Serial Port 2 Serial Port 6	Serial Port 2 Serial Port 4
Function 2	Serial Port 3	Parallel Port	Serial Port 3 Serial Port 7	Serial Port 3 Parallel Port	Parallel Port 1 Parallel Port 2
Function 3	Serial Port 4		Serial Port 4 Serial port 8	Serial Port 4	–

5 Functional Description

MCS9900 family (MCS9900CV-AA, MCS9904CV-AA, MCS9901CV-CC and MCS9922CV-AA) is a single lane PCI Express based multifunction peripheral controller which supports 4-Port UART Controller, Parallel Port Controller, Cascade Controller, GPIO Controller, an I²C Controller and a bridge to control the transfers between the interfaces and PCIe.

The Serial port controllers are compatible with 16C450/550/Extended 550. It supports RS232, RS422 and RS485 standards with bi-directional speeds from 50bps to 16Mbps/port. And also supports Custom BAUD rates with external clock or by programming internal PLL. Each Serial port controller uses an on-chip 256 byte deep FIFO in Transmit and receive paths.

The Parallel Port controller is a multi-mode IEEE 1284 complaint, which supports Nibble, Byte, SPP, ECP and EPP modes.

The Cascade interface is a 13-pin MosChip proprietary interface which supports to add another cascade supported chip to expand the peripheral functions.

An I²C master interface is included to be able to connect to EPROM that could store PCIe device configuration. The 8-GPIO pins are programmable as an Input or Output.

5.1 PCIe Operation

PCIe is divided into three major blocks as Physical layer, Data link layer and Transaction layer. Physical link layer and Transaction layer together comprises PCIe core. Their functionality is explained below.

PCIe PHY

The Physical Layer isolates the Transaction and Data Link Layers from the signaling technology used for Link data interchange. The Physical Layer is divided into the logical and electrical functional sub-blocks.

The logical sub-block has two main sections: A transmit section that prepares outgoing information passed from the Data Link Layer for transmission by the electrical sub-block, and a receiver section that identifies and prepares received information before passing it to the Data Link Layer. The logical sub-block and electrical sub-block coordinate the state of each transceiver through a status and control register interface or functional equivalent. The logical sub-block directs control and management functions of the Physical Layer.

The electrical sub-block contains a Transmitter and a Receiver. The Transmitter is supplied by the logical sub-block with Symbols which it serializes and transmits onto a Lane. The Receiver is supplied with serialized Symbols from the Lane. It transforms the electrical signals into a bit stream which is de-serialized and supplied to the logical sub-block along with a Link clock recovered from the incoming serial stream.

The Physical Layer is responsible for the following:

- Power management
- Width and lane negotiation
- Reset/hot-plug control
- 8-bit/10-bit encoding/decoding
- Scrambling/de-scrambling
- Embedded clock tuning and alignment
- Transmission and reception circuit
- Elastic buffer
- Data Link Layer

The Data Link Layer:

The Data Link Layer acts as an intermediate stage between the Transaction Layer and the Physical Layer. The Data Link Layer is responsible for reliably conveying Transaction Layer Packets (TLPs) supplied by the Transaction Layer across a PCI Express Link to the other component's Transaction Layer

The Data Link Layer is responsible for the following:

- Link management including TLP acknowledgment
- Retry mechanism in case of a non-acknowledged packet
- Flow control across the Link (transmission and reception)
- Power management
- CRC generation and CRC checking
- Error reporting

Transaction Layer/User Interface Layer

Transaction layer and User interface layer together perform all transaction layer functionalities. User interface layer defines a plug-and-play type interface mechanism to accept TLPs from user space for transmission, and to pass received TLPs on reception.

The Transaction Layer is primarily responsible for the following:

- Assembly and disassembly of Transaction Layer packets (TLPs)
- Storage of configuration information
- Converts received Completion packets into data payloads,
- Updates status information
- Responsible for flow control services
- Ordering rules
- Power management services
- PCIe Bridge
- Master Slave Bridge is divided into PCIe packet formatter, PCIe target interface block, Mater arbiter, Slave de-mux and VCI interface block.

5.2 PCIe Configuration Space

The following table describes PCIe configuration space register value details for Non-Cascade and Cascade modes supported by MCS9900

Non cascade mode

Function	Register	MCS9900CV-AA (4S)	MCS9900CV-AA (2S1P)	MCS9904CV-AA	MCS9901CV-CC	MCS9922CV-AA
Function0	Device ID	16'h9900	16'h9900	16'h9904	16'h9912	16'h9922
	Vendor ID	16'h9710	16'h9710	16'h9710	16'h9710	16'h9710
	Revision ID	'h0	'h0	'h0	'h0	'h0
	Class code	'h7	'h7	'h7	'h7	'h7
	Sub Class Code	'h0	'h0	'h0	'h0	'h0
	Program interface	'h2	'h2	'h2	'h2	'h2
	Sub Vendor ID	'hA000	'hA000	'hA000	'hA000	'hA000
	Sub Device ID	'h1000	'h1000	'h1000	'h1000	'h1000
	Power Management Cap	16'h060F	16'h060F	16'h060F	16'h060F	16'h060F
	extended Capabilities	'h1	'h1	'h1	'h1	'h1
	Device Capabilities	16'h8302	16'h8302	16'h8302	16'h8302	16'h8302
	Link Capabilities	'h7	'h7	'h7	'h7	'h7
	MSI & Clock Power Mgmt Enable	8'h19	8'h19	8'h19	8'h19	8'h19
	Interrupt Pin	'h1	'h1	'h1	'h1	'h1
Function1	Device ID	16'h9900	16'h9900	16'h9904	16'h9912	16'h9922
	Vendor ID	16'h9710	16'h9710	16'h9710	16'h9710	16'h9710
	Revision ID	'h0	'h0	'h0	'h0	'h0
	Class code	'h7	'h7	'h7	'h7	'h7
	Sub Class Code	'h0	'h0	'h0	'h0	'h0
	Program interface	'h2	'h2	'h2	'h2	'h2
	Sub Vendor ID	'hA000	'hA000	'hA000	'hA000	'hA000
	Sub Device ID	'h1000	'h1000	'h1000	'h1000	'h1000
Power Management Cap	16'h060F	16'h060F	16'h060F	16'h060F	16'h060F	

Function	Register	MCS9900CV-AA (4S)	MCS9900CV-AA (2S1P)	MCS9904CV-AA	MCS9901CV-CC	MCS9922CV-AA
	extended Capabilities	'h1	'h1	'h1	'h1	'h1
	Device Capabilities	16'h8302	16'h8302	16'h8302	16'h8302	16'h8302
	Link Capabilities	'h7	'h7	'h7	'h7	'h7
	MSI & Clock Power Mgmt Enable	8'h19	8'h19	8'h19	8'h19	8'h19
	Interrupt Pin	'h2	'h2	'h2	'h2	'h2
Function2	Device ID	16'h9900	16'h9900	16'h9904	16'h9912	16'hFFFF
	Vendor ID	'h9710	'h9710	'h9710	'h9710	'hFFFF
	Revision ID	'h0	'h0	'h0	'h0	'h0
	Class code	'h7	'h7	'h7	'h7	'h0
	Sub Class Code	'h0	'h1	'h0	'h1	'h0
	Program interface	'h2	'h3	'h2	'h3	'h0
	Sub Vendor ID	'hA000	'hA000	'hA000	'hA000	'h0
	Sub Device ID	'h1000	'h2000	'h1000	'h2000	'h0
	Power Management Cap	16'h060F	16'h060F	16'h060F	16'h060F	'h0
	extended Capabilities	'h1	'h1	'h1	'h1	'h0
	Device Capabilities	16'h8302	16'h8302	16'h8302	16'h8302	'h0
	Link Capabilities	'h7	'h7	'h7	'h7	'h0
	MSI & Clock Power Mgmt Enable	'h19	'h1	'h19	'h1	'h0
	Interrupt Pin	'h3	'h3	'h3	'h3	'h0
Function3	Device ID	16'h9900	'hFFFF	'h9904	'hFFFF	'hFFFF
	Vendor ID	'h9710	'hFFFF	'h9710	'hFFFF	'hFFFF
	Revision ID	'h0	'h0	'h0	'h0	'h0
	Class code	'h7	'h0	'h7	'h0	'h0
	Sub Class Code	'h0	'h0	'h0	'h0	'h0
	Program interface	'h2	'h0	'h2	'h0	'h0
	Sub Vendor ID	'hA000	'h0	'hA000	'h0	'h0
	Sub Device ID	'h1000	'h0	'h1000	'h0	'h0

Function	Register	MCS9900CV-AA (4S)	MCS9900CV-AA (2S1P)	MCS9904CV-AA	MCS9901CV-CC	MCS9922CV-AA
	Power Management Cap	16'h060F	'h0	16'h060F	'h0	'h0
	extended Capabilities	'h1	'h0	'h1	'h0	'h0
	Device Capabilities	16'h8302	'h0	16'h8302	'h0	'h0
	Link Capabilities	'h7	'h0	'h7	'h0	'h0
	MSI & Clock Power Mgmt Enable	'h19	'h0	'h19	'h0	'h0
	Interrupt Pin	'h4	'h0	'h4	'h0	'h0

Cascade mode

Function	Register	4S+4S	4S+2S1P	2S1P+4S	2S1P+2S1P
Function0	Device ID	16'h9900	16'h9900	16'h9900	16'h9900
	Vendor ID	'h9710	'h9710	'h9710	'h9710
	Revision ID	'h0	'h0	'h0	'h0
	Class code	'h7	'h7	'h7	'h7
	Sub Class Code	'h80	'h80	'h80	'h80
	Program interface	'h0	'h0	'h0	'h0
	Sub Vendor ID	'hA000	'hA000	'hA000	'hA000
	Sub Device ID	'h3002	'h3002	'h3002	'h3002
	Power Management Cap	16'h060F	16'h060F	16'h060F	16'h060F
	extended Capabilities	'h1	'h1	'h1	'h1
	Device Capabilities	16'h8302	16'h8302	16'h8302	16'h8302
	Link Capabilities	'h7	'h7	'h7	'h7
	MSI & Clock Power Mgmt Enable	8'h29	8'h29	8'h29	8'h29
	Interrupt Pin	'h1	'h1	'h1	'h1
Function1	Device ID	16'h9900	16'h9900	16'h9900	16'h9900
	Vendor ID	'h9710	'h9710	'h9710	'h9710
	Revision ID	'h0	'h0	'h0	'h0
	Class code	'h7	'h7	'h7	'h7
	Sub Class Code	'h80	'h80	'h80	'h80
	Program interface	'h0	'h0	'h0	'h0
	Sub Vendor ID	'hA000	'hA000	'hA000	'hA000
	Sub Device ID	'h3002	'h3002	'h3002	'h3002
	Power Management Cap	16'h060F	16'h060F	16'h060F	16'h060F

Function	Register	4S+4S	4S+2S1P	2S1P+4S	2S1P+2S1P
	extended Capabilities	'h1	'h1	'h1	'h1
	Device Capabilities	16'h8302	16'h8302	16'h8302	16'h8302
	Link Capabilities	'h7	'h7	'h7	'h7
	MSI & Clock Power Mgmt Enable	8'h29	8'h29	8'h29	8'h29
	Interrupt Pin	'h2	'h2	'h2	'h2
Function2	Device ID	16'h9900	16'h9900	16'h9900	16'h9900
	Vendor ID	'h9710	'h9710	'h9710	'h9710
	Revision ID	'h0	'h0	'h0	'h0
	Class code	'h7	'h7	'h7	'h7
	Sub Class Code	'h80	'h80	'h80	'h80
	Program interface	'h0	'h0	'h0	'h0
	Sub Vendor ID	'hA000	'hA000	'hA000	'hA000
	Sub Device ID	'h3002	'h3011	'h3012	'h3020
	Power Management Cap	16'h060F	16'h060F	16'h060F	16'h060F
	extended Capabilities	'h1	'h1	'h1	'h1
	Device Capabilities	16'h8302	16'h8302	16'h8302	16'h8302
	Link Capabilities	'h7	'h7	'h7	'h7
	MSI & Clock Power Mgmt Enable	8'h29	8'h29	8'h29	8'h29
	Interrupt Pin	'h3	'h3	'h3	'h3
Function3	Device ID	16'h9900	16'h9900	16'h9900	'hFFFF
	Vendor ID	'h9710	'h9710	'h9710	'hFFFF
	Revision ID	'h0	'h0	'h0	'h0
	Class code	'h7	'h7	'h7	'h0
	Sub Class Code	'h80	'h80	'h80	'h0
	Program interface	'h0	'h0	'h0	'h0
	Sub Vendor ID	'hA000	'hA000	'hA000	'h0
	Sub Device ID	'h3002	'h1000	'h1000	'h0
	Power Management Cap	16'h060F	16'h060F	16'h060F	'h0
	extended Capabilities	'h1	'h1	'h1	'h0
	Device Capabilities	16'h8302	16'h8302	16'h8302	'h0
	Link Capabilities	'h7	'h7	'h7	'h0
	MSI & Clock Power Mgmt Enable	8'h29	8'h29	8'h29	'h0
	Interrupt Pin	'h4	'h4	'h4	'h0

5.3 Serial Port

Serial port is a full-duplex device which uses separate lines for transmitting and receiving data to send and receive data at the same time. When a character is about to be transmitted, a start bit is sent. A start bit has a value of 0 (also called a space state). Thus, when the line switches from a value of 1 to a value of 0, the receiver is alerted that a data character is about to be sent. Once the start bit has been sent, the transmitter sends the actual data bits. There may either be 5, 6, 7 or 8 data bits, depending on the number you have selected. Both receiver and the transmitter must agree on the number of data bits, as well as the baud rate.

Notice, when only 7 data bits are employed, and cannot send ASCII values greater than 127. Likewise, using 5 bits limits the highest possible value to 31. After the data has been transmitted, a stop bit is sent. A stop bit has a value of 1 or a mark state and it can be detected correctly even if the previous data bit also had a value of 1. This is accomplished by the stop bit's duration. Stop bits can be 1, 1.5 or 2 bit periods in length.

Besides the synchronization provided by the use of start and stop bits, an additional bit called a parity bit may optionally be transmitted along with the data. A parity bit affords a small amount of error checking, to help detect data corruption that might occur during transmission. You can choose even parity, odd parity, mark parity, space parity or none at all. When even or odd parity is being used, the number of marks (logical 1 bit) in each data byte is counted, and a single bit is transmitted following the data bits to indicate whether the number of 1 bit just sent is even or odd.

The Serial port implements the Enhanced mode and all of its features and it is backward compatible to the other modes. Each serial port controller has register logic controlling baud rates (50 bps – 16 Mbps), stop bits, parity bit settings. In addition, this block has serial port specific registers for interrupts, line status, line control features which can be accessed by software. The serial port controllers can interface to external RS232/RS422/RS485 transceivers. All the modes have some extra features to enhance the performance.

The different modes of serial port are:

- UART 16C450(Default Mode)
- UART 16C550
- UART 16C550 Ex
- UART 16C650 Mode
- MosChip Enhanced Mode

UART 16C450 Mode

This mode of operation is also known as Byte mode of operation. After the power on reset, the default UART operating mode is set to 16C450.

UART 16C550 Mode

After the hardware reset, writing a 1 to FCR [0] register increases the FIFO size to 16, providing the compatibility with 16C550 type of devices. This mode of operation also does not have any enhanced features. Support all the features of 450 mode.

UART 16C550 Extended Mode

After the hardware reset, writing a 1 to FCR [0] and enabling the FIFOSEL signal the UART goes in to the 16C550 extended mode. In this mode the FIFO size increases to 128 from 16. This mode of operation also does not have any enhanced features. Support all the features of 16C550 mode.

UART 16C650 Mode

UART is compatible with 16C650 mode when the MXR [4] is set, i.e. the device is in the enhanced mode. In 16C650 mode, software drivers usually put the device in the enhanced mode. Running 16C650 drivers on the UART channel will result in 16C650 compatibility mode with 128 deep FIFOs, as long as the FCR [0] register is set. Support all the features of 16C550 Ex mode.

MosChip Enhanced Mode

The additional features offered in MosChip Enhanced mode generally apply when the UART is in enhanced mode. Flow control and High baud rate support can be achieved in this mode of operation. In enhanced mode, the FIFO size is 128 bytes. MosChip Enhanced mode specific features are enabled using the additional control register ACR.

5.4 Parallel Port

This interface is a bidirectional extension of the existing PC parallel interface. The bidirectional communication occurs using the signals in the existing interface. The interface supports a number of distinct communication modes, and the interpretation of interface signals depends on the current mode. The different modes are Compatibility mode, Nibble mode, Byte mode, ECP mode and EPP modes. Not all devices support all communication modes. A mechanism is provided for the host and peripheral to negotiate the mode to be used for data transfers and to renegotiate as needed. In the Nibble or Byte Mode, the host requests a reverse channel transfer, and the peripheral responds by indicating whether there is data to be sent. If no data is ready to be sent, the host can enter the reverse idle phase, in which the peripheral will indicate to the host when data becomes available. In the ECP or EPP Modes, the host may read or write address or data information from or to the peripheral. The host may return the link to the Compatibility Mode whenever the interface is in a valid state, which is uniquely specified for each mode. Each of these arrangements gives the interface at least two separate channels, one in each direction. Having two channels allows peripheral-to-host data to be transferred even when the host-to-peripheral data channel is blocked.

Compatibility Mode

This is an asynchronous data transfer mode, byte-wide forward (host-to-peripheral) channel with data and status lines. This Mode provides host-to-peripheral communication in a manner compatible with the traditional unidirectional interface. This Mode is backward compatible with many existing devices, including the PC parallel port, and is the base mode common to all compliant interfaces. In this Mode, the host sends 8 bits to the peripheral over the interface data signals. An interlocked handshake replaces the minimum timing requirements of Compatibility Mode.

Compatibility Mode phases

Compatibility Mode forward data transfer phase begins when the host asserts nStrobe and ends following data holds time and nStrobe de-assertion. (Note that the host is not free to send the next data byte until the peripheral acknowledges the transfer using nAck.) The host may not initiate negotiation to a new operating mode until the interface returns to Compatibility Mode forward idle phase.

Compatibility Mode forward idle phase begins when the interface is in Compatibility Mode and no data transfer is in progress, the host may initiate a data transfer in Compatibility Mode or may initiate negotiation to a new operating mode.

Nibble Mode

This is an asynchronous data transfer mode, reverse (peripheral-to-host) channel, under control of the host. Nibble Mode is used with Compatibility Mode to implement a bidirectional channel. These two modes cannot be active simultaneously. In Nibble Mode, peripheral-to-host data bytes are sent as two sequential nibbles on the parallel port status lines.

Nibble Mode phases

- Reverse data transfer phase: Data transfers from the peripheral to the host
- Reverse host busy data available phase: The peripheral has data to transmit
- Reverse host busy data not available phase: The peripheral has no data to transmit
- Reverse idle phase: No data transfer, and the host is waiting for peripheral data. When data are available, the peripheral will cause the interface to go to the reverse interrupt phase
- Reverse interrupt phase: A phase that provides the mechanism for the peripheral to alert the host that it has data to transfer. While in this phase, the host may cause the interface to go to the termination phase

Byte Mode

This is an asynchronous, byte-wide reverse (peripheral-to-host) channel using the eight data lines of the interface for data and the control/status lines for handshaking. Byte Mode is used with Compatibility Mode to implement a bidirectional channel, with transfer direction controlled by the host when the host and peripheral both support bidirectional use of the data lines. The two modes cannot be active simultaneously.

Byte Mode phases

- Reverse data transfer phase: Data transfers from the peripheral to the host
- Reverse host busy data available phase: The peripheral has data to transmit
- Reverse host busy data not available phase: The peripheral has no data to transmit
- Reverse idle phase: No data transfer, and the host is waiting for peripheral data. When data is available, the peripheral will cause the interface to go to the reverse interrupt phase or reverse to forward phase
- Reverse interrupt phase: A phase that provides the mechanism for the peripheral to alert the host that it has data to transfer. While in this phase, the host may cause the interface to go to the termination phase

Extended Capabilities Port (ECP) Mode

This is an asynchronous byte-wide mode, bidirectional channel. This Mode provides symmetric bidirectional communications without the overhead of changing communication modes. A control line is provided to distinguish between command and data transfers. A command may optionally be used to indicate single-byte data compression or channel address.

ECP mode phases

- ECP setup phase: A phase that sets the interface signals to the correct state for the ECP forward transfer phase. It immediately follows the negotiation phase
- ECP forward transfer phase: The host transfers data or commands to the peripheral using HostClk. The peripheral may indicate its desire to send data to the host by asserting nPeriphRequest
- ECP forward idle phase: No data transfer, the peripheral may indicate its desire to communicate with the host by asserting nPeriphRequest. The host may cause the interface to go to the forward to reverse phase, forward transfer phase, or the termination phase
- ECP forward to reverse phase: The interface change process from the forward direction to the reverse direction
- ECP reverse transfer phase: The peripheral transfer data or commands to the host. The host may interrupt the peripheral, causing the interface to go to the reverse to forward phase
- ECP reverse idle phase: No data transfer. The host may interrupt the peripheral, causing the interface to go to the reverse to forward phase. The peripheral will cause the interface to go to the reverse transfer phase or reverse to forward phase
- ECP reverse to forward phase: The interface change process from the reverse direction to the forward direction

Enhanced Parallel Port (EPP) Mode

This mode is an asynchronous, byte-wide, bidirectional channel controlled by the host device. This Mode provides asymmetric bidirectional data transfer driven by the host device. This mode provides separate address and data cycles over the eight data lines of the interface.

EPP mode phases

- EPP address read phase: The host performs an address read transfer operation
- EPP address write phase: The host performs an address write transfer operation
- EPP data read phase: The host performs a data read transfer operation
- EPP data write phase: The host performs a data write transfer operation
- EPP initial idle phase: A transition phase from negotiation phase to EPP Mode. After a transfer operation (address or data read/write), the interface will enter the idle phase
- EPP idle phase: No address or data transfer is in progress
- EPP termination phase: Host-initiated transition phase in which the interface is changed from EPP Mode to Compatibility Mode

Additional phases

- Initialization phase: A phase that includes both power-on initialization and host-driven interface reset
- Negotiation phase: Signal handshaking to change the signaling method from Compatibility Mode to Nibble, Byte, ECP, or EPP Mode
- Power-on phase: A phase that includes power-on initialization for both devices
- Termination phase: A host-initiated transition phase in which the interface is changed from Nibble, Byte or ECP Mode to Compatibility Mode

5.5 I²C

All I²C devices are connected through two wires: serial data (SDA) and serial clock (SCL). I²C has a master/slave protocol. The master initiates the communication. Since there are only two wires, this protocol includes the extra overhead of the addressing and acknowledgment mechanisms.

Serial Data: The serial data SDA is a bi-directional pin used to transfer addresses and data into and data out of the device. It is an open drain terminal; therefore, the SDA bus requires a pull-up resistor to VCC (typical 10 kΩ for 100 kHz, 2 kΩ for 400 kHz and 1 MHz). For normal data transfer SDA is allowed to change only during SCL low. Changes during SCL high are reserved for indicating the START and STOP conditions.

Serial Clock: The serial clock SCL is a bi-directional pin used to synchronize the data transfer from and to the device.

Address inputs: The address inputs A0, A1, A2 are used by the slave for multiple device operations. The logic levels on these inputs are compared with the corresponding bits in the slave address.

EEPROM Access

I²C operation is performed at address: GPIO_I2C_BAR5+0xC8.

The 32-bit information sent at this address is specified in tsif_cfg_data_in register. The details of this register are as follows:

Bits	Type	Reset	Name	Description
[31]	RW	0	tsif_cfg_data_in	If '1' specifies write to EPROM. If '0' specifies read from EEPROM.
[30:25]	RW	0	tsif_cfg_data_in	specifies I ² C device address
[24]	RW	0	tsif_cfg_data_in	specifies I ² C address is 8-bit/16-bit
[23:8]	RW	0	tsif_cfg_data_in	specifies I ² C address
[7:0]	RW	0	tsif_cfg_data_in	specifies 8-bit data

5.6 PM Control

This block implements power management. The chip works in three PCIe based power states (1) D0, (2) D3 Hot and (3) D3 Cold.

There is NO power plane separation between Vaux and VCC. In D3 Cold, the chip VCC should be powered from Vaux to support remote wake up.

Further power save is achieved through disabling the blocks which are not selected. A set of register bits, Port_dis_reg[7:0], are provided to disable each block independently. Port_dis_reg is mapped to BAR4 + 0x69 and can access through all functions and its bit map is given below

Register Bit	Control	Description
port_dis_reg[0]	pp_disable	1: Disables Parallel Port
port_dis_reg[1]	Serial Port transceiver shut down polarity	1: Active Low 0: Active High
port_dis_reg[2]	Serial Port transceiver shut down enable	1: Enables transceiver shut down when in power save mode 0: disables transceiver shut down
port_dis_reg[3]	sp1_disable	1 : Disables Serial Port 1
port_dis_reg[4]	sp2_disable	1 : Disables Serial Port 2
port_dis_reg[5]	sp3_disable	1 : Disables Serial Port 3
port_dis_reg[6]	sp4_disable	1 : Disables Serial Port 4
port_dis_reg[7]	disp_disable	1 : Reserved

5.7 Cascade Interface

Cascade Interface is a generic IO expansion bus that is based on MosChip proprietary interface protocol. The cascade interface allows interconnecting any MosChip device supporting the cascade interface protocol.

A standalone MCS9900 device supports up to 4 serial ports and one parallel port over PCIe. When two MCS9900 devices are interconnected through the cascade interface, the number of peripheral ports can be doubled. The combined MCS9900 devices are serviced through a single PCIe on the primary MCS9900, and the ports can be expanded using one of the following configurations.

- 8 serial ports
- 6 serial ports and 1 parallel port
- 4 serial ports and 2 parallel ports

In cascaded configuration, one of the MCS9900 chips works as primary and the other secondary. The primary chip implements 4-function PCIe endpoint. The PCIe core of secondary chip is disabled. Only cascade and serial port logic is active in secondary chip

The cascade interface also allows connecting any other chip that's designed as per this interface. When a non MCS9900 chip is connected, functions 0, 1 and 2 are used by primary and functions 3 and 4 are available to be used by secondary chip.

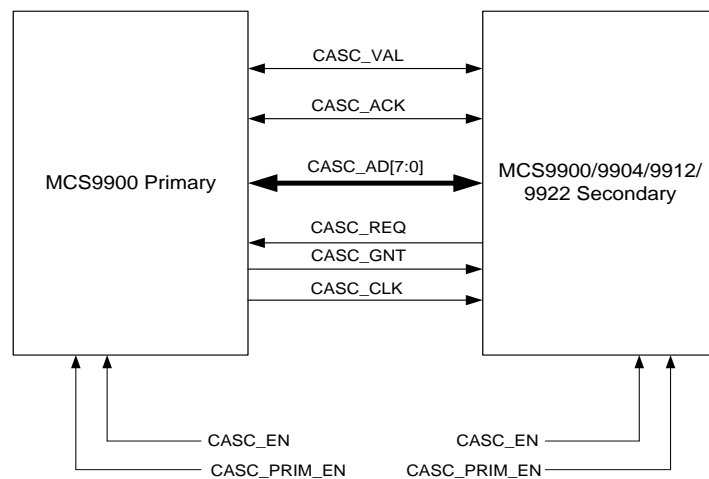

Cascade Interface between Primary and Secondary Devices

In cascade mode, the PCIe endpoint interface is available through the primary MCS9900 device only. The PCIe is disabled on the cascaded secondary device and its access is limited through the cascade interface only. The primary MCS9900 implements a 4-function PCIe end point such that each of these 4 functions serve two serial port, one from primary chip and the other from secondary chip. The following tables list the functions and the corresponding BAR mapping.

BAR Mapping for 8 Serial mode PCIe functions

BAR	Function 0	Function 1	Function 2	Function 3
BAR0	SP1 I/O	SP2 I/O	SP3 I/O	SP4 I/O
BAR1	SP1 Mem	SP2 Mem	SP3 Mem	SP4 Mem
BAR2	-	-	-	-
BAR3	SP5 I/O	SP6 I/O	SP7 I/O	SP8 I/O
BAR4	SP5 Mem	SP6 Mem	SP7 Mem	SP8 Mem
BAR5	GPIO/I2C	GPIO/I2C	GPIO/I2C	GPIO/I2C

BAR Mapping for 6-Serial 1-Parallel mode PCIe functions

BAR	Function 0	Function 1	Function 2	Function 3
BAR0	SP1 I/O	SP2 I/O	SP3 I/O	SP4 I/O
BAR1	SP1 Mem	SP2 Mem	SP3 Mem	SP4 Mem
BAR2	-	-	-	-
BAR3	SP5 I/O	SP6 I/O	PP1 I/O	-
BAR4	SP5 Mem	SP6 Mem	PP1 I/O	-
BAR5	GPIO/I2C	GPIO/I2C	PP1 Mem	GPIO/I2C

BAR Mapping for 4-Serial 2-Parallel mode PCIe functions

BAR	Function 0	Function 1	Function 2
BAR0	SP1 I/O	SP2 I/O	PP1 I/O
BAR1	SP1 Mem	SP2 Mem	PP1 I/O
BAR2	-	-	PP1 Mem
BAR3	SP3 I/O	SP4 I/O	PP2 I/O
BAR4	SP3 Mem	SP4 Mem	PP2 I/O
BAR5	GPIO/I2C	GPIO/I2C	PP2 Mem

BAR Mapping for 2 Serial & Other Secondary device mode PCIe functions

BAR	Function 0	Function 1	Function 2	Function 3
BAR0	SP1 I/O	SP2 I/O	Secondary chip	Secondary chip
BAR1	SP1 Mem	SP2 Mem	Secondary chip	Secondary chip
BAR2	-	-	Secondary chip	Secondary chip
BAR3	-	-	Secondary chip	Secondary chip
BAR4	-	-	Secondary chip	Secondary chip
BAR5	GPIO/I2C	GPIO/I2C	-	GPIO/I2C

1 Serial, 1 Parallel & Other Secondary device mode PCIe functions

BAR	Function 0	Function 1	Function 2	Function 3
BAR0	SP1 I/O	PP I/O	Secondary chip	Secondary chip
BAR1	SP1 Mem	PP I/O	Secondary chip	Secondary chip
BAR2	-	PP Mem	Secondary chip	Secondary chip
BAR3	-	-	Secondary chip	Secondary chip
BAR4	-	-	Secondary chip	Secondary chip
BAR5	GPIO/I2C	GPIO/I2C	-	GPIO/I2C

Cascade clock connection

In order to meet timing on cascade interface, it is required to send cascade clock out from primary (through CASC_CLK pin) and bring it back using SCAN_MODE pins to both primary and secondary chips through an external onboard connection. Figure below shows the required connections.

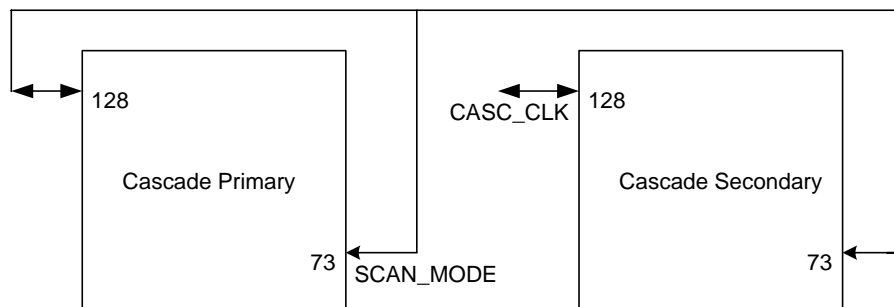

5.8 Clocks and Resets

MCS9900 requires two input clocks. One input clock is sourced from the PCIe connector and the second input clock is sourced from the external crystal. PCIe PHY uses the 100 MHz differential clock from the PCIe connector to generate the internal 125MHz clock. Clock from crystal is used to generate clocks for serial ports, parallel ports.

Crystal Requirement

MCS9900 requires one crystal. This crystal is used to generate serial port clocks. Preferable input frequency is 30 MHz because it allows generating the serial port clock frequency of 96 MHz.

Crystal	Frequency
For Serial Ports	30 MHz

Internal PLLs

MCS9900 uses two PLLs to generate the necessary internal clocks for the device operation. The usage of the PLLs is listed in the following Table.

PLL	Input Frequency	Output Frequency	Used By
PLL1	30 MHz	96 MHz	Serial Port

POR Cell

A POR Cell is used to isolate reset of EEPROM from PCIe reset. It is observed that some PCIe hosts issue multiple PCIe resets. EEPROM read starts automatically on power up. If PCIe reset is used for EEPROM state machines, it causes abrupt resets to EEPROM state machine and may cause it to hang. To avoid this, EEPROM logic is being reset on power-on only. PCIe resets do not affect EEPROM logic.

Side effect of this is that EEPROM logic and the register set that's loaded from EEPROM holds the values till power cycle. If there is a change in EEPROM or EEPROM data, it is required to power cycle in order to get the new values.

5.9 GPIO

There are 6 General Purpose Input/Output pins. Additional 2 GPIO pins are available when parallel port is not enabled. All the GPIO pins are interrupt capable. Each GPIO can be configured independent of all other GPIO. The GPIOs allow data input and IRQ generation.

The GPIO Interface register layout can be configured so that the direction and level of each I/O can be configured using either a single register for all I/Os, or discrete registers for each I/O.

6 EEPROM Contents Layout

MCS9900 requires an I²C EEPROM (in 16 bit organization mode) for configuring various sub configurations and device parameters.

EEPROM Address	Parameter	MCS9900 (4S)	MCS9900 (2S1P)
0	Signature ID_F0[7:0]	10	10
1	Signature ID_F0[15:8]	97	97
2	Vendor ID_F0[7:0]	10	10
3	Vendor ID_F0[15:8]	97	97
4	Device ID_F0[7:0]	50	50
5	Device ID_F0[15:8]	99	99
6	Revision ID	00	00
7	Programmable IF_F0	00	00
8	Sub Class Code_F0	01	01
9	Class Code_F0	03	03
10	Sub System Vendor ID_F0[7:0]	00	00
11	Sub System Vendor ID_F0[15:8]	A0	A0
12	Sub System Device ID_F0[7:0]	00	00
13	Sub System Device ID_F0[15:8]	40	40
14	PM_Cap_F0[7:0]	0F	0F
15	PM_Cap_F0[15:8]	06	06
16	Extended capabilities F0[7:0]	01	01
17	Extended capabilities F0[15:8]	00	00
18	Device Capabilities F0[7:0]	02	02
19	Device Capabilities F0[15:8]	83	83
20	Link_Capabilities F0[7:0]	07	07
21	msi_and_clk_pwr_mgmt_en F0[7:0]	01	01
22	Interrupt pin F0	01	01
23	Vendor ID_F1[7:0]	10	10
24	Vendor ID_F1[15:8]	97	97
25	Device ID_F1[7:0]	50	50
26	Device ID_F1[15:8]	99	99
27	Programmable IF_F1	02	02
28	Sub Class Code_F1	00	00
29	Class Code_F1	07	07
30	Sub System Vendor ID_F1[7:0]	00	00
31	Sub System Vendor ID_F1[15:8]	A0	A0
32	Sub System Device ID_F1[7:0]	00	00
33	Sub System Device ID_F1[15:8]	10	10
34	PM_Cap_F1[7:0]	0F	0F
35	PM_Cap_F1[15:8]	06	06
36	Extended capabilities F1[7:0]	01	01
37	Extended capabilities F1[15:8]	00	00
38	Device Capabilities F1[7:0]	02	02
39	Device Capabilities F1[15:8]	83	83
40	Link_Capabilities F1[7:0]	07	07

EEPROM Address	Parameter	MCS9900 (4S)	MCS9900 (2S1P)
41	msi_and_clk_pwr_mgmt_en F1[7:0]	19	19
42	Interrupt pin F1	02	02
43	Vendor ID_F2[7:0]	10	10
44	Vendor ID_F2[15:8]	97	97
45	Device ID_F2[7:0]	50	50
46	Device ID_F2[15:8]	99	99
47	Programmable IF_F2	02	02
48	Sub Class Code_F2	00	00
49	Class Code_F2	07	07
50	Sub System Vendor ID_F2[7:0]	00	00
51	Sub System Vendor ID_F2[15:8]	A0	A0
52	Sub System Device ID_F2[7:0]	00	00
53	Sub System Device ID_F2[15:8]	10	10
54	PM_Cap_F2[7:0]	0F	0F
55	PM_Cap_F2[15:8]	06	06
56	Extended capabilities F2[7:0]	01	01
57	Extended capabilities F2[15:8]	00	00
58	Device Capabilities F2[7:0]	02	02
59	Device Capabilities F2[15:8]	83	83
60	Link_Capabilities F2[7:0]	07	07
61	msi_and_clk_pwr_mgmt_en F2[7:0]	19	19
62	Interrupt pin F2	03	03
63	Vendor ID_F3[7:0]	10	10
64	Vendor ID_F3[15:8]	97	97
65	Device ID_F3[7:0]	50	50
66	Device ID_F3[15:8]	99	99
67	Programmable IF_F3	02	03
68	Sub Class Code_F3	00	01
69	Class Code_F3	07	07
70	Sub System Vendor ID_F3[7:0]	00	00
71	Sub System Vendor ID_F3[15:8]	A0	A0
72	Sub System Device ID_F3[7:0]	00	00
73	Sub System Device ID_F3[15:8]	10	20
74	PM_Cap_F3[7:0]	0F	0F
75	PM_Cap_F3[15:8]	06	06
76	Extended capabilities F3[7:0]	01	01
77	Extended capabilities F3[15:8]	00	00
78	Device Capabilities F3[7:0]	02	02
79	Device Capabilities F3[15:8]	83	83
80	Link_Capabilities F3[7:0]	07	07
81	msi_and_clk_pwr_mgmt_en F3[7:0]	19	19
82	Interrupt pin F3	04	04
83	Vendor ID_F4[7:0]	10	FF
84	Vendor ID_F4[15:8]	97	FF
85	Device ID_F4[7:0]	50	FF
86	Device ID_F4[15:8]	99	FF

EEPROM Address	Parameter	MCS9900 (4S)	MCS9900 (2S1P)
87	Programmable IF_F3	02	00
88	Sub Class Code_F3	00	00
89	Class Code_F3	07	00
90	Sub System Vendor ID_F4[7:0]	00	00
91	Sub System Vendor ID_F4[15:8]	A0	00
92	Sub System Device ID_F4[7:0]	00	00
93	Sub System Device ID_F4[15:8]	10	00
94	PM_Cap_F4[7:0]	0F	00
95	PM_Cap_F4[15:8]	06	00
96	Extended capabilities F4[7:0]	01	00
97	Extended capabilities F4[15:8]	00	00
98	Device Capabilities F4[7:0]	02	00
99	Device Capabilities F4[15:8]	83	00
100	Link_Capabilities F4[7:0]	07	00
101	msi_and_clk_pwr_mgmt_en F4[7:0]	19	00
102	Interrupt pin F4	04	00
103	INTA Mask register	01	01
104	INTB Mask Register	02	02
105	INTC Mask Register	04	04
106	INTD Mask Register	18	08
107	Port Disable Register	02	02
108	Reserved	70	30
109	Serial port1 Function number	01	01
110	Serial port2 Function number	02	02
111	Serial port3 Function number	03	03
112	Serial port4 Function number	04	04
113	Reserved	00	00
114 to 170	bar3,bar4 incase of 3rd party modes	--	--

Extended Modes through EEPROM

Different product configurations can be selected for MCS9900 through 4 mode select pins. Also, MCS9900 can be configured as a primary device to cascade with secondary device on the cascade interface. MCS9900 can be configured to 4 functional modes through mode select pins and primary/secondary select pins without using EEPROM. By using external EEPROM, more functional configurations can be derived with MCS9900. Few such configurations are listed below.

MCS9900 Possible Product Configuration	EEPROM Required?	Mode Selection at System Level?
1 Serial Port	Yes	Yes
2 Serial Ports	Yes	Yes
3 Serial Ports	Yes	Yes
4 Serial Ports	No	Yes
1 Parallel Port	Yes	Yes
1 Serial Port + 1 Parallel Port	Yes	Yes
2 Serial Port + 1 Parallel Port	No	Yes
8 Serial Ports (Cascade)	No	Yes
7 Serial Ports (Cascade)	Yes	Yes
6 Serial Ports (Cascade)	Yes	Yes
5 Serial Ports (Cascade)	Yes	Yes
4 Serial Ports + 2 Parallel Ports (Cascade)	Yes	Yes
3 Serial Ports + 2 Parallel Port (Cascade)	Yes	Yes
2 Serial Ports + 2 Parallel Ports (Cascade)	Yes	Yes
6 Serial Ports + 1 Parallel Port (Cascade)	No	Yes

MCS9904 Possible Product Configuration	EEPROM Required?	Mode Selection at System Level?
1 Serial Port	Yes	No
2 Serial Ports	Yes	No
3 Serial Ports	Yes	No
4 Serial Ports	No	No

MCS9901 Possible Product Configuration	EEPROM Required?	Mode Selection at System Level?
1 Serial Port	Yes	No
2 Serial Ports	Yes	No
1 Serial Port + 1 Parallel Port	Yes	No
2 Serial Port + 1 Parallel Port	No	No

MCS9922 Possible Product Configuration	EEPROM Required?	Mode Selection at System Level?
1 Serial Port	Yes	No
2 Serial Ports	No	No

7 Electrical Specifications

Absolute Maximum Ratings

Symbol	Description	Rating	unit
V _{CCK}	1.2V Digital Power Supply	-0.3 to 1.44	V
V _{CC12A}	1.2V Analog Power Supply	-0.3 to 1.44	V
V _{CC33IO}	3.3V Digital Power Supply	-0.3 to 4.0	V
V _{CC33A}	3.3V Analog Power Supply	-0.3 to 4.0	V
T _{stg}	Storage temperature	-40 to 150	°C
T _o	Operating temperature	0 to 85	°C
T _j	Junction temperature	0 to 125	°C
ESD HBM	(MIL-STD 883E Method 3015-7 Class 2)	2000	V
ESD MM	(JEDEC EIA/JESD22 A115-A)	200	V
CDM	(JEDEC JESD22 C101-A)	500	V
θ _{JA}	Thermal Resistance of Junction to Ambient	52.7	C/W
θ _{JC}	Thermal Resistance of Junction to Case	17.8	C/W
Ψ _{JT}	Junction to Top of the Package Characterization Parameter	0.54	C/W

C/W – °C per Watt , For Still Air Condition

Recommended Operating Conditions

Symbol	Description	Min	Typ	Max	units
VCCK	1.2V Digital Power Supply	1.08	1.2	1.32	V
VCC12A	1.2V Analog Power Supply	1.08	1.2	1.32	V
VCC33IO	3.3V Digital Power Supply	2.97	3.3	3.63	V
VCC33A	3.3V Analog Power Supply	2.97	3.3	3.63	V
To	Operating temperature	0	25	85	°C
Tj	Junction temperature	0	25	125	°C
I _{1.2VD}	Current in 1.2V Digital Power Supply		65		mA
I _{1.2VA}	Current in 1.2V Analog Power Supply		40		mA
I _{3.3VD}	Current of 3.3V Digital Power Supply		20		mA
I _{3.3VA}	Current in 3.3V Analog Power Supply		75		mA

8 Mechanical Dimensions

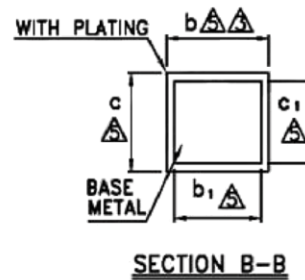
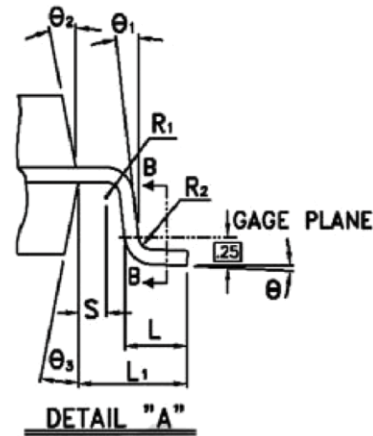
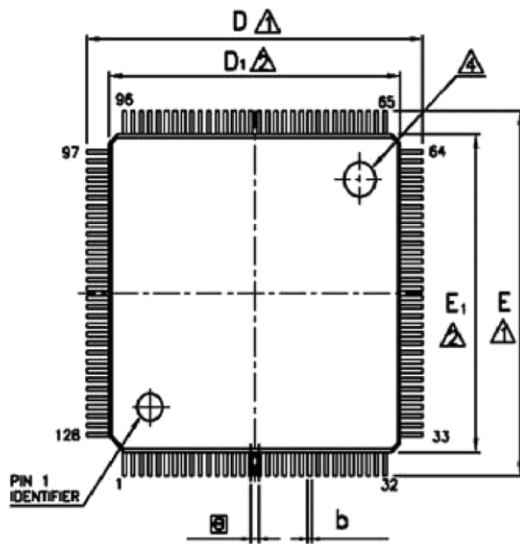

Symbol	Dimension in mm		
	Min	Norm	Max
A	—	—	1.60
A ₁	0.05	—	—
A ₂	1.35	1.40	1.45
b	0.13	0.18	0.23
b ₁	0.13	0.16	0.19
c	0.09	—	0.20
c ₁	0.09	—	0.16
D	15.85	16.00	16.15
D ₁	13.90	14.00	14.10
E	15.85	16.00	16.15
E ₁	13.90	14.00	14.10
⊙	0.40 BSC		
L	0.45	0.60	0.75
L ₁	1.00 REF		
R ₁	0.08	—	—
R ₂	0.08	—	0.20
S	0.20	—	—
θ	0°	3.5°	7°
θ ₁	0°	—	—
θ ₂	12°TYP		
θ ₃	12°TYP		

NOTE :

- ▲ TO BE DETERMINED AT SEATING PLANE .
- ▲ DIMENSIONS D₁ AND E₁ DO NOT INCLUDE MOLD PROTRUSION. D₁ AND E₁ ARE MAXIMUM PLASTIC BODY SIZE DIMENSIONS INCLUDING MOLD MISMATCH.
- ▲ DIMENSION b DOES NOT INCLUDE DAMBAR PROTRUSION. DAMBAR CAN NOT BE LOCATED ON THE LOWER RADIUS OF THE FOOT.
- ▲ EXACT SHAPE OF EACH CORNER IS OPTIONAL.
- ▲ THESE DIMENSIONS APPLY TO THE FLAT SECTION OF THE LEAD BETWEEN 0.10 mm AND 0.25 mm FROM THE LEAD TIP.
- ▲ A₁ IS DEFINED AS THE DISTANCE FROM THE SEATING PLANE TO THE LOWEST POINT OF THE PACKAGE BODY.
- 7. CONTROLLING DIMENSION : MILLIMETER.
- 8. REFERENCE DOCUMENT : JEDEC MS-026.