

Ceramic Low Pass Filter

50Ω DC⁽¹⁾ to 95 MHz

LFCN-95+ LFCN-95



CASE STYLE: FV1206
PRICE: \$3.99 ea. QTY (20)

Maximum Ratings

Operating Temperature	-55°C to 100°C
Storage Temperature	-55°C to 100°C
RF Power Input*	8.5W max. at 25°C

* Passband rating, derate linearly to 3.5W at 100°C ambient. Permanent damage may occur if any of these limits are exceeded.

Pin Connections

RF IN	1
RF OUT	3
GROUND	2,4

Outline Drawing

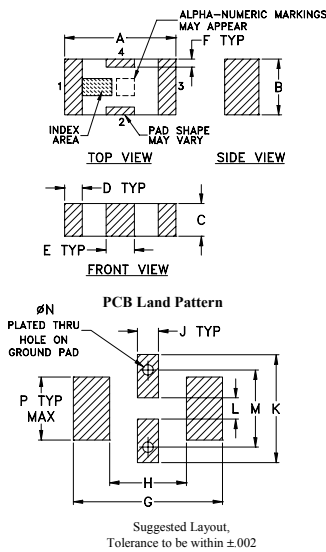

Outline Dimensions (inch)

A	B	C	D	E	F	G
.126	.063	.037	.020	.032	.009	.169
3.20	1.60	0.94	0.51	0.81	0.23	4.29

H	J	K	L	M	N	P	wt
.087	.024	.122	.024	.087	.012	.071	grams
2.21	0.61	3.10	0.61	2.21	0.30	1.80	.020

Demo Board MCL P/N: TB-270
Suggested PCB Layout (PL-137)

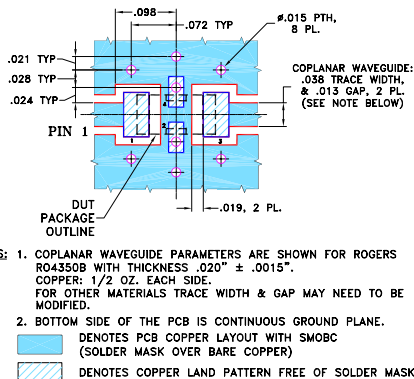

Features

- excellent power handling, 8.5W
- small size
- 7 sections
- temperature stable
- LTCC construction
- protected by U.S. Patent 6,943,646

Applications

- harmonic rejection
- VHF/UHF transmitters/receivers

Electrical Specifications⁽¹⁾ at 25°C

Parameter	F#	Frequency (MHz)	Min.	Typ.	Max.	Unit	
Pass Band	Insertion Loss	DC-F1	DC-95	—	—	1.0	dB
	Freq. Cut-Off	F2	165	—	3.0	—	dB
	VSWR	DC-F1	DC-95	—	1.2	—	:1
Stop Band	Rejection Loss	F3	230	20	—	—	dB
		F4-F5	255-1600	—	40	—	dB
	VSWR	F6	4500	—	20	—	dB
		F3-F6	230-4500	—	20	—	:1

(1) Coupling capacitors at input and output are recommended for use in applications that require DC isolation of input to output port or either port to ground.

Typical Frequency Response

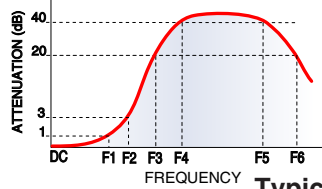

Electrical Schematic



Typical Performance Data at 25°C

Frequency (MHz)	Insertion Loss (dB)	VSWR (:1)
1.00	0.21	1.05
95.00	0.83	1.13
165.00	3.13	1.74
180.00	5.49	2.18
220.00	24.23	3.74
230.00	32.25	4.26
250.00	42.20	5.34
410.00	56.13	19.54
700.00	58.51	62.05
1235.00	48.10	78.97
1600.00	47.15	72.39
2000.00	45.25	75.53
2500.00	32.94	64.35
4500.00	25.30	49.64
5000.00	24.17	38.61

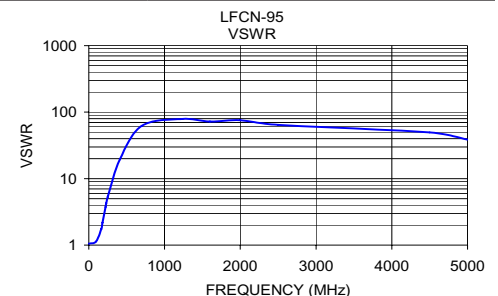
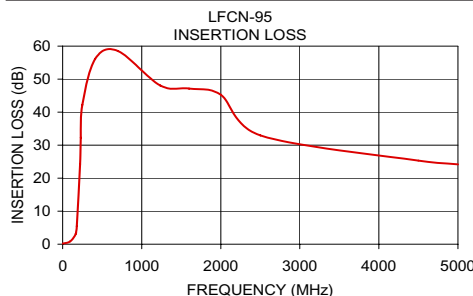

Mini-Circuits®
ISO 9001 ISO 14001 AS 9100 CERTIFIED
The Design Engineers Search Engine
IF/RF MICROWAVE COMPONENTS

For detailed performance specs & shopping online see web site

P.O. Box 350166, Brooklyn, New York 11235-0003 (718) 934-4500 Fax (718) 332-4661 Provides ACTUAL Data Instantly at minicircuits.com

Notes: 1. Performance and quality attributes and conditions not expressly stated in this specification sheet are intended to be excluded and do not form a part of this specification sheet. 2. Electrical specifications and performance data contained herein are based on Mini-Circuit's applicable established test performance criteria and measurement instructions. 3. The parts covered by this specification sheet are subject to Mini-Circuit's standard limited warranty and terms and conditions (collectively, "Standard Terms"); Purchasers of this part are entitled to the rights and benefits contained therein. For a full statement of the Standard Terms and the overall limitations and conditions thereon, please visit Mini-Circuit's website at www.minicircuits.com

REV. G
M125148
LFCN-95
ED11960/3
RVN/AD/CP/AM
110819