

THERMAL CUTOUT

Current-sensitive plus thermal protection for coils and windings

FEATURES

- broad product range for all types of application
- small size
- high switching capacity
- minimal contact resistance
- temperature and current sensitive
- highly responsive

CD79 F

DESCRIPTION

This device is a **thermal cutout**, providing over-temperature protection. A thermally sensitive bimetal snap-element switches when it reaches a pre-set response temperature or a fixed current level, opening the circuit. Current flows through the bimetal element, giving a combination of temperature- and current- protection.

Heat transfer occurs from all sides through convection, radiation or conduction in gaseous or solid media. The rhomboid shape conducts heat directly onto the bimetal snap-element, thus allowing its use as a surface temperature cutout.

APPLICATIONS

Over-temperature protection and, under certain conditions, temperature control of electrical machinery and equipment.

INSTALLATION NOTES

When installing the cutout, good heat transfer must be ensured. The heat sensitive side of the switch (the base) should be positioned on the heat source. Heat-conducting paste or lacquer improves heat transfer.

Please note that in the standard version the cutout has an electrically live housing, and that when electrically insulated, the cutout's effective switching temperature can be affected by reduced heat transfer through the insulation. This should be borne in mind when selecting the appropriate temperature setting.

With single phase motors, the cutout should switch the mains supply. It will then switch off the motor directly in the case of undesirable heating. A short circuit in the motor will also be broken safely if the resulting current is higher than the cutout rating.

In 3-phase motors, the current should not be switched directly via the mains supply. The cutouts are installed in the windings and connected in series with the magnetic coil of the contactor. The cutouts are connected either singly or collectively via the motor's terminal block to allow connection into the control circuit.



TECHNICAL DATA

Voltage	Current rating ($\cos \varphi = 1,0$, resistive loads)	Life expectancy (switching cycles)
120 V AC 16 V DC 120 V AC 277 V AC	5 A 20 A 22 A 8 A	100.000 10.000 10.000 10.000
contact arrangement normally closed		
Standard contact resistance	< 40 mΩ	
Standard response temperature range	+50 °C to +160 °C	
Standard tolerance	±5 K ±10 K	
Continuous temp. rating of contacts Max. temperature rating	T 180 250 °C	
Standard temperature rating as per leads or wire according to insulation class	A, B, T, H as per response temperature	
Housing material	Stainless steel	
Housing insulation options	U 101 SHB shrunk polyester transparent insulation class B U 105 SSB radiation cross-linked shrink sleeve black, insulation class B U 107 SSH radiation cross-linked shrink sleeve, transparent, insulation class F	
Dielectric strength insulation	P302 2750 V 50–60 Hz P303 3750 V 50–60 Hz P304 4000 V 50–60 Hz	
Approvals received / applied for	UL, VDE, CSA	

TEMPERATURE SET-POINTS / TOLERANCE

Temperatures graduated in °C and K
 Tolerance, see 'Technical Data'
 Plain text numbering of response temperature °C
 Tolerance in K

Switching hysteresis
 Reset interval between 5K and 50K below the response temperature

Rate of temperature change from 0.1K/min to max. 1.0K/min

Insulation retards the cutout's response

Special response and reset temperatures available on request

SEALING

Standard version sealed against lacquer (varnish) and epoxy resin etc

CURRENT SENSITIVITY

This additional feature of the normally closed cutout means that the response temperature decreases at high current loads.
 see graph page 4

LEADS

The temperature rating of the connecting leads covers the nominal response temperature of the cutout as a minimum. It also corresponds to the appropriate insulation class and dielectric strength. Leads or solid wires are available in various lengths, cross-sections and qualities; see special data sheet.

CONNECTIONS

Type	Lead length	Code	Temperature-class VDE	Cross-Section	Coating/insulation	Conductor	Colour
AWG 20	100 ⁻²⁰ mm	L523	B	0,5 mm ²	textile/varnish polyolefine FEP	tinned copper	black
		L531	F	0,5 mm ²		tinned copper	blue
		L528	H	0,5 mm ²		tinned copper	white
AWG 18	100 ⁻²⁰ mm	L560	B	0,75 mm ²	textile/varnish polyolefine silicon PTFE	tinned copper	yellow
		L569	F	0,75 mm ²		tinned copper	blue
		L575	H	0,75 mm ²		tinned copper	white
		L567	C	0,75 mm ²		silvered copper	white

Lead stripping: standard 6mm +/-1mm

a = ends stripped, b = half insulated, c = ends stripped and tinned

VERSIONS

CD79 FA

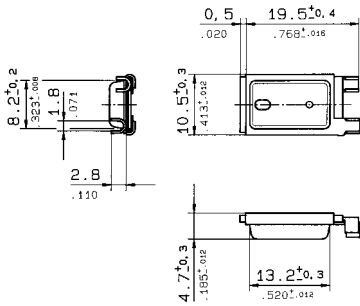

CD70 SA

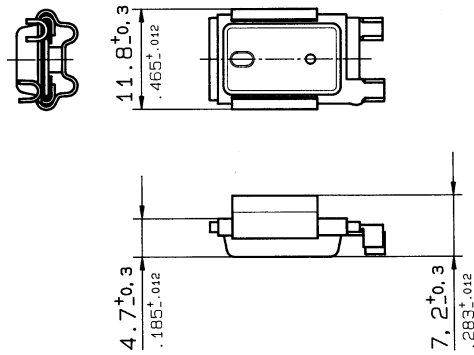

CD79 FB

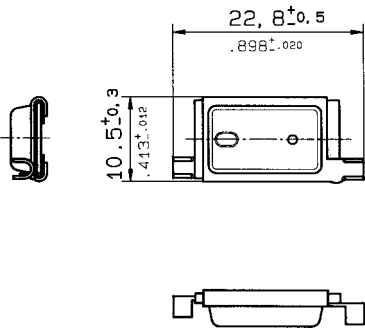

CD70 SB

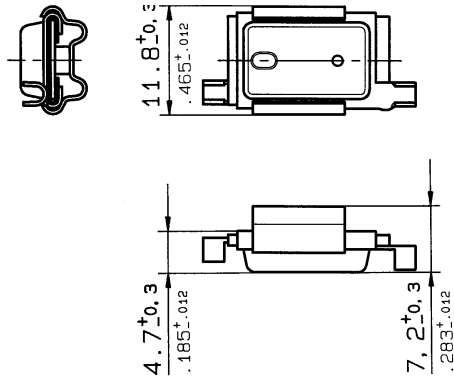

CD79 FG

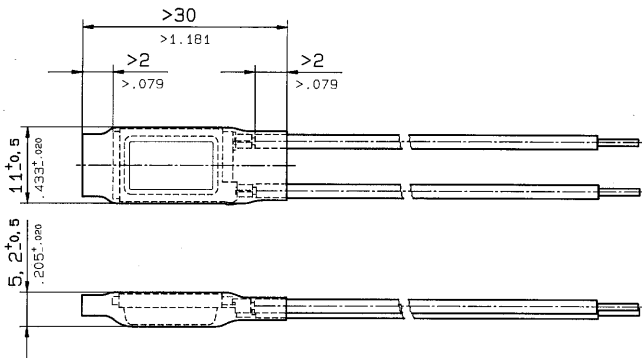

CD70 SG

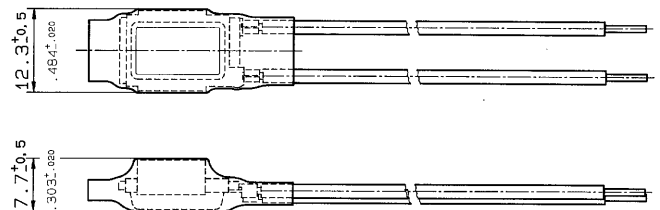

CD79 FH

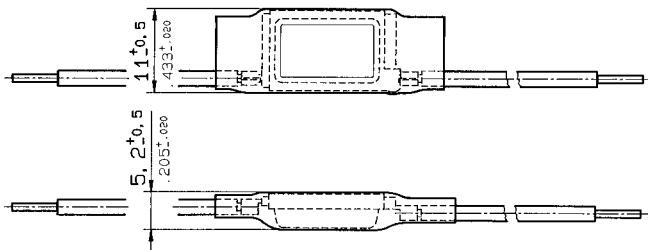

CD70 SH

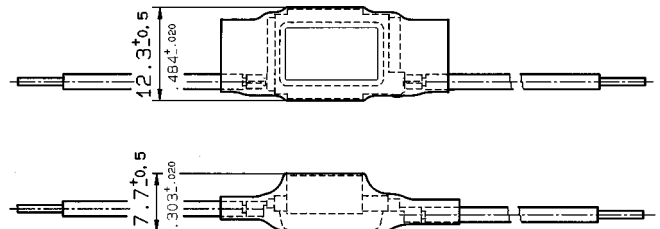

Current vs Temperature

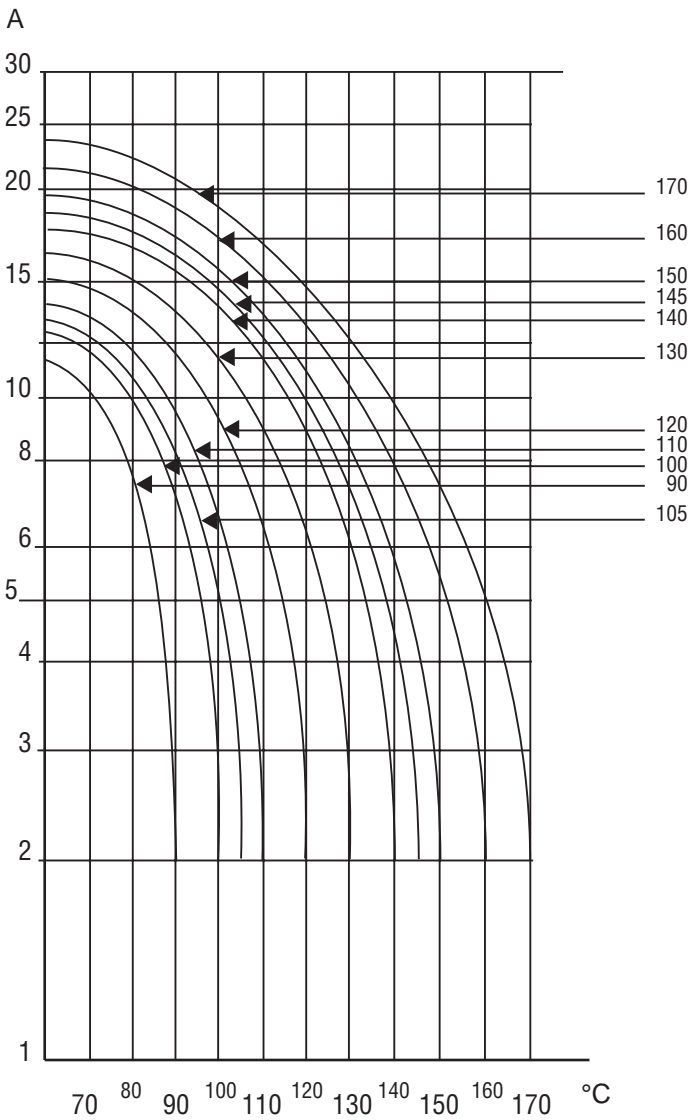

Bimetal resistance 40 ohm
This graph shows mean values

PRODUCT MARKING

Example CD 79 F XXX A B
1 2 3 4 5 6

- 1 CD = Type
- 2 79 = Basic geometric shape
- 3 F = 30 Ohm/cir MIL FT of the bimetal's specific resistance
- 4 XXX = Temperature value, 3 figures between 000 and 160 C
- 5 A = Construction

Code	Connections	Insulation	Leads
A	both one end	no	no
B	opposite ends	no	no
G	both one end	yes	yes
H	opposite ends	yes	yes

- 6 B = For special identification, additional letters upto Z or numerals 1-9 can be used

Response time vs Current

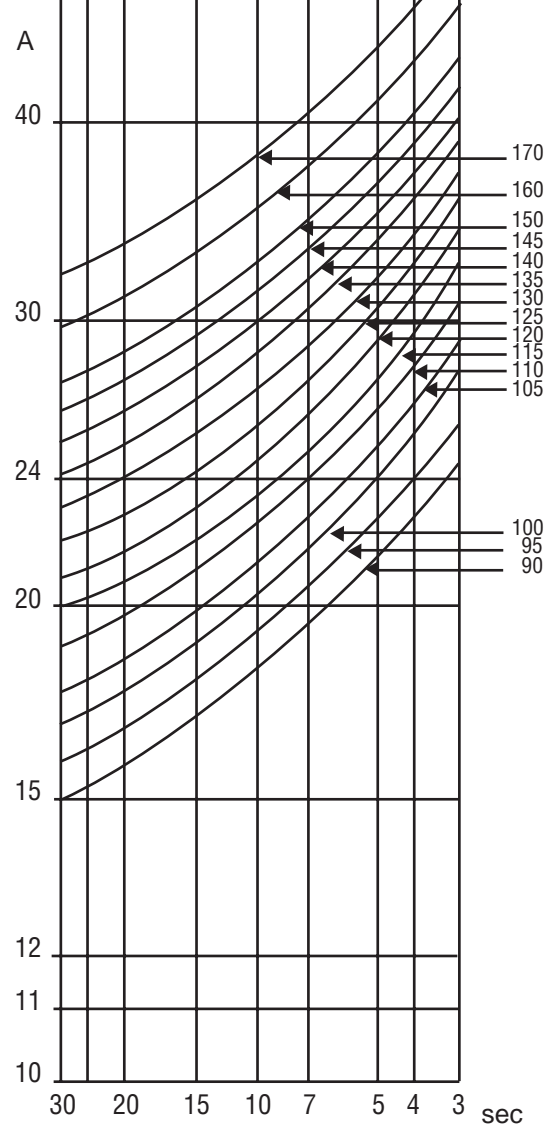

Mean initial cycle response time T 25 C

QUALITY STANDARD

Production item testing
Voltage test, switch function
Nominal switch-off temperature

ORDERING INFORMATION

Quantity	Type	Version	Temperature
5000	CD79F	A	100 °C ±10 K

Technical data and specifications may be altered without prior notice