

SPECIFICATION SHEET FOR SO₂ SENSOR TYPE SO2/SF-400-S

PERFORMANCE CHARACTERISTICS

Nominal Range	0 – 400 ppm
Maximum Overload	1000 ppm
Inboard Filter	To remove H ₂ S and HCl
Expected Operation Life	2 years in air
Output Signal	200 ± 50 nA/ppm
Resolution	0.5 ppm
Temperature Range	- 20 °C to 50 °C
Pressure Range	Atmospheric ± 10%
Pressure Coefficient	No data
T ₉₀ Response Time	< 20 sec
Relative Humidity Range	15 % to 90 % R.H. non-condensing
Typical Baseline Range (pure air, 20°C)	-1 to +1 ppm
Maximum Zero Shift (+20°C to +40°C)	3 ppm
Long Term Output Drift	< 2 % signal loss/month
Recommended Load Resistor	10 Ohm
Bias Voltage	Not required
Repeatability	< 2 % of signal
Output Linearity	Linear

PHYSICAL CHARACTERISTICS

Weight	~ 27 g
Position Sensitivity	None
Storage Life	Six months in container
Recommended Storage Temperature	5 °C – 20 °C
Warranty Period	12 months from date of dispatch

Slim-Size Outline Dimensions

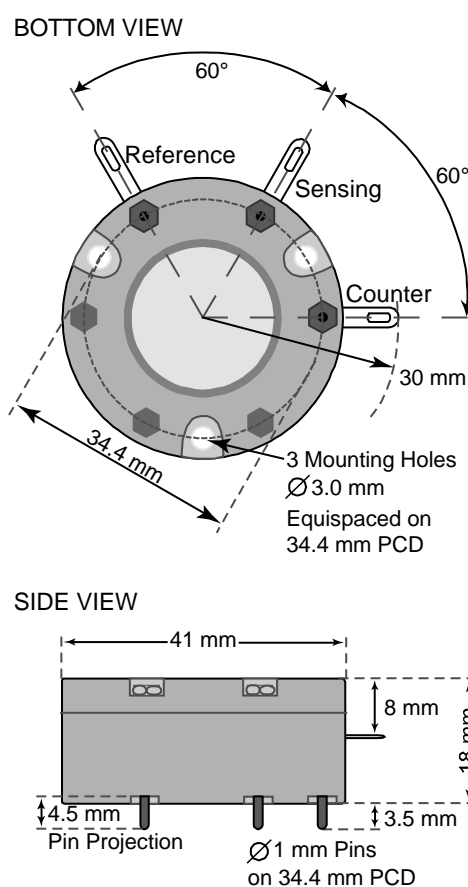

CROSS-SENSITIVITY DATA

Interfering Gas	Concentration	Reading
CO	100 ppm	< 1 ppm
H ₂ S	20 ppm	1 ppm
NO	100 ppm	0 ppm
NO ₂	100 ppm	~ -125 ppm
H ₂	100 ppm	< 1 ppm
Ethylene	100 ppm	0 ppm
HCl	20 ppm	1 ppm

Performance data conditions:
20 °C, 50% RH and 1013 mbar

APPLICATIONS

Stack/ Flue Gas Monitoring
Emission Monitoring

SPECIFICATION SHEET FOR SO₂ SENSOR TYPE SO2/SF-400-S

TEMPERATURE DEPENDENCE

The output of an electrochemical sensor varies with temperature. The graphs below show the variation in output with temperature for this type of sensor. The results are shown in the graphs as a mean for a batch of sensors, along with confidence intervals corresponding to ± 3 times the standard deviation. The sensitivity dependence is expressed as a percentage of the signal at 20 °C. The shift in baseline is shown in ppm referenced to 20 °C.

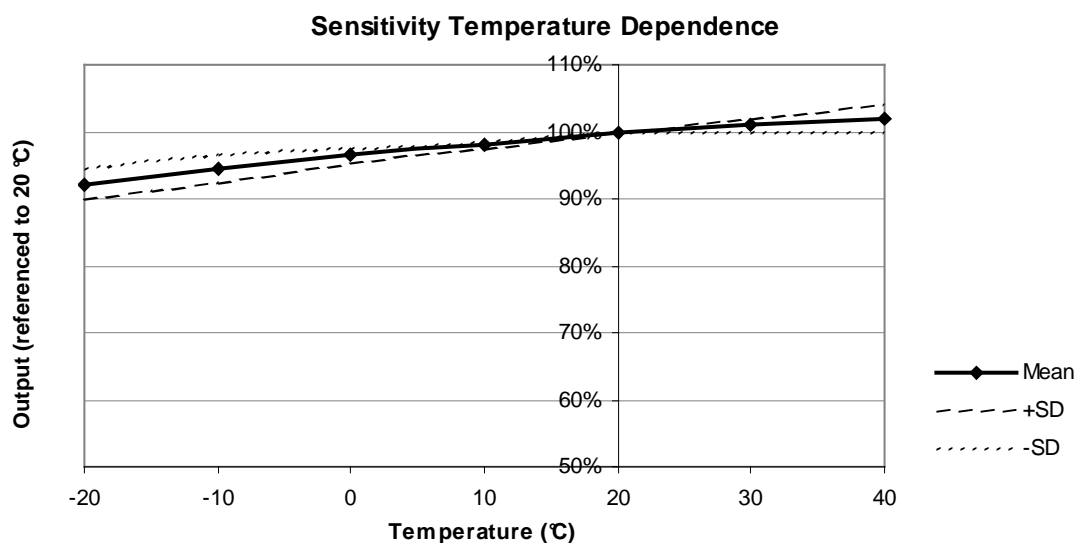

The baseline is virtually not affected by changes in temperature.

The data contained in this document is for guidance only. Membrapor AG accepts no liability for any consequential losses, injury or damage resulting from the use of this document or the information contained within it. The data is given for guidance only. Customers should test under their own conditions, to ensure that the sensors are suitable for their own requirements.