

DETAILS

Product Number	CS14632_STRADA-2X2MX-DWC
Family	STRADA
Type	Assembly
Color	clear
Diameter	90x90 mm
Height	11,13 mm
Style	square
Optic Material	PMMA
Holder Material	
Fastening	screw
Status	production ready
ROHS Compliant	Yes
Date Updated	1/04/2016



OPTICAL PROPERTIES

LED	Viewing Angle	Light Beam	Efficiency	cd/lm	Connector
LUXEON M	asymmetric deg	Streetligh...	94 %	0.610	-
XHP70	asymmetric deg	Streetligh...	94 %	0.530	-
XHP50	asymmetric deg	Streetligh...	94 %	0.610	-
LUXEON MZ	Asymmetric deg	Streetligh...	94 %	0.800	-
XM-L	asymmetric deg	Streetligh...	94 %	0.730	-
Duris S10	sim: Asymmetric	Streetligh...	92 %	0.530	-
LUXEON XR-M square 2x2	asymmetric deg	Streetligh...	94 %	0.610	-
NV4x144A	Asym deg	Streetligh...	94 %	0.600	-
Duris P10	sim: Asym	Streetligh...	sim: 92 %	sim: 0.000	-

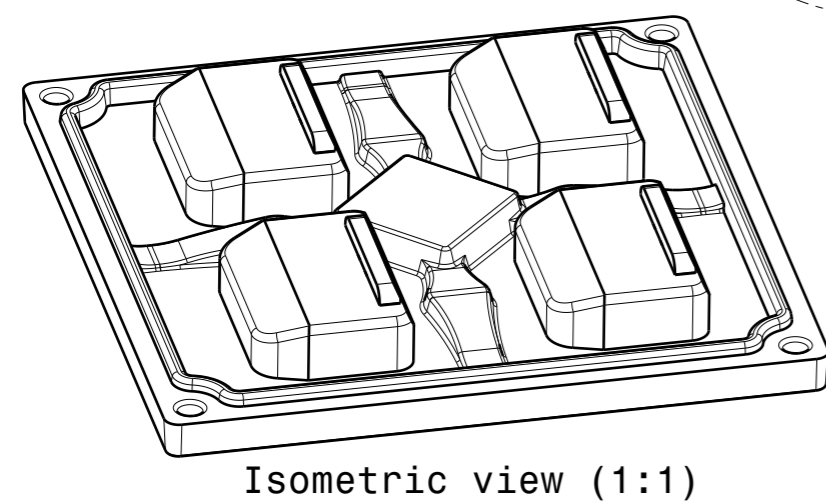
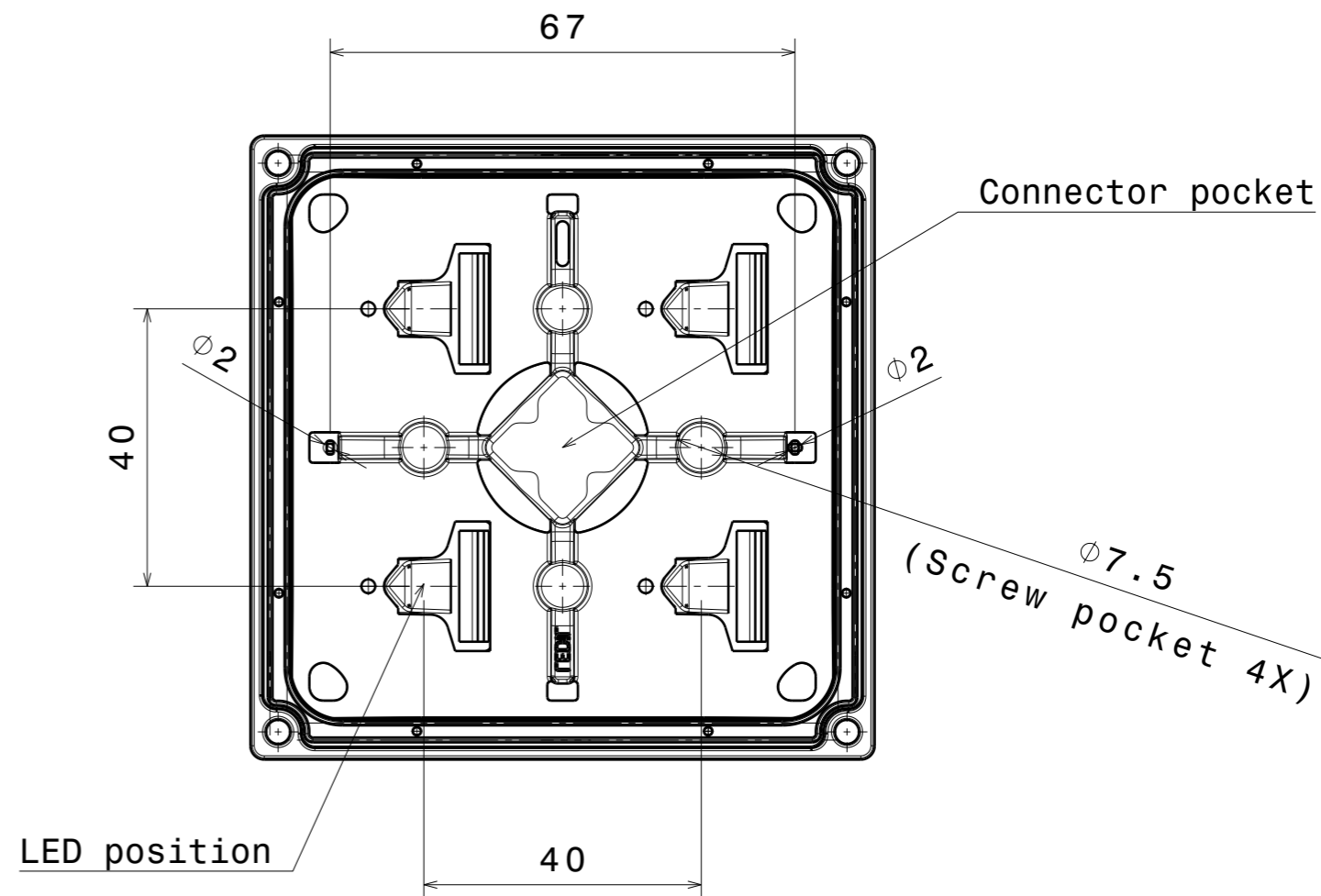
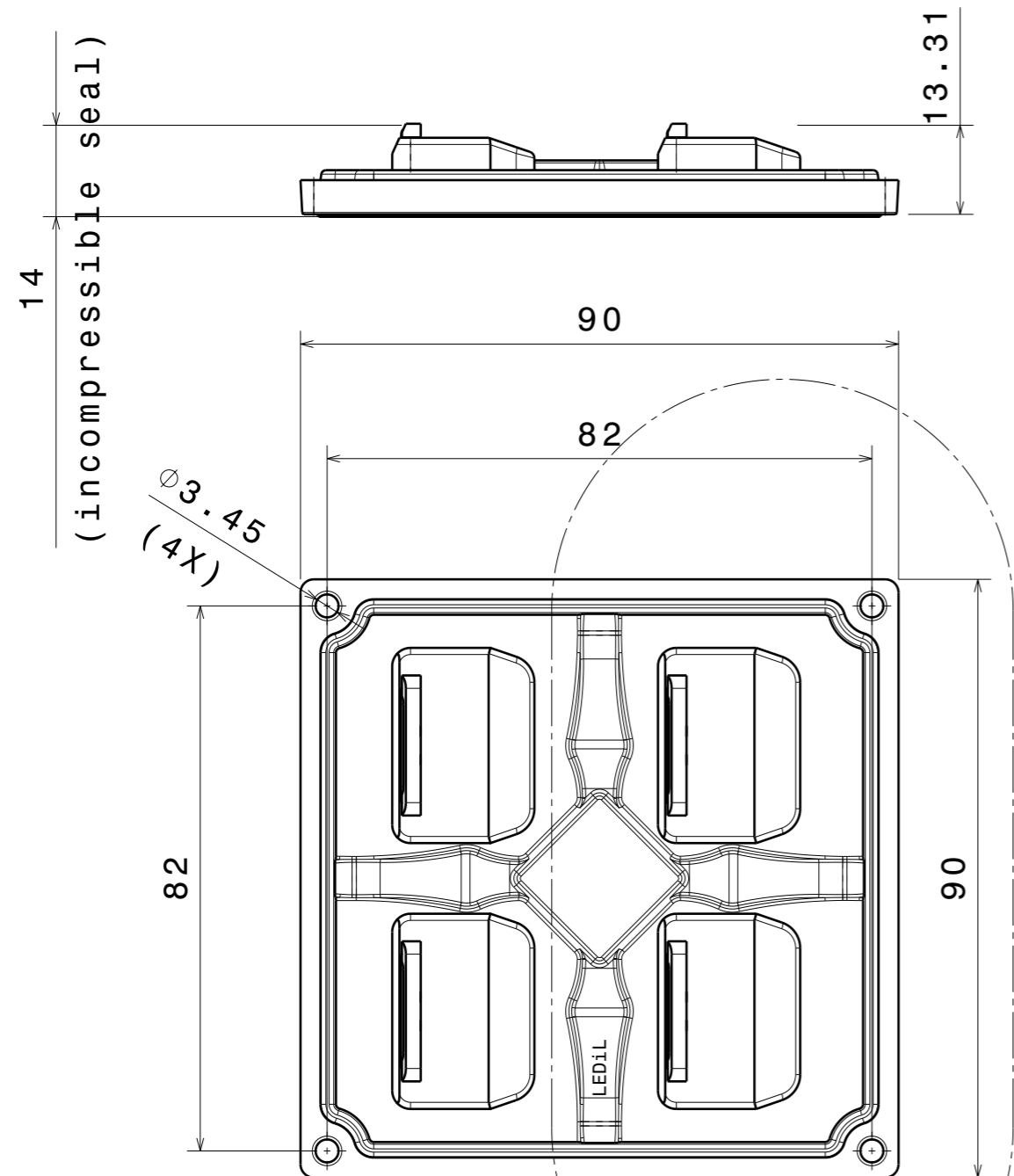

Beam direction

Isometric view (1:1)

INDEX	PART NO	DESCRIPTION	MATERIAL	COLOUR
1	C14631	STRADA-2X2MX-SEAL	silicone	
2	C14630	STRADA-2x2MX-DWC	PMMA	

Tolerances if not otherwise shown
According to DIN ISO 2768-1
Linear measures:
up to 30mm class M, otherwise class C
According to DIN ISO 2768-2
Form and position: class L

LEDiL LediL Oy
Salorankatu 10
FIN 24240 SALO
Finland

THIRD ANGLE PROJECTION:

DRAWING TITLE
CS14632_STRADA-2X2MX-DWC

This drawing is the property of LEDiL Oy. It may not be reproduced, copied or communicated without a written agreement with LEDiL Oy.

SIZE	PART NUMBER
A3	CS14632

SCALE	1:1	WEIGHT	41,3 g	SHEET	1/1
-------	-----	--------	--------	-------	-----

Luminaire: LEDiL Oy CS14632_STRADA-2X2MX-DWC_(Luxeon_M)

Lamps: 1 x Luxeon_M_(LXM8-SW30)_(2x2MX)_1410.8lm@250mA_P=11.0012W_I=0.2498A

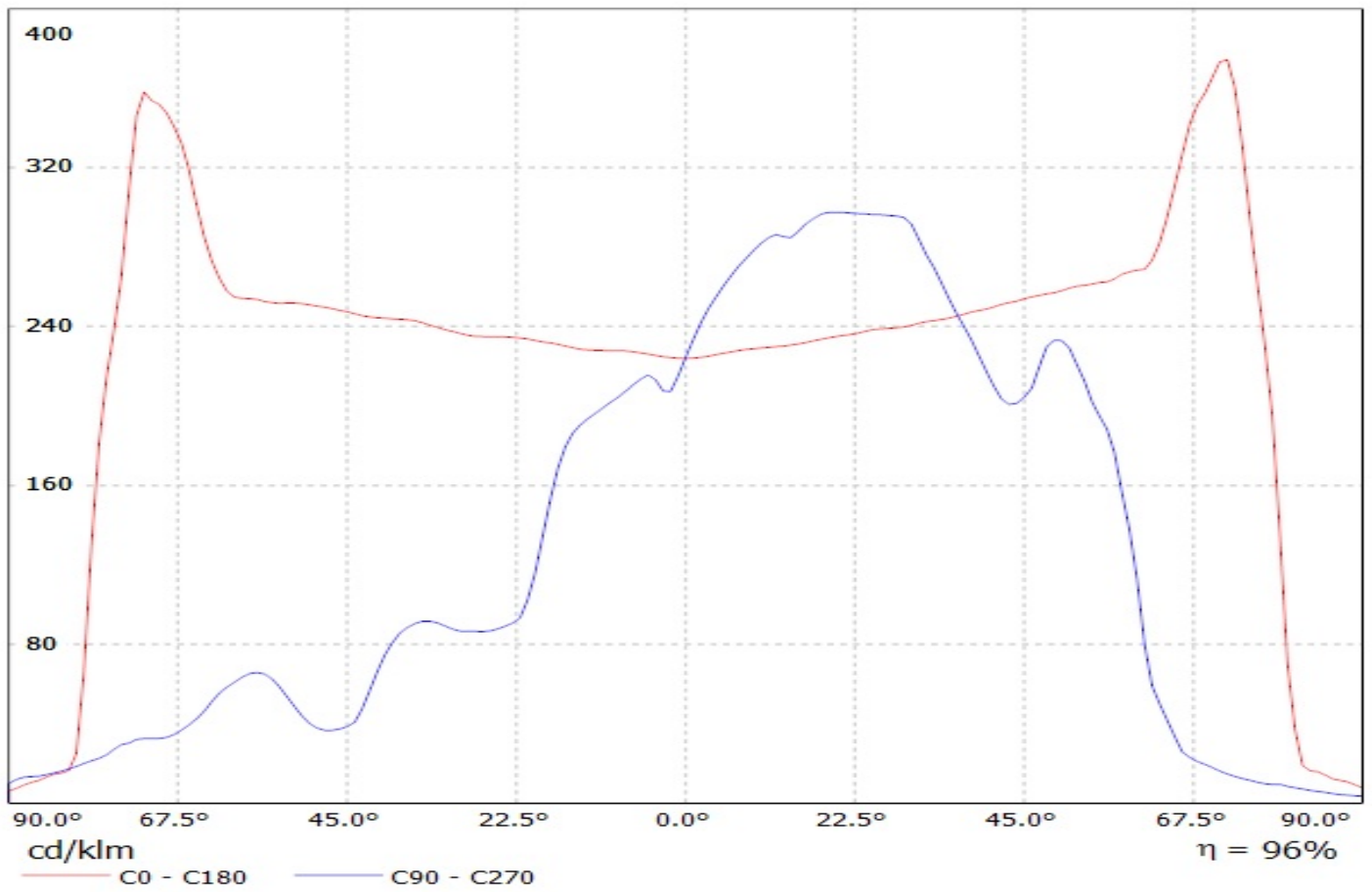

Luminaire: LEDiL Oy CS14632_STRADA-2X2MX-DWC_(XHP70)
Lamps: 1 x Cree_XHP70_(2x2MX)_1466.89lm@250mA_P=10.9332W_I=0.2498A

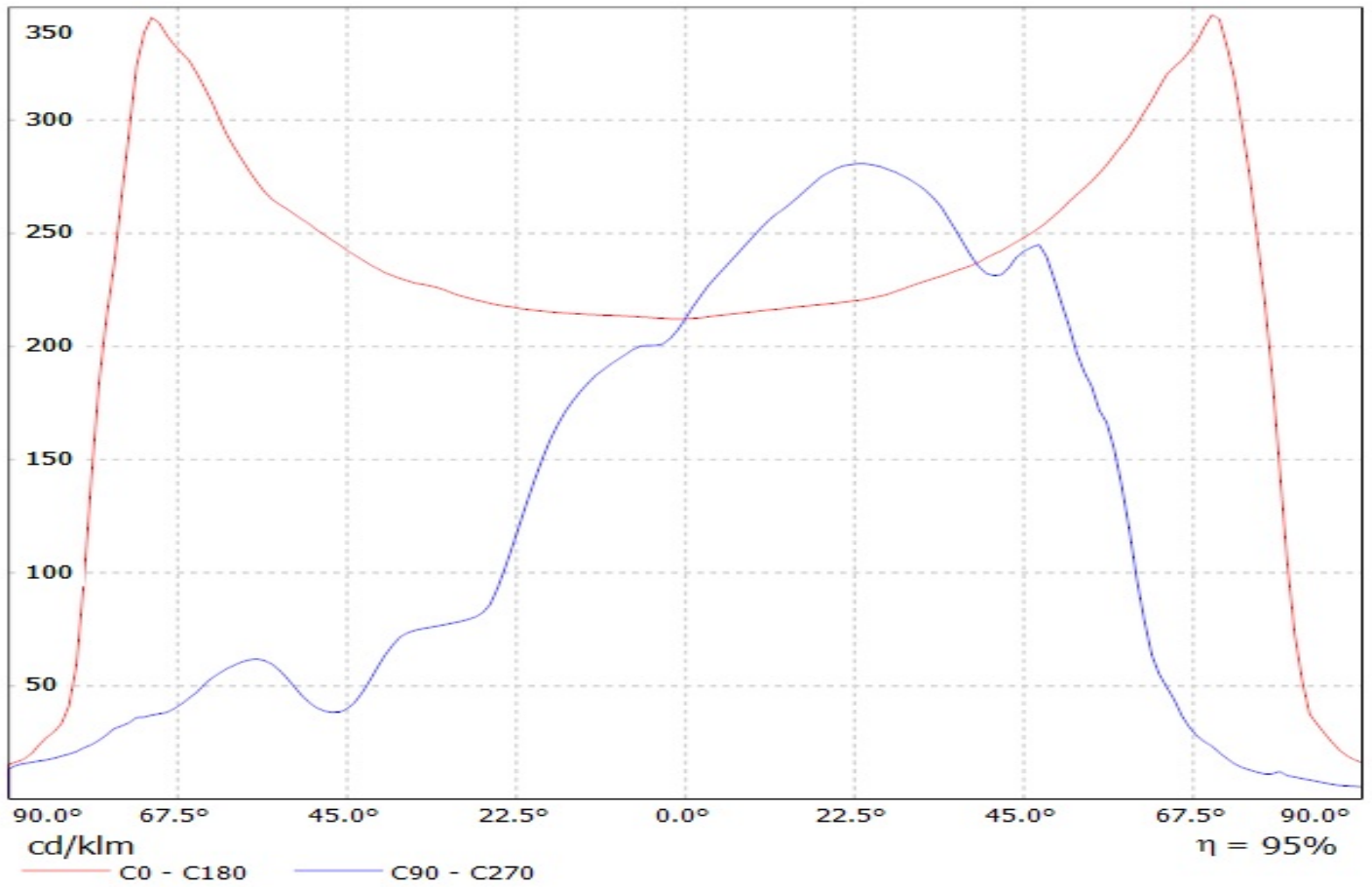

Luminaire: LEDiL Oy CS14632_STRADA-2X2MX-DWC_(XHP50)

Lamps: 1 x Cree_XHP50_(XHP50-0-1B0-J20-D0-B-01)_(2x2MX)_1832.8lm@250mA_P=11.3379W_I=0.2498A

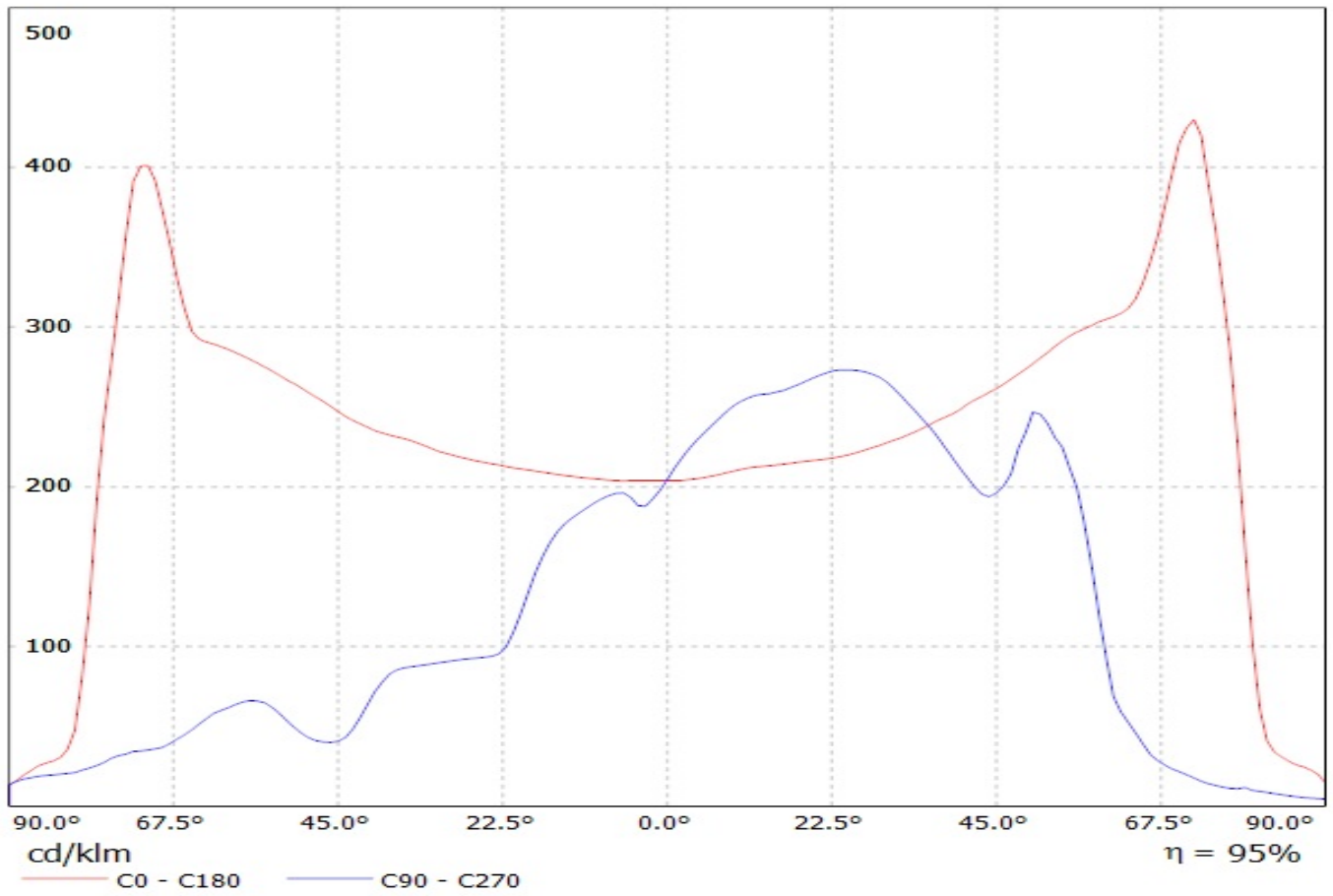

Ledil CS14632_Strada-2x2MX-DWC_(Luxeon_MZ) / LDC (Linear)

Luminaire: Ledil CS14632_Strada-2x2MX-DWC_(Luxeon_MZ)

Lamps: 1 x Luxeon_MZ-2x2MX_(LMZ9-SW30)_1123.93lm@250mA_CCT=3000K_P=10.967W_I=0.25A

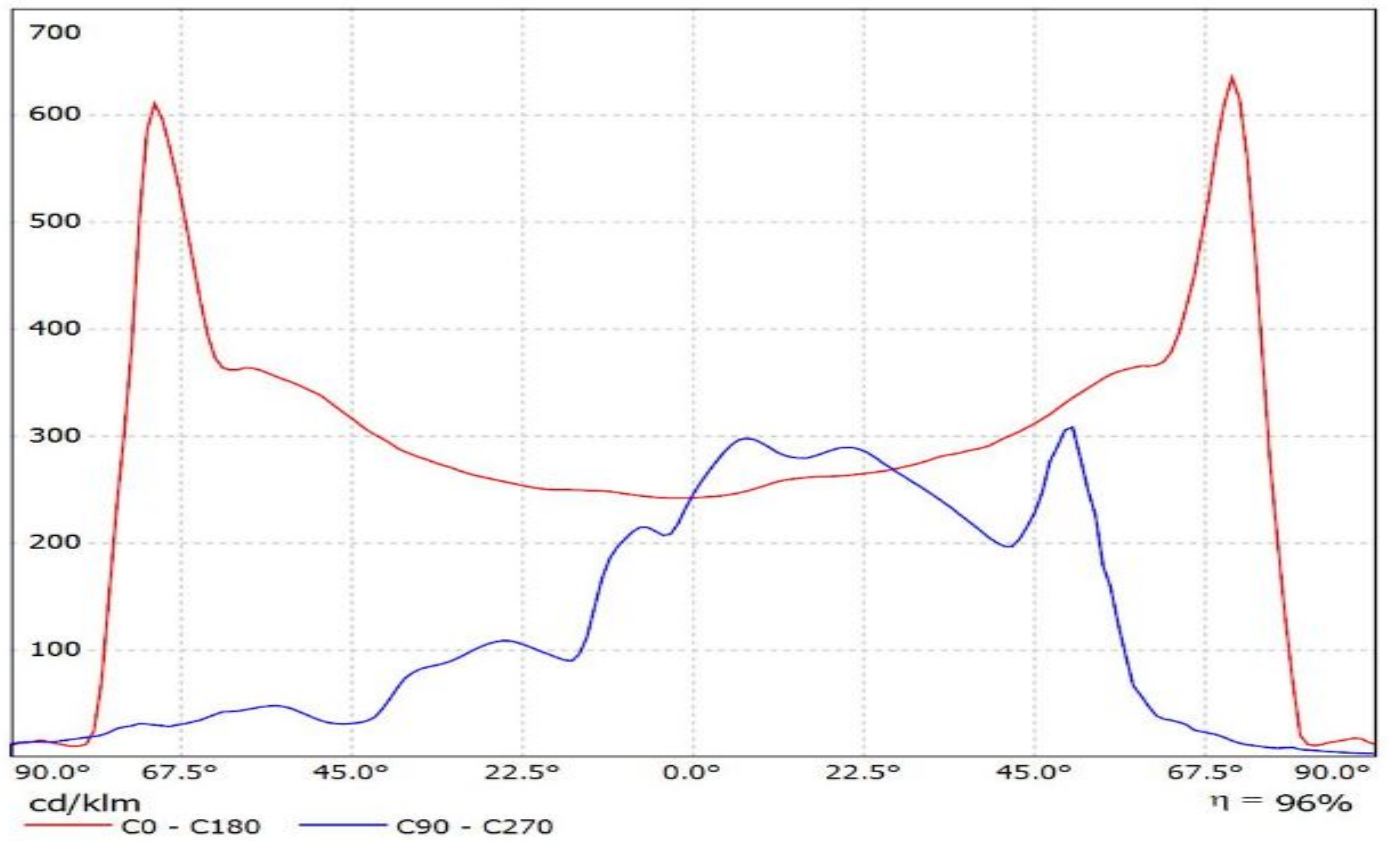

Luminaire: LEDiL Oy CS14632_STRADA-2X2MX-DWC_(XM-L-2x2MX)

Lamps: 1 x Cree_XM-L-2x2MX_(XMLAWT-0-5A3-T50-0L-0001)_376.168lm@250mA_P=2.76364W_I=0.250A

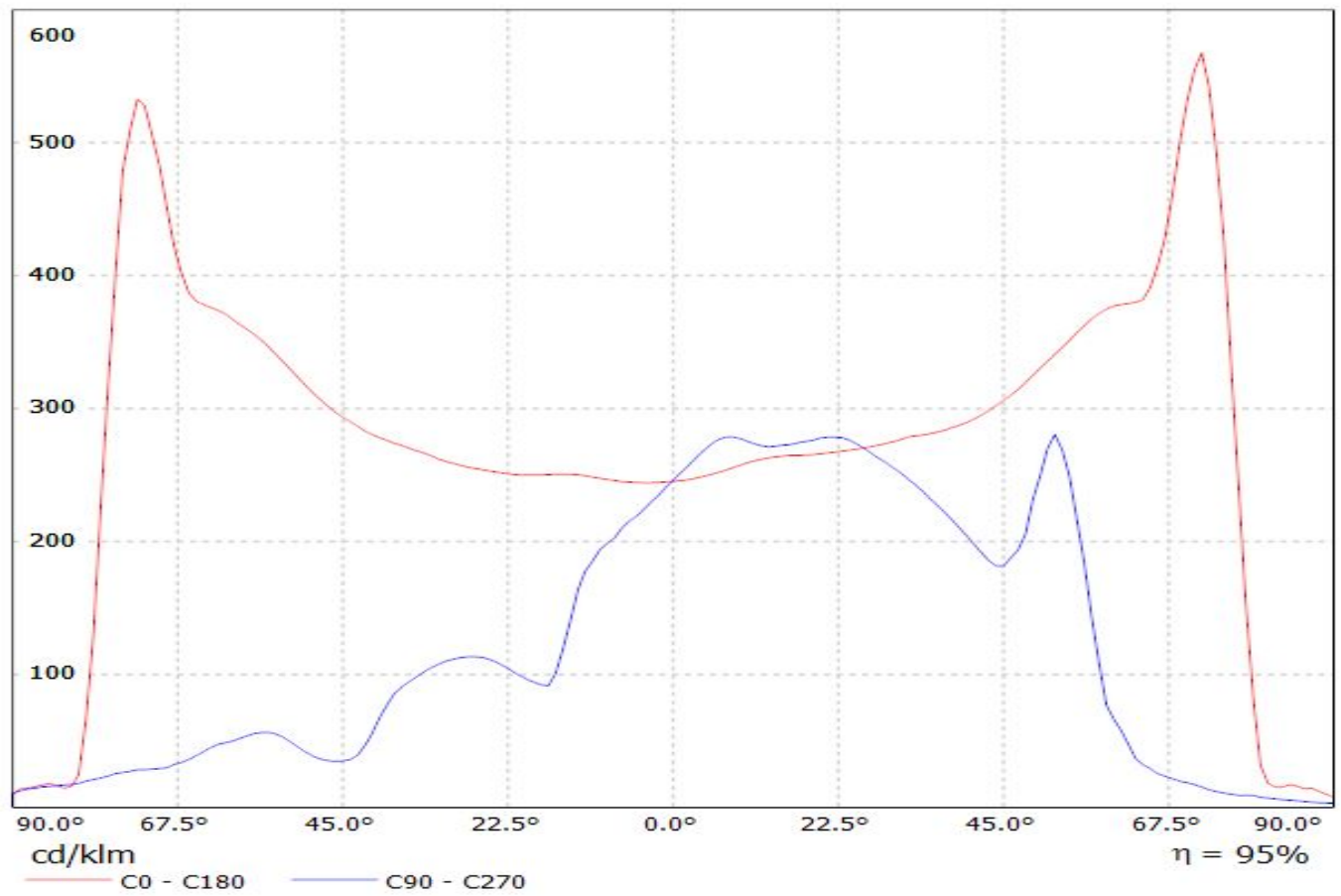

Luminaire: LEDiL Oy CS14632_STRADA-2X2MX-DWC_(L2M0-xxxx004MC2200)
Lamps: 1 x Luxeon_M_(L2M0-xxxx004MC2200)_1410.8lm@250mA_P=11.0012W_I=0.2498A

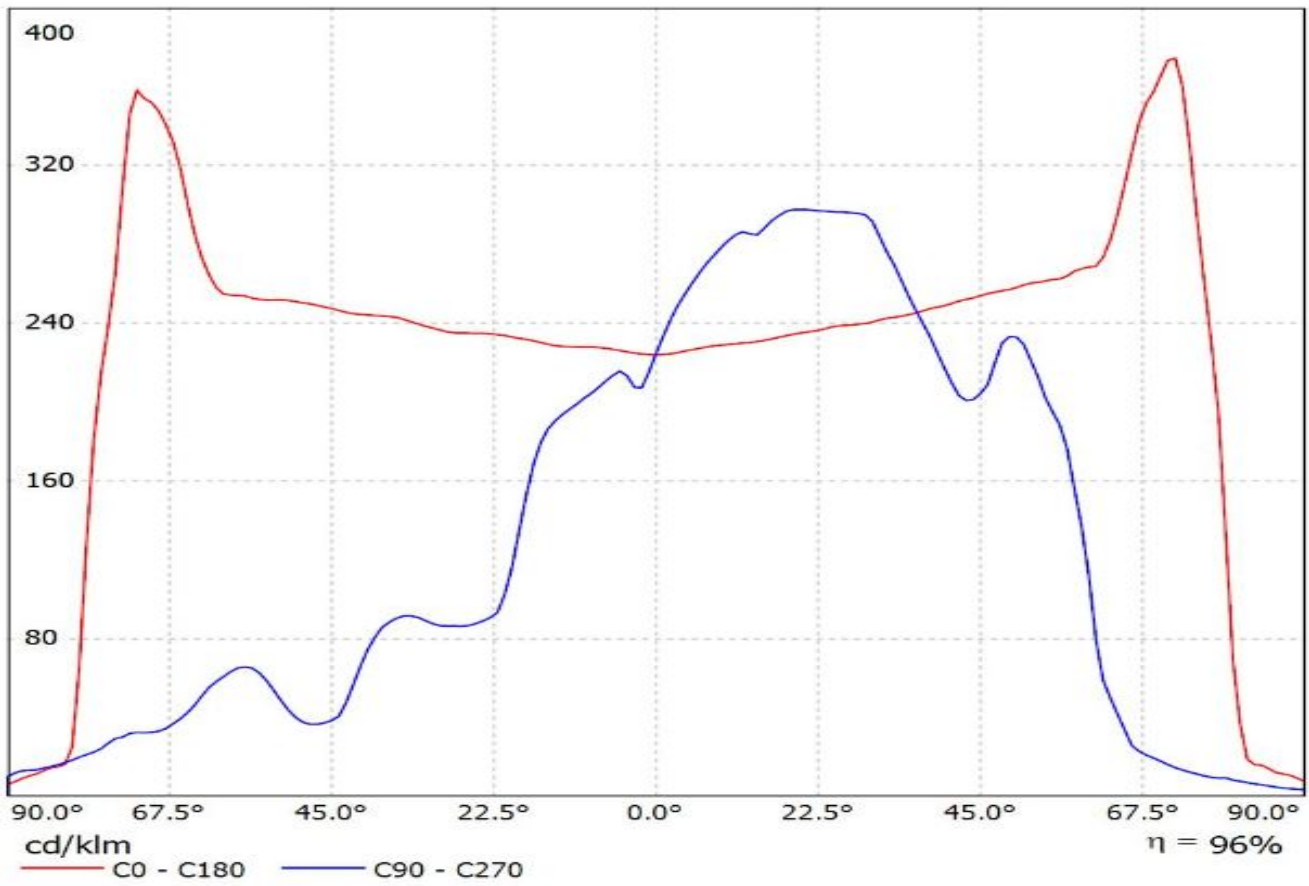

Luminaire: LEDiL Oy CS14632_STRADA-2X2MX-DWC_(NV4x144A)
Lamps: 1 x Nichia_NV4x144A_1841.22lm@250mA_P=10.9615W_I=0.250A

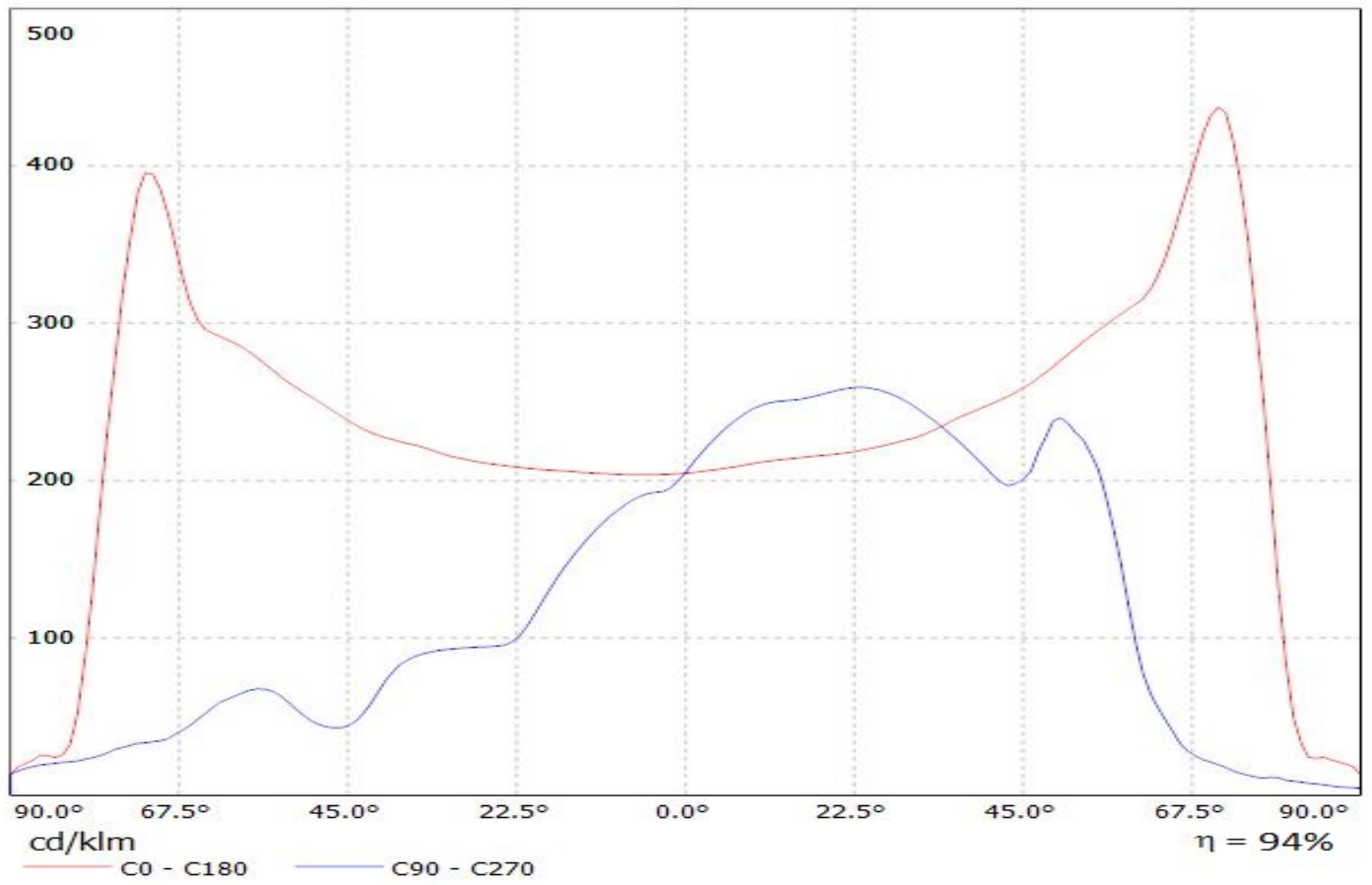

Luminaire: LEDiL Oy CS14632_STRADA-2X2MX-DWC_(Luxeon_M)

Lamps: 1 x Luxeon_M_(LXM8-SW30)_(2x2MX)_1410.8lm@250mA_P=11.0012W_I=0.2498A

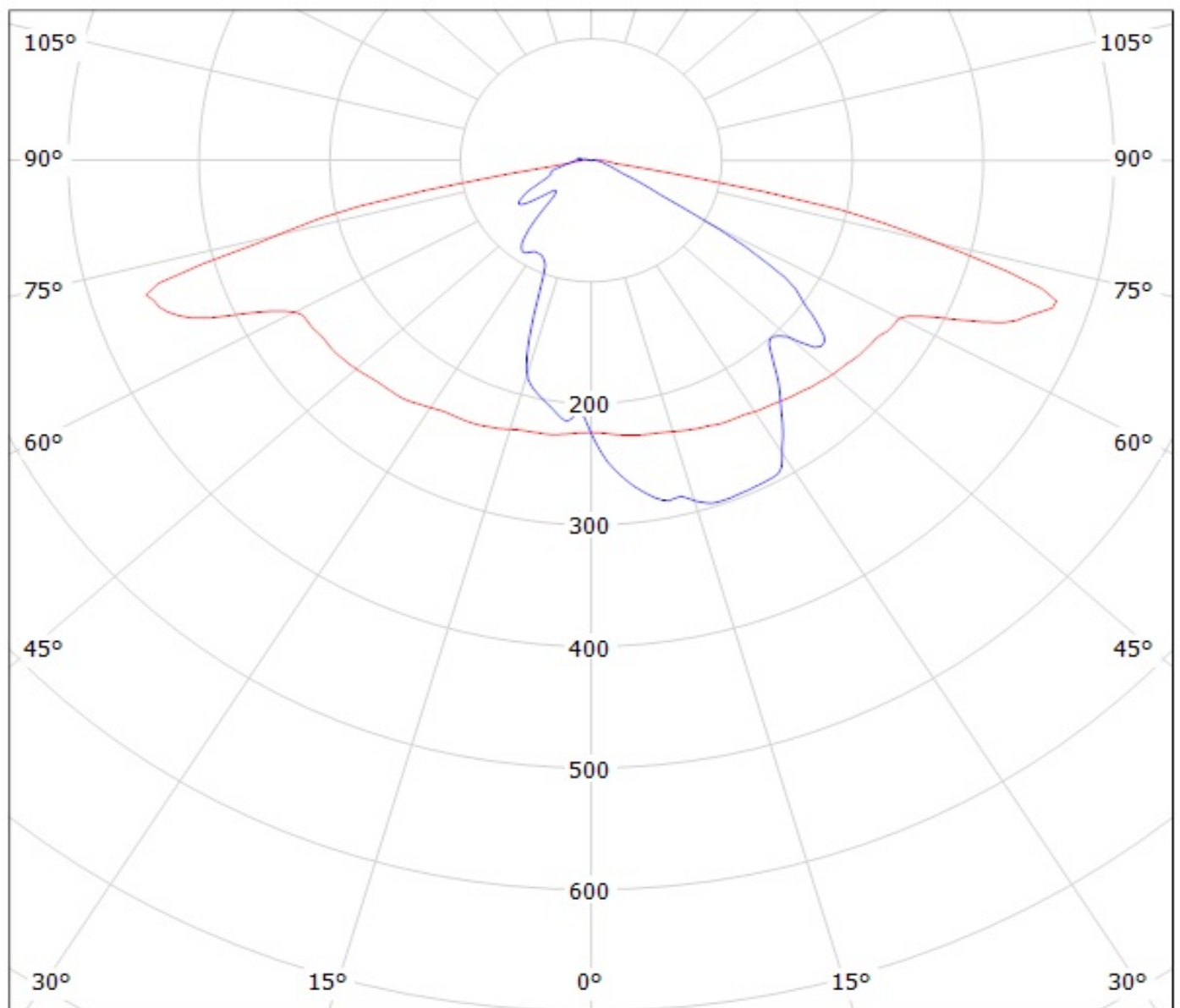

cd/klm

— C0 - C180

— C90 - C270

$\eta = 96\%$

Luminaire: LEDiL Oy CS14632_STRADA-2X2MX-DWC_(XHP70)
Lamps: 1 x Cree_XHP70_(2x2MX)_1466.89lm@250mA_P=10.9332W_I=0.2498A

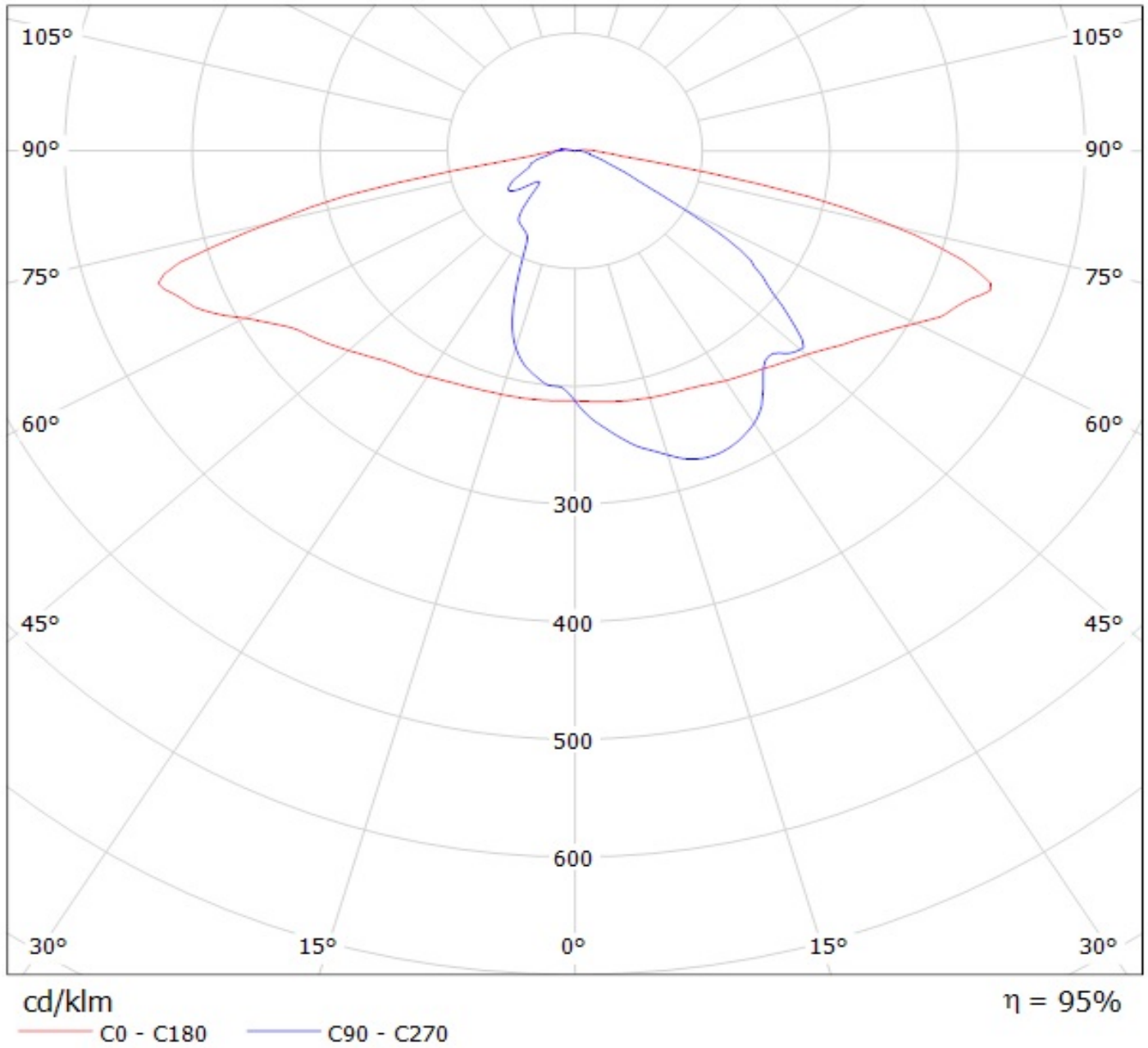

Luminaire: LEDiL Oy CS14632_STRADA-2X2MX-DWC_(XHP50)

Lamps: 1 x Cree_XHP50_(XHP50-0-1B0-J20-D0-B-01)_(2x2MX)_1832.8lm@250mA_P=11.3379W_I=0.2498A

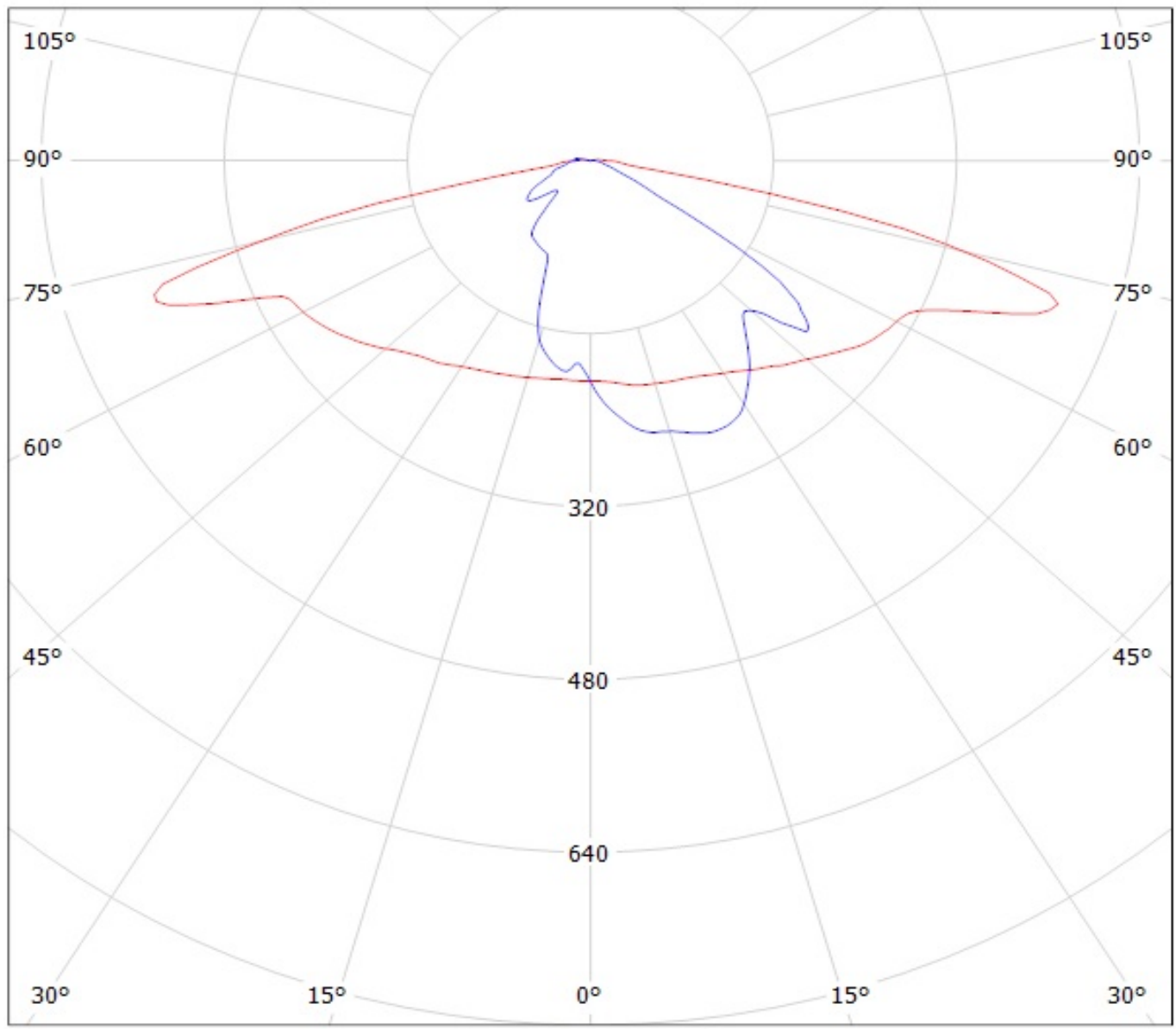

cd/klm

— C0 - C180 — C90 - C270

$\eta = 95\%$

Ledil CS14632_Strada-2x2MX-DWC_(Luxeon_MZ) / LDC (Polar)

Luminaire: Ledil CS14632_Strada-2x2MX-DWC_(Luxeon_MZ)

Lamps: 1 x Luxeon_MZ-2x2MX_(LMZ9-SW30)_1123.93lm@250mA_CCT=3000K_P=10.967W_I=0.25A

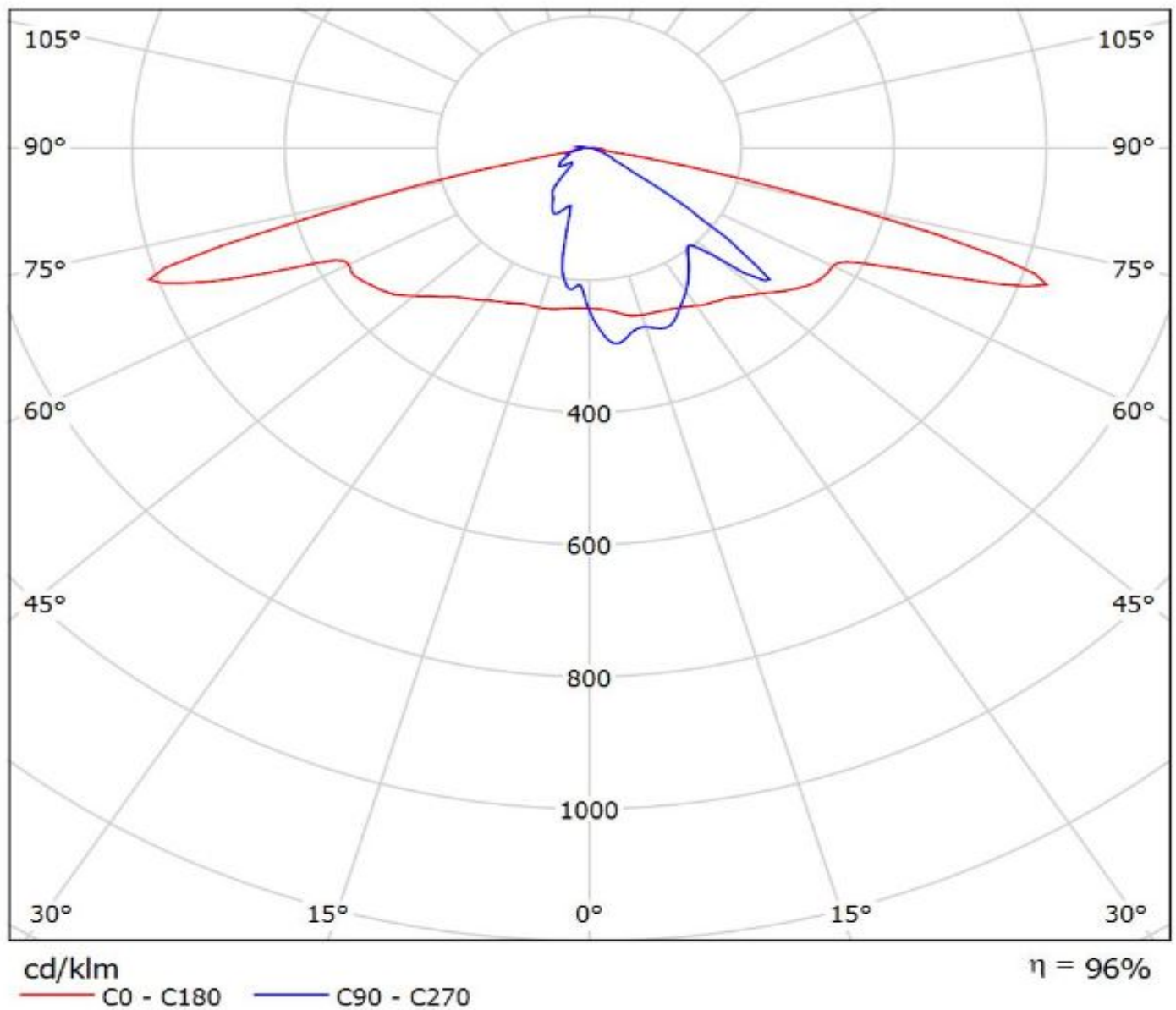

Luminaire: LEDiL Oy CS14632_STRADA-2X2MX-DWC_(XM-L-2x2MX)

Lamps: 1 x Cree_XM-L-2x2MX_(XMLAWT-0-5A3-T50-0L-0001)_376.168lm@250mA_P=2.76364W_η=0.250A

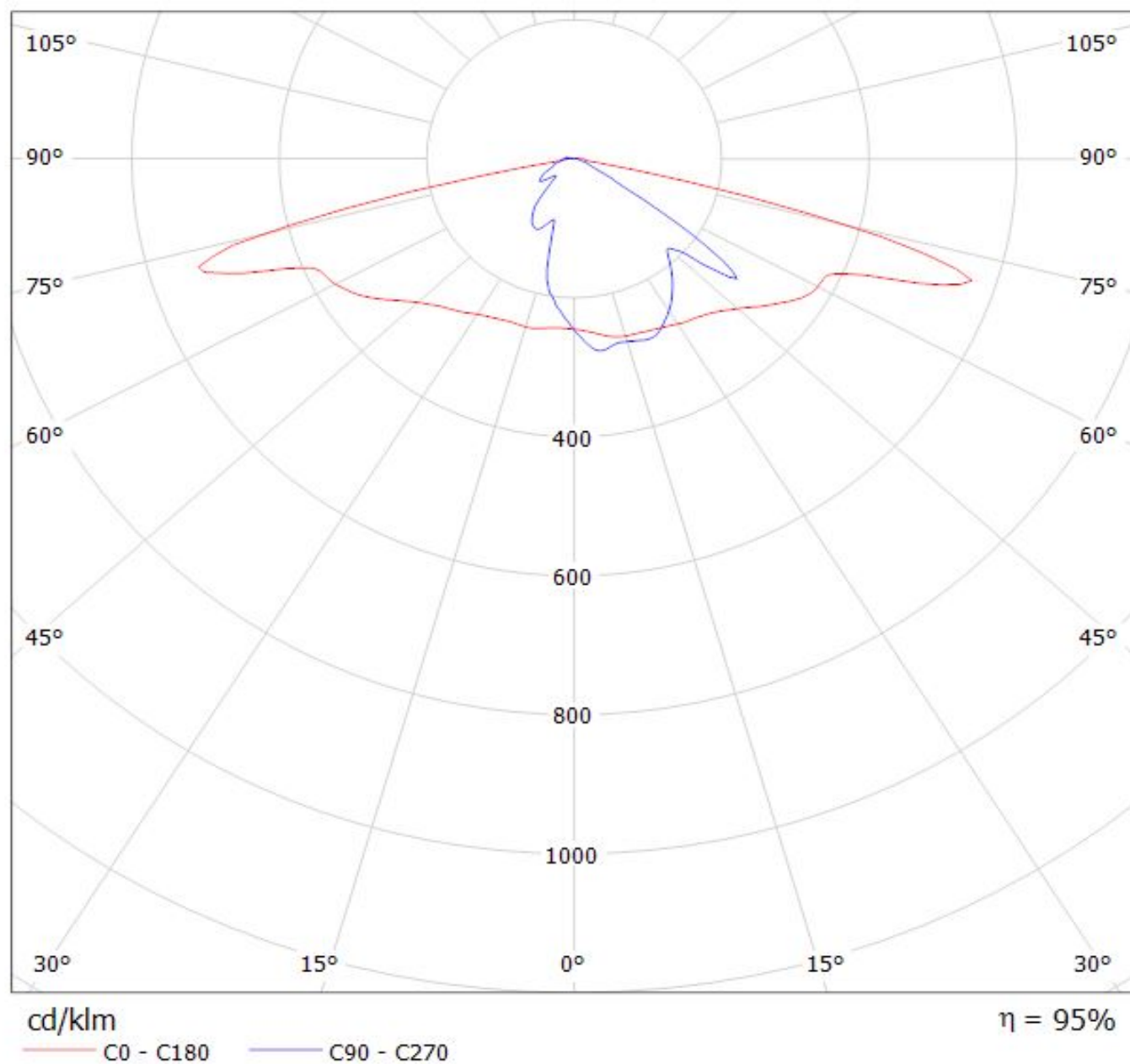

Luminaire: LEDiL Oy CS14632_STRADA-2X2MX-DWC_(L2M0-xxxx004MC2200)

Lamps: 1 x Luxeon_M_(L2M0-xxxx004MC2200)_1410.8lm@250mA_P=11.0012W_I=0.2498A

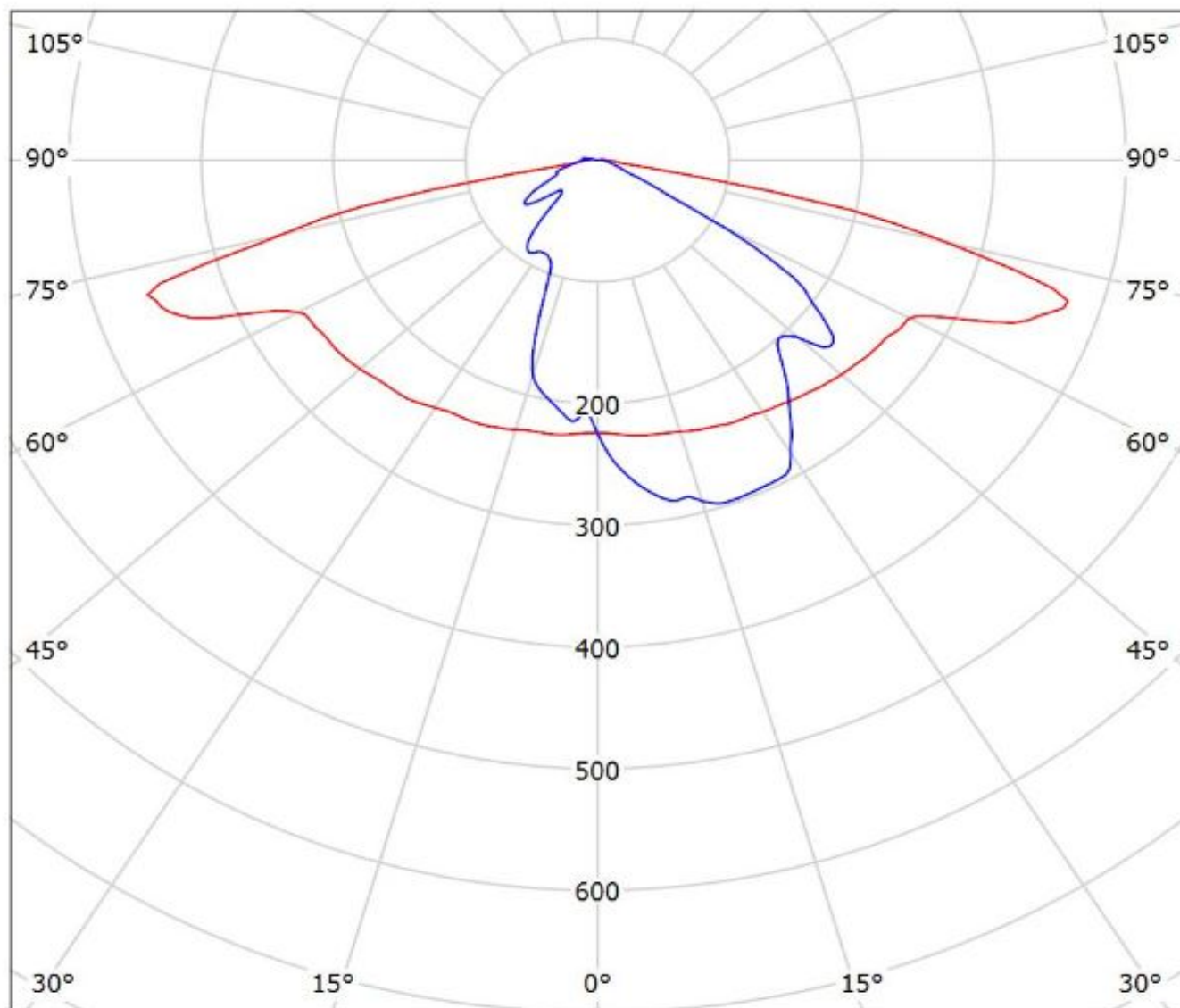

cd/klm

— C0 - C180

— C90 - C270

$\eta = 96\%$

Luminaire: LEDiL Oy CS14632_STRADA-2X2MX-DWC_(NV4x144A)
Lamps: 1 x Nichia_NV4x144A_1841.22lm@250mA_P=10.9615W_η=0.250A

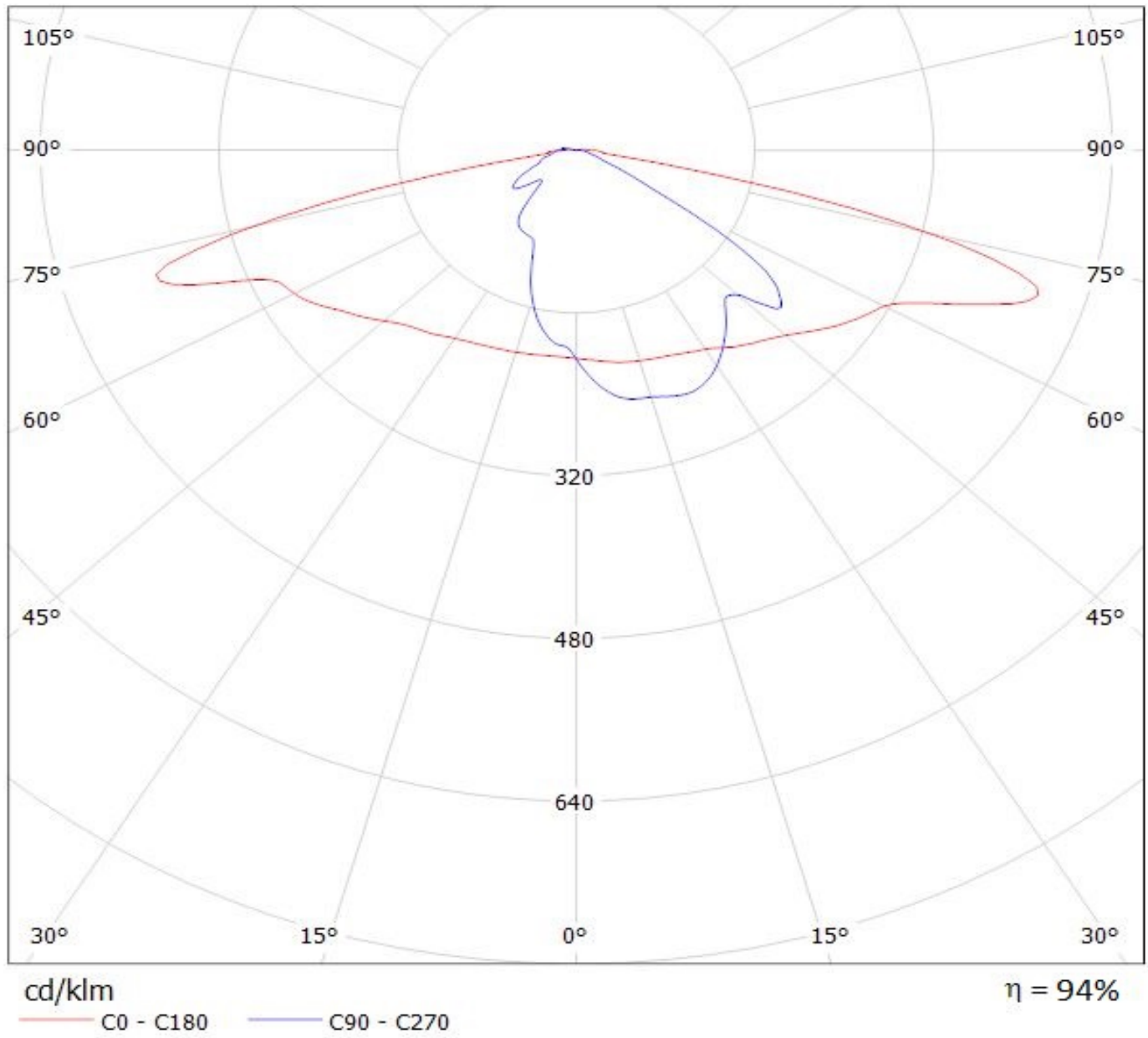

NOTE: The typical divergence will be changed by different color, chip size and chip position tolerance. The typical total divergence is the full angle measured where the luminous intensity is half of the peak value.