

DETAILS

Product Number	C15594_STRADA-2X2-MEW
Family	Strada-Module
Type	Lens
Color	clear
Diameter	50x50 mm
Height	10,16 mm
Style	square
Optic Material	PMMA
Holder Material	
Fastening	screw
Status	production ready
ROHS Compliant	Yes
Date Updated	7/02/2017



OPTICAL PROPERTIES

LED	Viewing Angle	Light Beam	Efficiency	cd/lm	Connector
XP-G2	Asymmetric deg	Asymmetric	94 %	1.100	-
XP-L HI	sim: Asymmetric	Asymmetric	-	-	-
XHP35 HI	sim: Asymmetric	Asymmetric	-	-	-
XT-E	sim: Asymmetric	Asymmetric	-	-	-
XP-L	sim: Asymmetric	Asymmetric	-	-	-
XHP35 HD	sim: Asymmetric	Asymmetric	-	-	-
XM-L2	sim: Asymmetric	Asymmetric	-	-	-
XP-G3	sim: Asymmetric	Asymmetric	-	-	-
LUXEON TX	sim: Asymmetric	Asymmetric	-	-	-
NVSxx19B/NVSxx19C	sim: Asymmetric	Asymmetric	-	-	-
NCSxx19B	sim: Asymmetric	Asymmetric	-	-	-
Oslon Square PC	sim: Asymmetric	Asymmetric	-	-	-
Oslon Square Gen3	Asymmetric deg	Asymmetric	87 %	0.950	-
Duris S8	sim: Asymmetric	Asymmetric	-	-	-
Duris P8	sim: Asym	Asymmetric	sim: 94 %	sim: 1.000	-

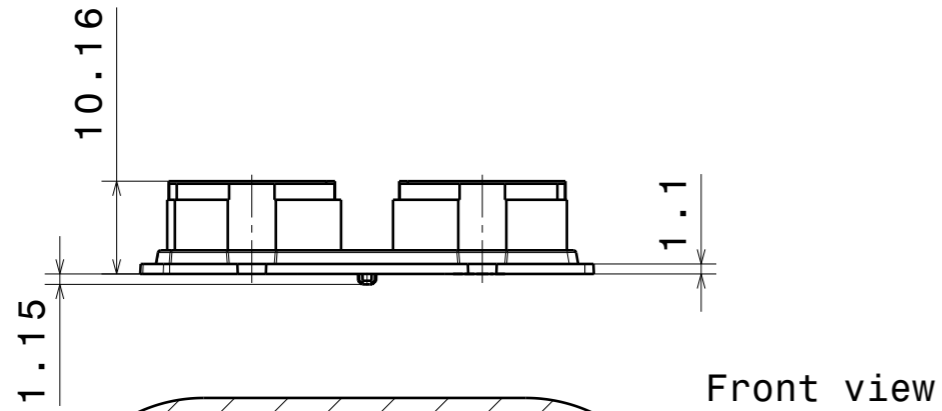
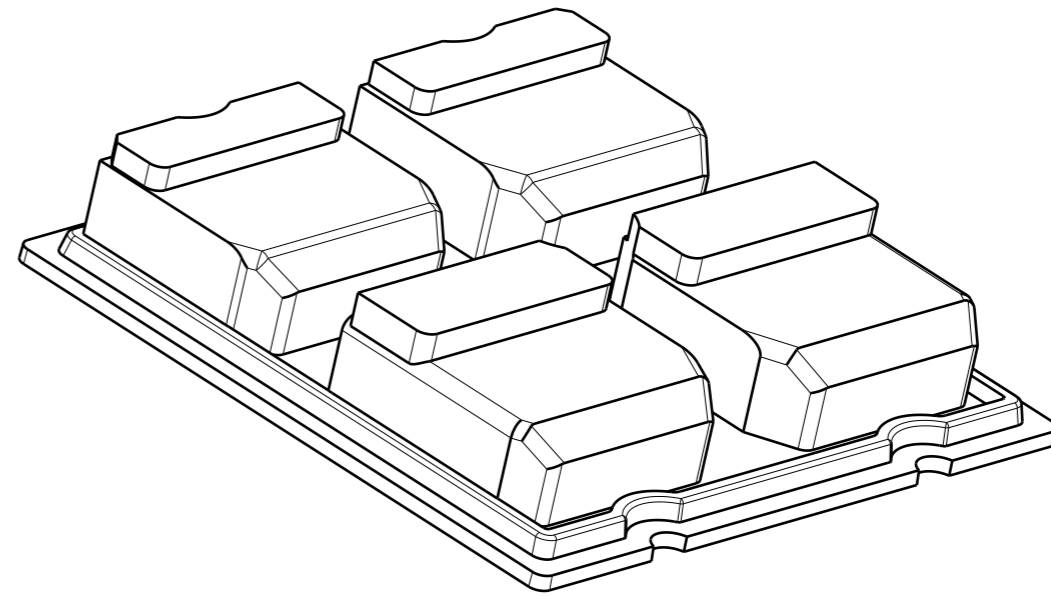
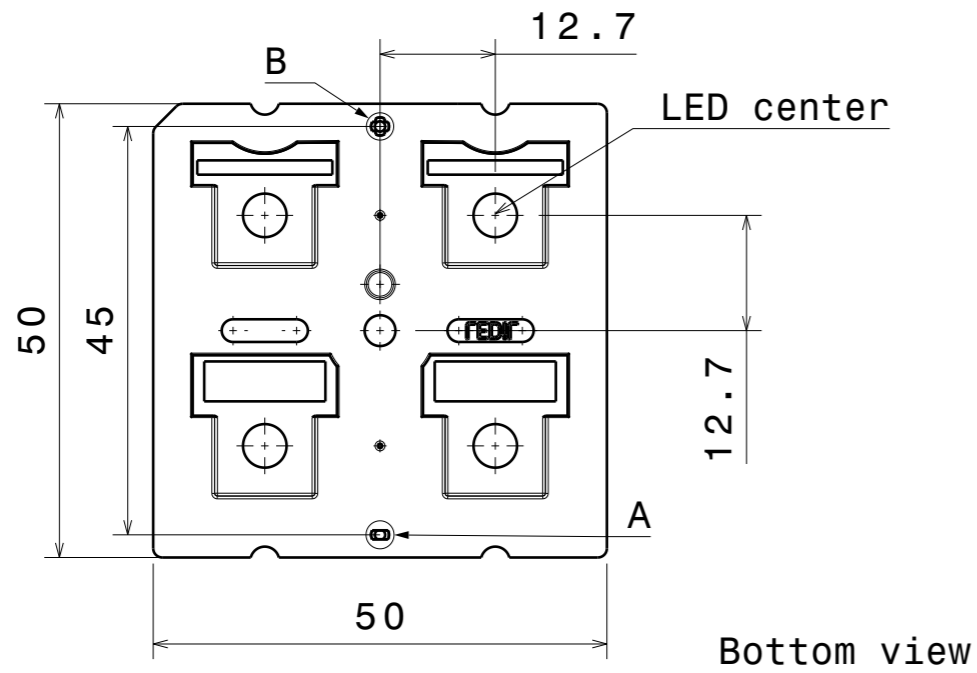

Isometric view

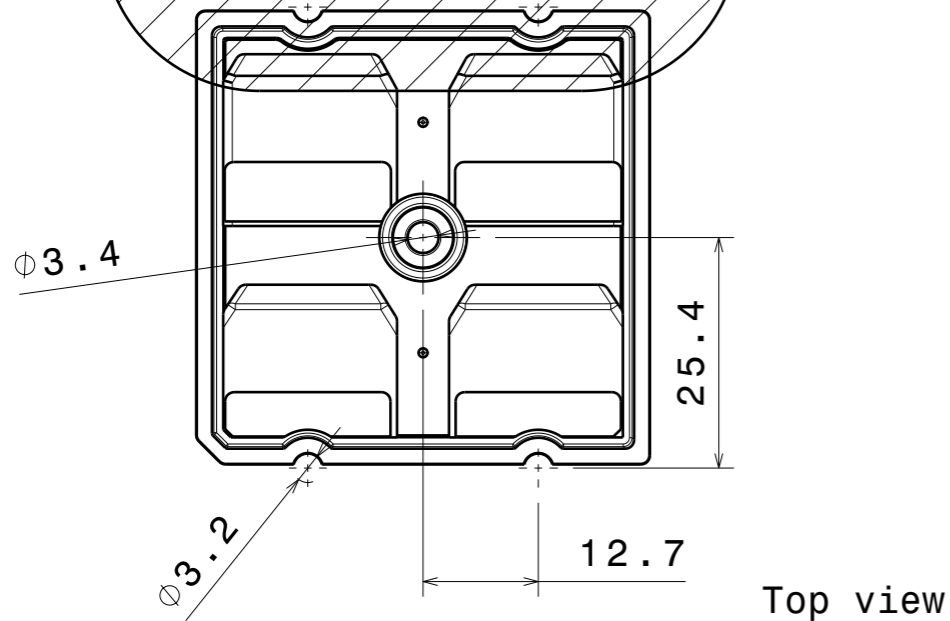
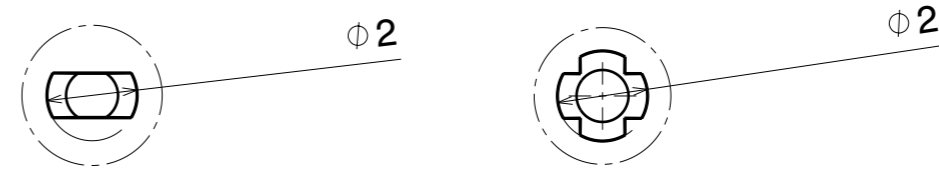
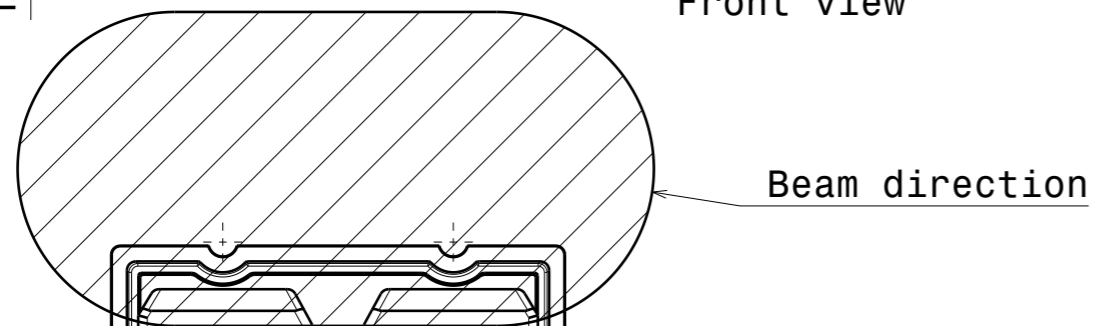

Detail A

Detail B

Tolerances if not otherwise shown
 According to DIN ISO 2768-1
 Linear measures:
 Up to 30mm class M, otherwise class C.
 According to DIN ISO 2768-2
 Form and position: class L

LEDiL LediL Oy
 Salorankatu 10
 FIN 24240 SALO
 Finland

THIRD ANGLE PROJECTION:

DRAWING TITLE
C15594_STRADA-2X2-MEW

This drawing is the property of LEDiL Oy. It may not be reproduced, copied or communicated without a written agreement with LEDiL Oy.

SIZE	PART NUMBER
A3	C15594

SHEET 1/1

Luminaire: LEDiL Oy C15594_STRADA-2X2-MEW_(XP-G2)

Lamps: 1 x Cree_XP-G2_(XPGBWT-L1-000-00G51)_408.625lm@250mA_P=2.95488W_I=0.25A

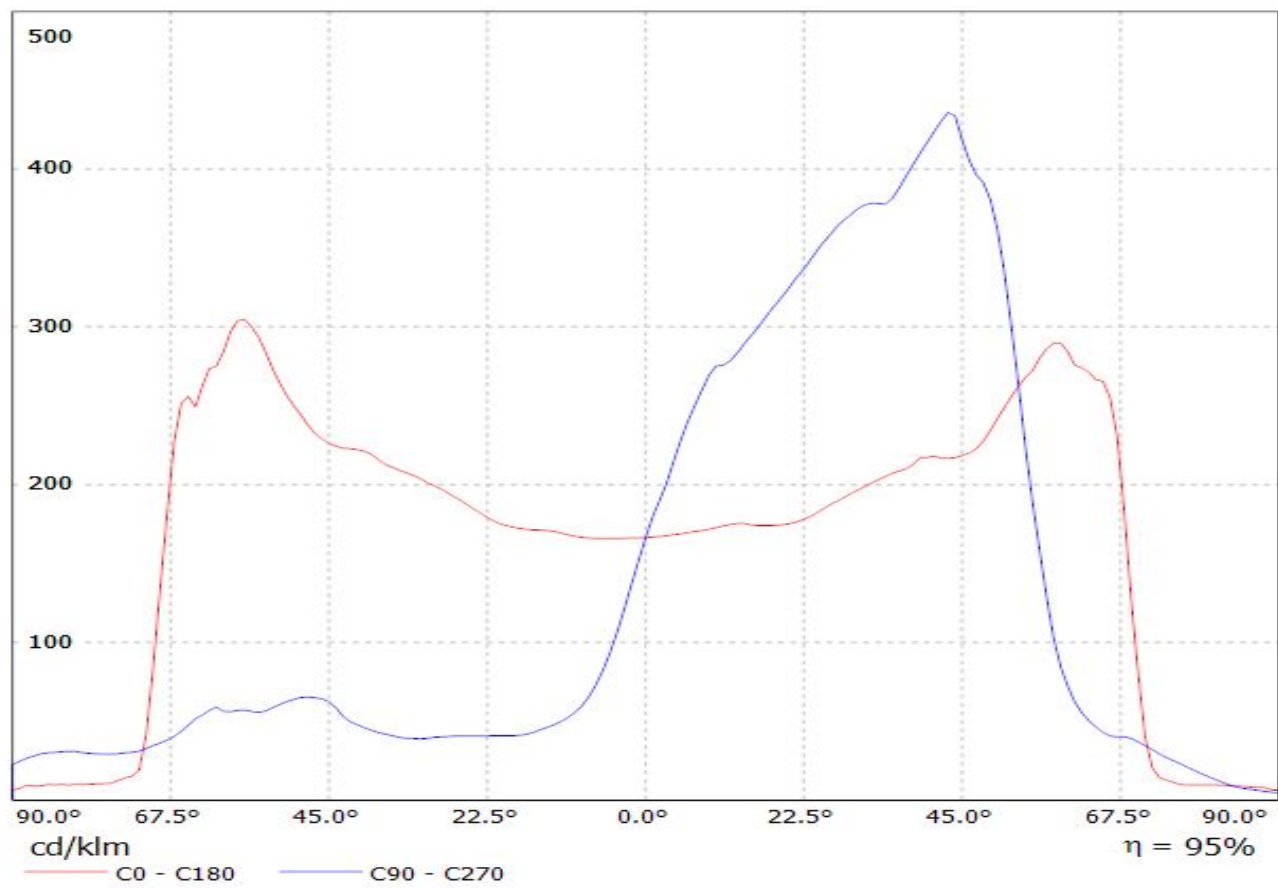

Luminaire: Ledil C15594_STRADA-2X2-MEW_(SQ_Gen3)_with_glass
Lamps: 1 x Osram_square_gen3_(GW_CSSRM2.PM)

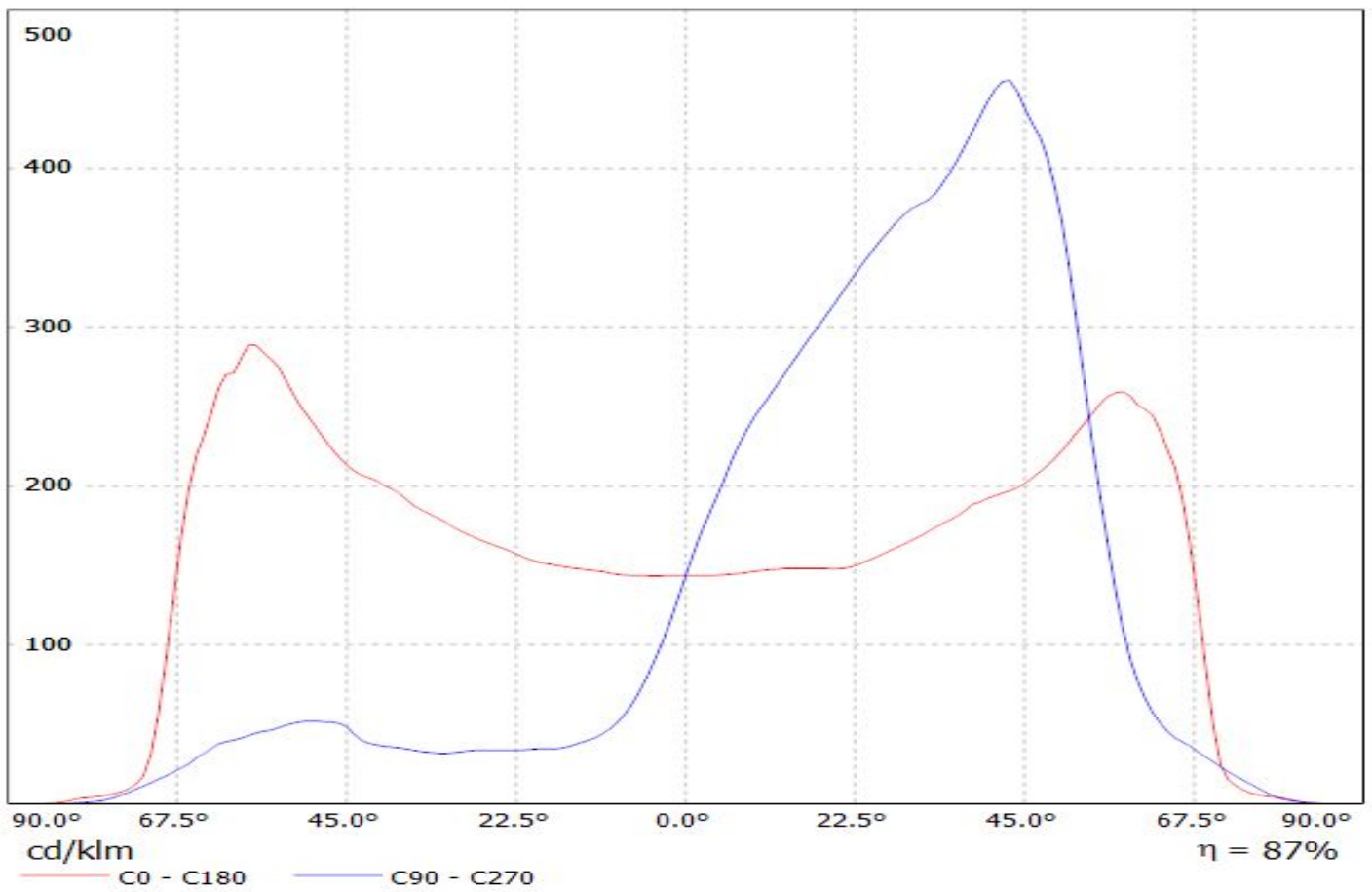

Luminaire: Ledil Oy C15594_STRADA-2X2-MEW_(Duris_P8)_SIMULATED
Lamps: 1 x Osram Duris P8 - GW PUSRA1.PM

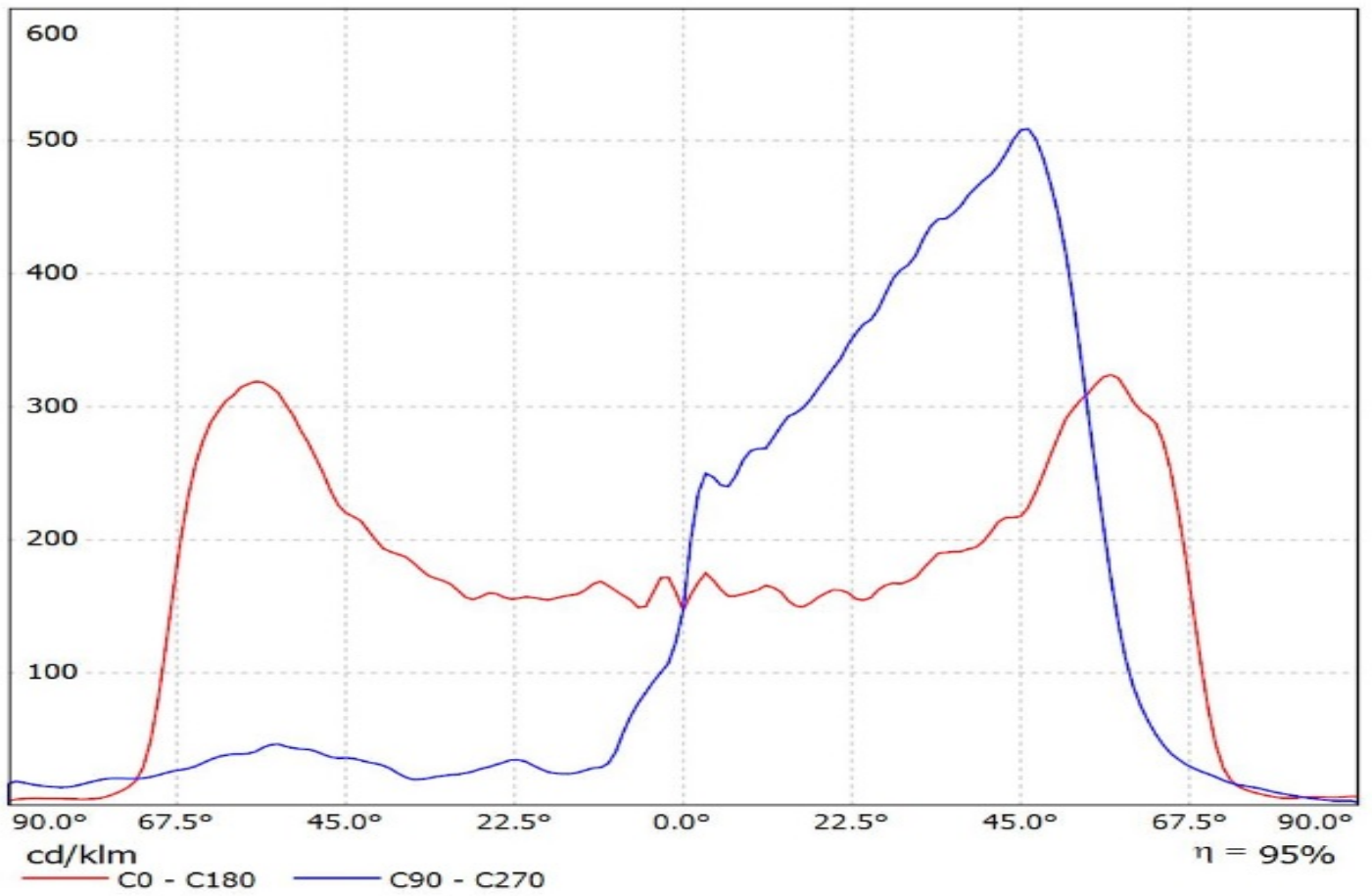

Luminaire: LEDiL Oy C15594_STRADA-2X2-MEW_(XP-G2)

Lamps: 1 x Cree_XP-G2_(XPGBWT-L1-000-00G51)_408.625lm@250mA_P=2.95488W_I=0.25A

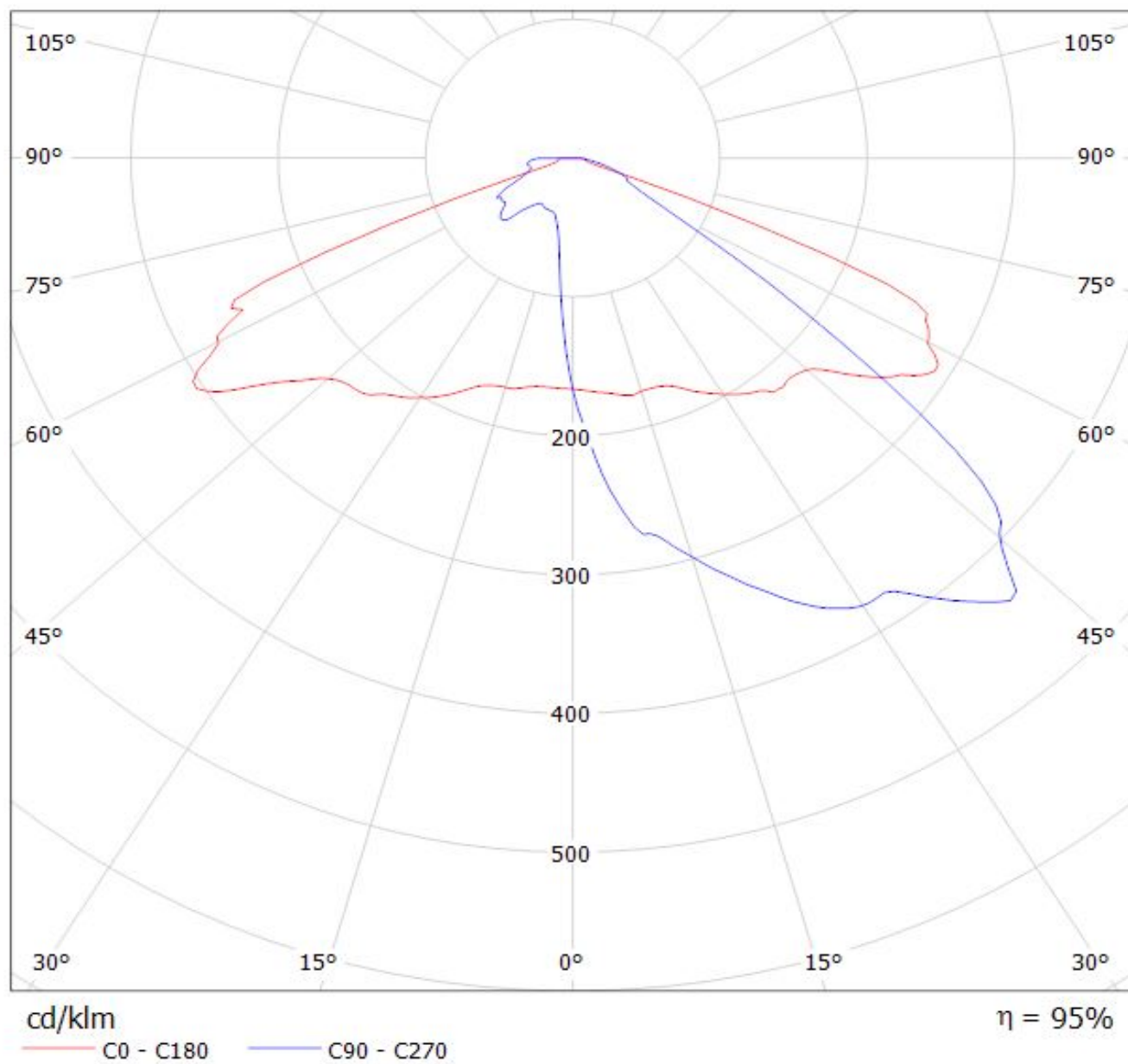

Luminaire: Ledil C15594_STRADA-2X2-MEW_(SQ_Gen3)_with_glass
Lamps: 1 x Osram_square_gen3_(GW_CSSRM2.PM)

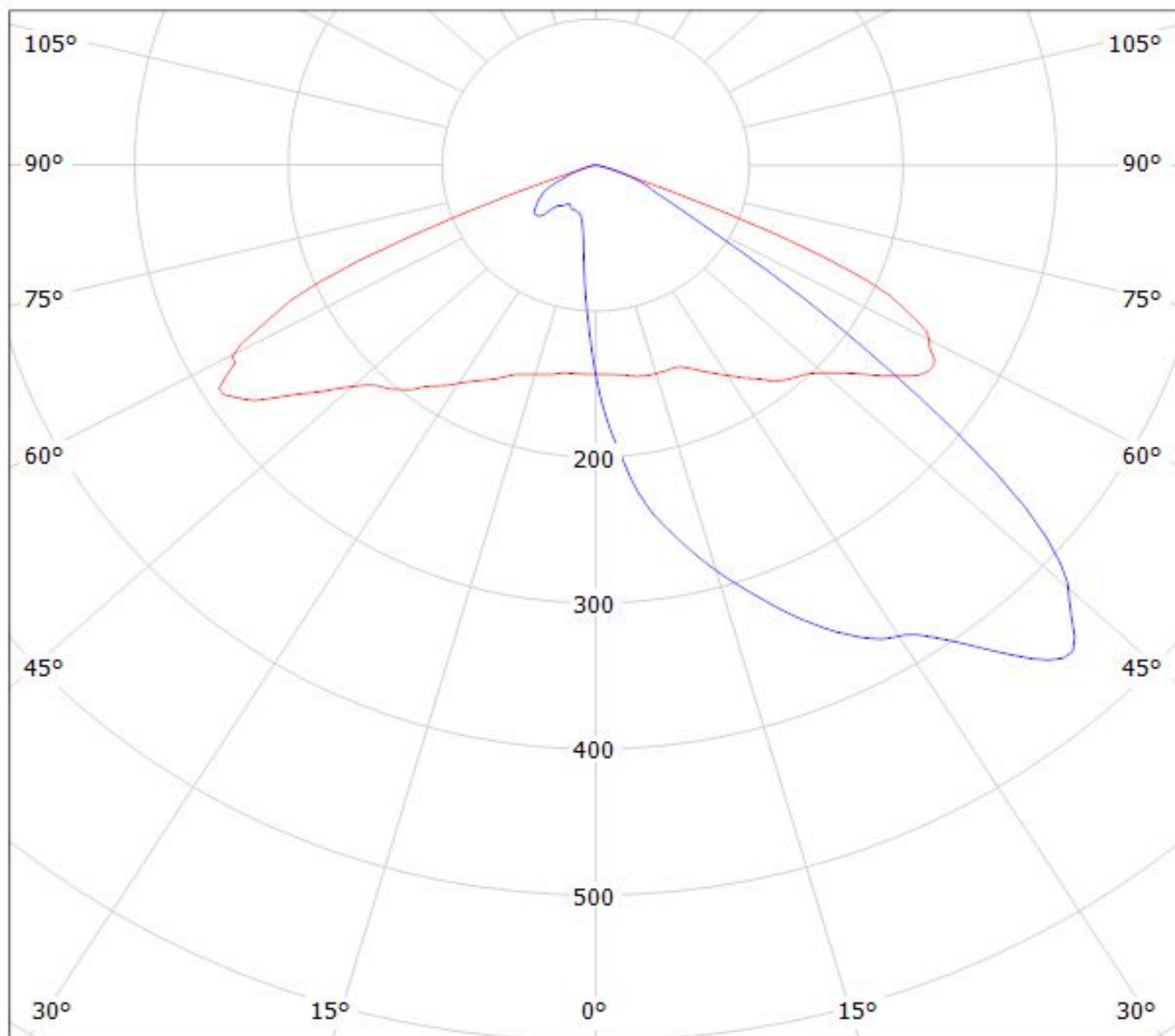

cd/klm

— C0 - C180 — C90 - C270

$\eta = 87\%$

Luminaire: Ledil Oy C15594_STRADA-2X2-MEW_(Duris_P8)_SIMULATED
Lamps: 1 x Osram Duris P8 - GW PUSRA1.PM

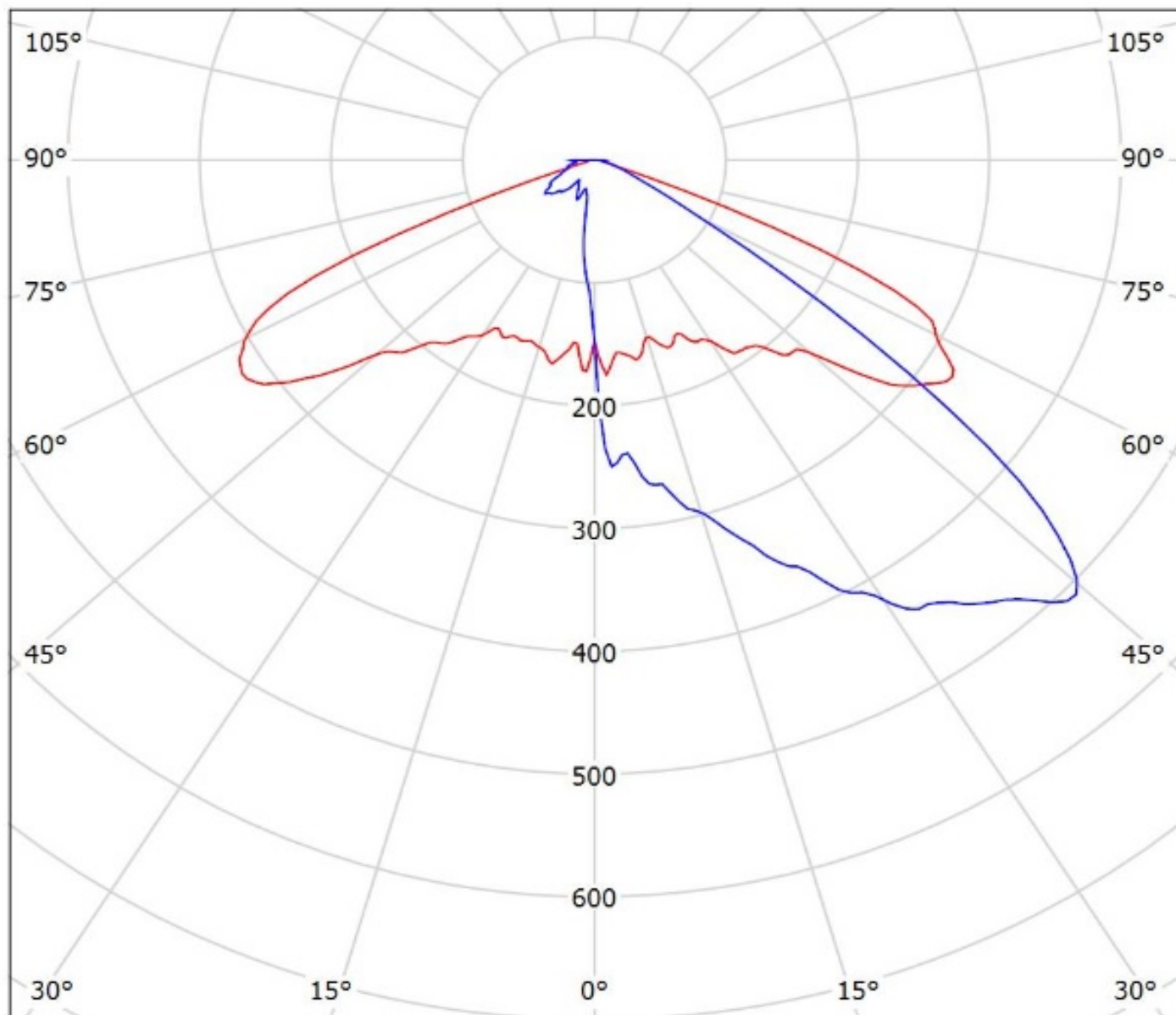

cd/klm

— C0 - C180 — C90 - C270

$\eta = 95\%$

NOTE: The typical divergence will be changed by different color, chip size and chip position tolerance. The typical total divergence is the full angle measured where the luminous intensity is half of the peak value.