

SPECIFICATION FOR APPROVAL

1、外观尺寸图(PHYSICAL DIMENTION)

(UNIT:mm)

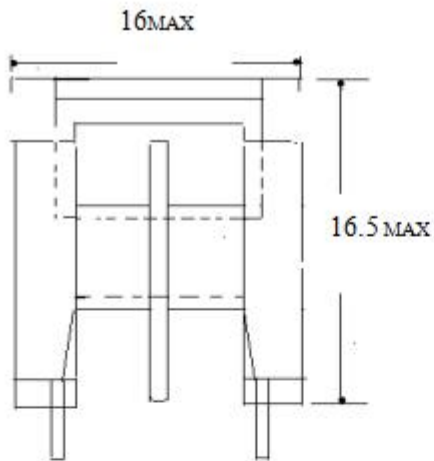

ELEVATION VIEW

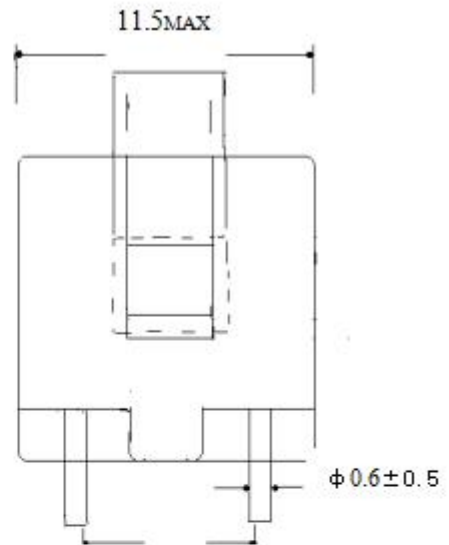

SIDE VIEW

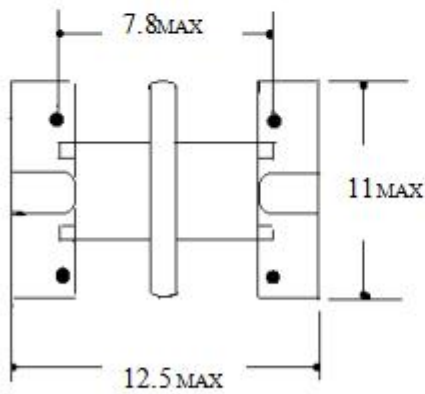

Bottom View

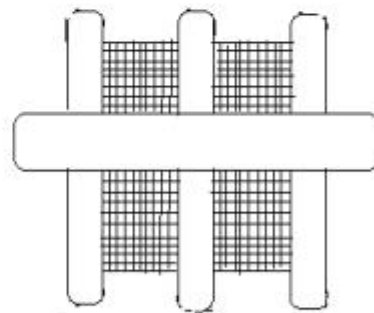

Top View

--	--	--	--	--	--



SPECIFICATION FOR APPROVAL

5、电气参数(ELECTRICAL CHARACTERISTIC)

TEST ITEMS	INSTRUMENT	TEST CONDITON	TEST	LIMITS
INDUCTANCE	CHEN HWA100	FREQ 1KHz/0.3V	L(1-3)	22MHmin(1K0.3V)
			L(4-5)	22MHmin(1K0.3V))
INDUCTANCE	CHEN HWA310			
DIELECTRIS STRENGTH	CHEN HWA901	1MINUTE/5mA	PRI- SEC	1500V/AC
			PRI- CORE	1500V/AC
			SEC- CORE	1500V/AC
Q 值	CHEN HWA100			
LEAKAGE	CHEN HWA100	OTHER SHORT FREQ 1KHz/0.25V		
D.C.R (Ref)	CHEN HWA502	@25AC		

INSULATTON RESISTANCE:

THE INSULATTON RESISANCE BETWEEN PRI TOSEC AND CORE IS OVER 100MOHM AT DC500V。

THEMP POPPERTY:

BETWEEN-20AC 80AC, TEST THE INDUCTANCE AND DC RESISTANCE ON THE BASIS25AC。

THE VARITION SHALL NOT EXCEED20%。