

Switch >> Toggle switch Series

KLS7-MS-102-A1 (Miniature type)

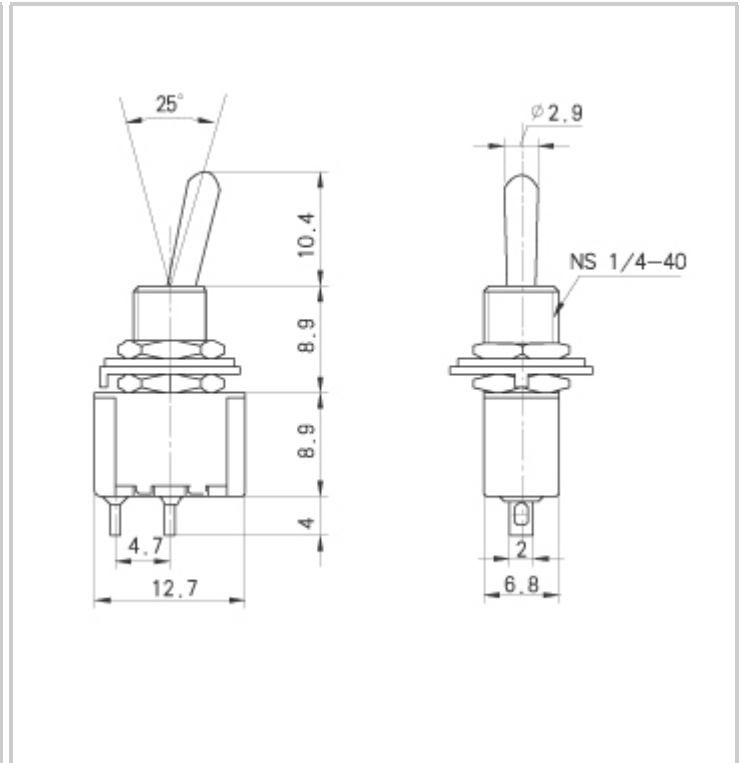

Contact Rating:	5A125V AC / 2A 250V AC
Electrical Life:	30000 Cycles
Contact resistance:	10m Ω max
Insulator resistance:	1000M Ω min
Dielectric Strength:	1500V RMS@ Sea Level
Operating Temperature:	-45 $\text{ }^{\circ}\text{C}$ ~ +85 $\text{ }^{\circ}\text{C}$
Standard:	UL VDE CE CQC ROHS



KLS7-MS-101-A1 / ON-OFF

KLS7-MS-111-A1 / (ON)-OFF

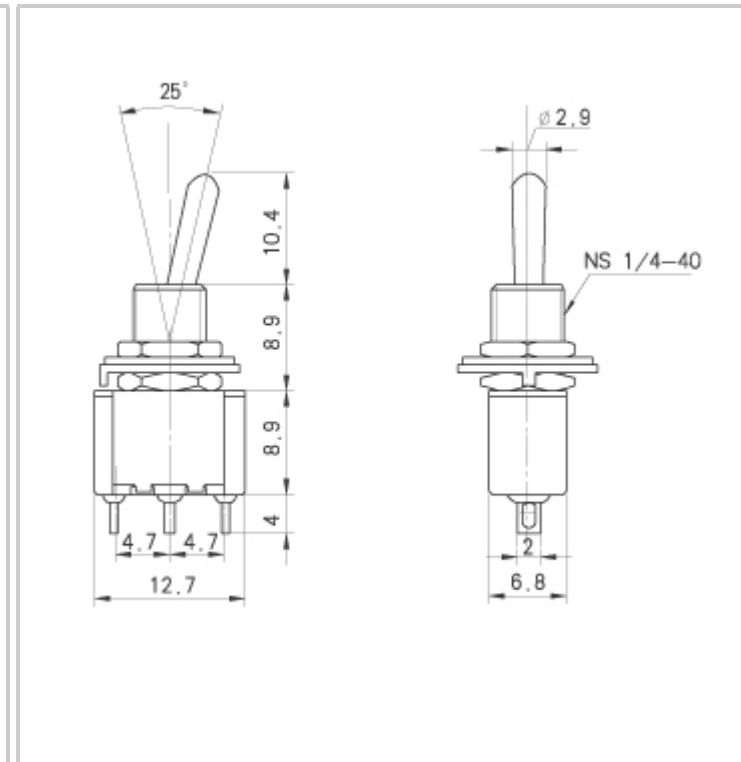

KLS7-MS-102-A1 ON-ON
KLS7-MS-112-A1 ON-(ON)

KLS7-MS-103-A1 ON-OFF-ON
KLS7-MS-113-A1 ON-OFF-(ON)
KLS7-MS-123-A1 (ON)-OFF-(ON)



KLS7-MS-101-A2 / ON-OFF

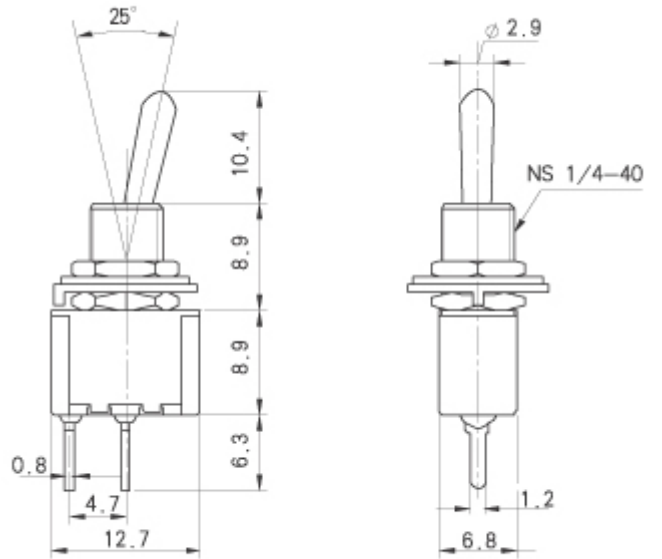

KLS7-MS-111-A2 / (ON)-OFF



KLS7-MS-102-A2 ON-ON
KLS7-MS-112-A2 ON-(ON)

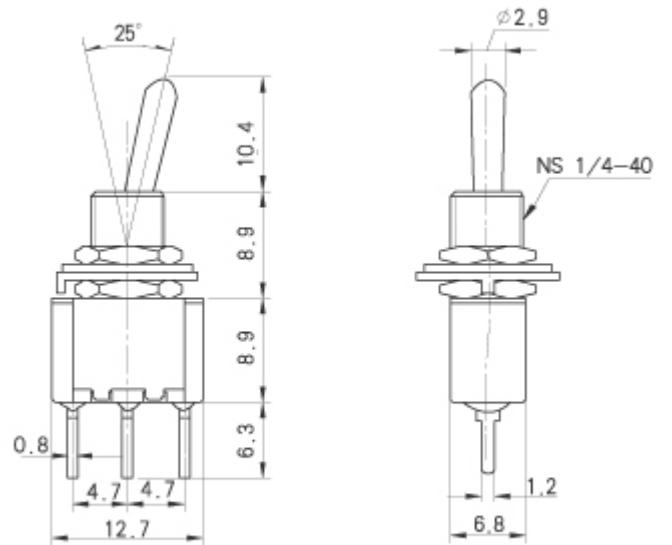

KLS7-MS-103-A2 ON-OFF-ON
KLS7-MS-113-A2 ON-OFF-(ON)
KLS7-MS-123-A2 (ON)-OFF-(ON)