

**Piezo Transducer Series**

**KLS3-PT-12\*06 Without Circuit Piezo Transducer Buzzer Series**

Order Code	KLS3-PT-12*06-A	KLS3-PT-12*06-B
Rated Voltage	5Vp-p	12Vp-p
Max.Allowable Voltage	30Vp-p	30Vp-p
Max. Rated Current	3mA	6mA
Resonant Frequency	4.0±0.5KHz	4.0±0.5KHz
Min.S.P.L. ( @10cm )	75dB	80dB
Capacitance at 1,000Hz	11000±30% Pf	11000±30% Pf
Operating Temp	-20°C~+70°C	-20°C~+70°C
Weight	1.2g	1.2g

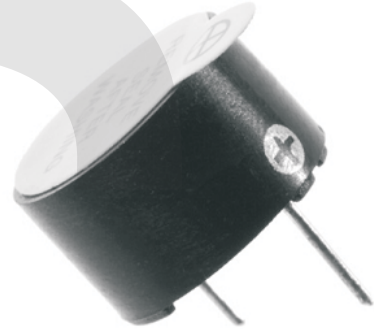

Dimensions (Unit:mm)

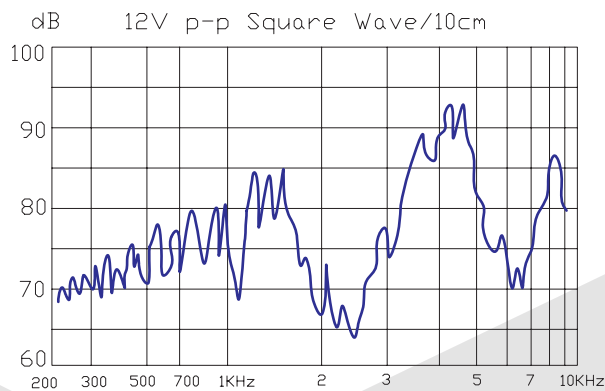
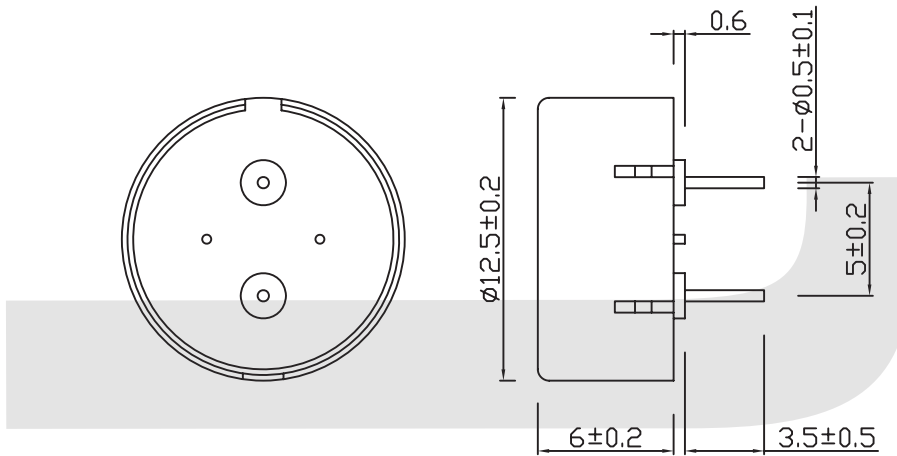

**ORDER INFORMATION**

Product No.: **KLS3 - PT - 12\*06-A**

Part Number   
Without Circuit Piezo Transducer Buzzer Series  Order Code