

AA5060SEC/H

HYPER ORANGE

### Features

- SINGLE COLOR.
- SUITABLE FOR ALL SMT ASSEMBLY AND SOLDER PROCESS.
- AVAILABLE ON TAPE AND REEL.
- IDEAL FOR BACKLIGHTING.
- PACKAGE : 500PCS / REEL.
- RoHS COMPLIANT.

### Description

This devices are made with TS InGaAlP.

### Package Dimensions

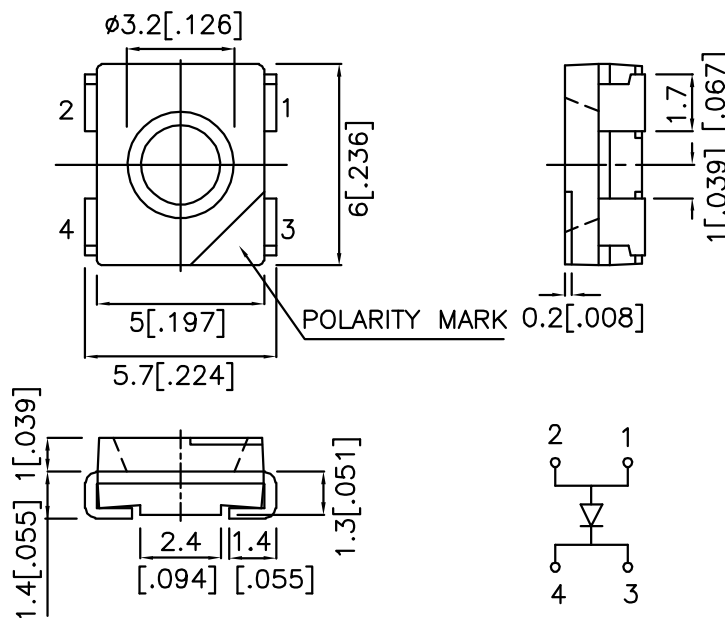

#### Notes:

1. All dimensions are in millimeters (inches).
2. Tolerance is  $\pm 0.25$  (0.01") unless otherwise noted.
3. Specifications are subject to change without notice.

## Selection Guide

Part No.	Dice	Lens Type	Iv (mcd) @ 50mA		Viewing Angle
			Min.	Typ.	θ1/2
AA5060SEC/H	HYPERS ORANGE (InGaAlP)	WATER CLEAR	1500	2300	100°

Note:

1. θ1/2 is the angle from optical centerline where the luminous intensity is 1/2 the optical centerline value.

## Electrical / Optical Characteristics at TA=25°C

Symbol	Parameter	Device	Typ.	Max.	Units	Test Conditions
λpeak	Peak Wavelength	Hyper Orange	640		nm	IF=20mA
λD	Dominant Wavelength	Hyper Orange	630		nm	IF=20mA
Δλ1/2	Spectral Line Half-width	Hyper Orange	25		nm	IF=20mA
C	Capacitance	Hyper Orange	27		pF	VF=0V;f=1MHz
VF	Forward Voltage	Hyper Orange	2.2	2.8	V	IF=20mA
IR	Reverse Current	Hyper Orange		10	uA	VR= 5V

## Absolute Maximum Ratings at TA=25°C

Parameter	Hyper Orange	Units
Power dissipation	140	mW
DC Forward Current	50	mA
Peak Forward Current [1]	150	mA
Reverse Voltage	5	V
Operating/Storage Temperature	-40°C To +85°C	

Note:

1. 1/10 Duty Cycle, 0.1ms Pulse Width.

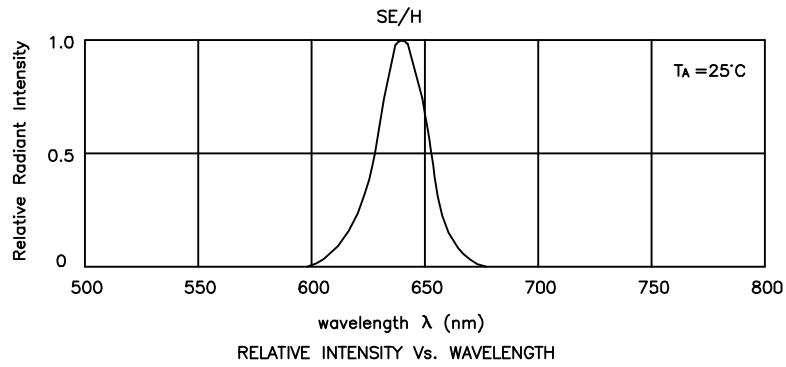

## Hyper Orange

### AA5060SEC/H

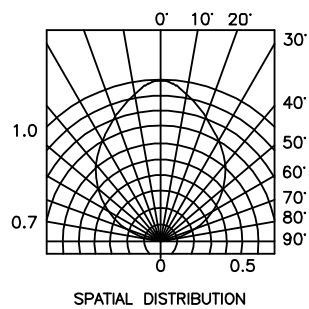
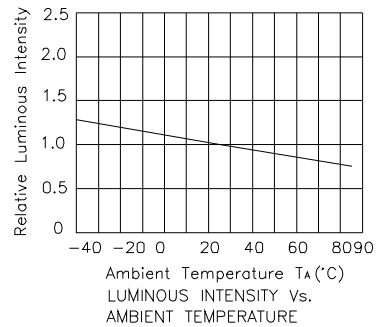
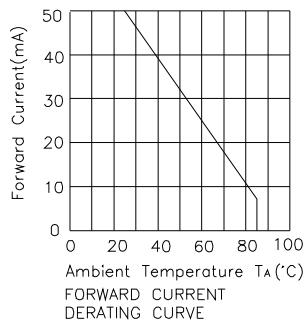
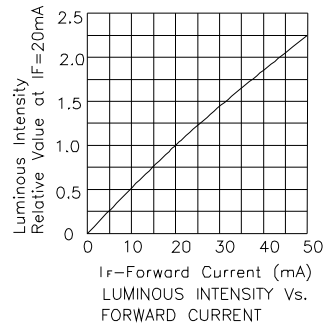
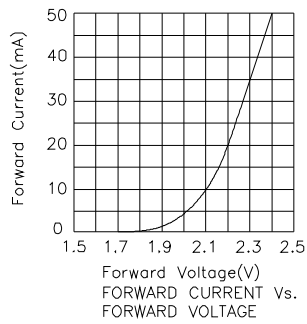

## AA5060SEC/H

Reflow Soldering Profile For Lead-free SMT Process.

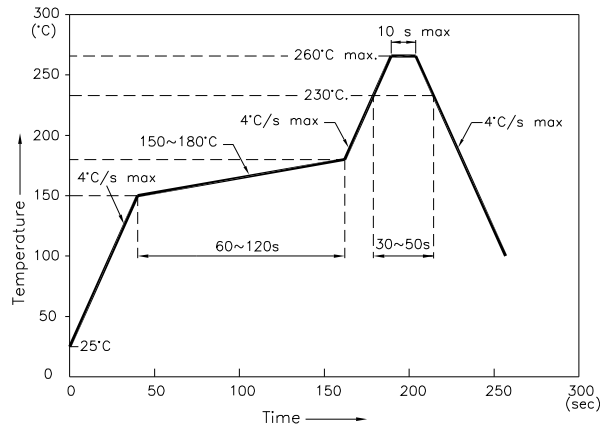

**NOTES:**

1. We recommend the reflow temperature 245°C(+/-5°C). The maximum soldering temperature should be limited to 260°C.
2. Don't cause stress to the epoxy resin while it is exposed to high temperature.
3. Number of reflow process shall be 2 times or less.

### Recommended Soldering Pattern (Units : mm)

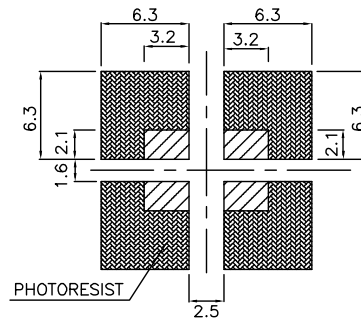

### Tape Specifications (Units : mm)

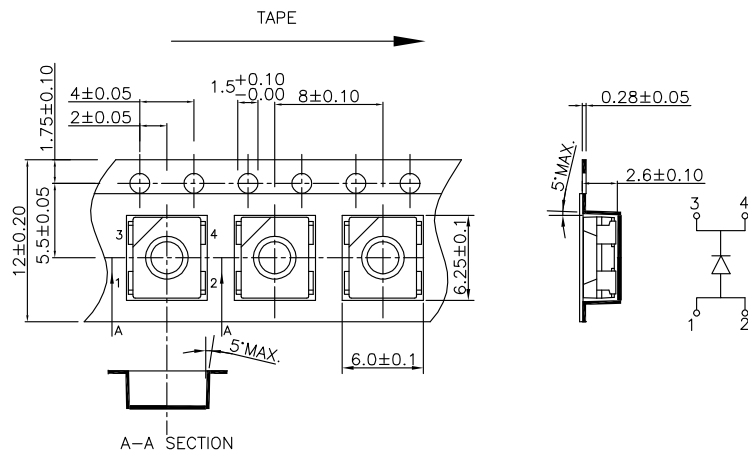

If special sorting is required (e.g. binning based on forward voltage, luminous intensity, or wavelength), the typical accuracy of the sorting process is as follows:

1. Wavelength: +/-1nm
2. Luminous Intensity: +/-15%
3. Forward Voltage: +/-0.1V

Note: Accuracy may depend on the sorting parameters.