

Power Inductor Wire Wound(NR) Type

HPIT Series

Ferrite 252010/252012 Size



Ordering Information

HPIT 252012 - 1R0 M - LF

(1) (2) (3) (4) (5)

- (1) Series Name
- (2) Product Dimension (L*W mm)
- (3) Inductance Value (1R0:1.0uH / 100:10uH / 101:100uH)
- (4) Inductance Tolerance (K: ± 10% / M: ± 20% / N: ± 30%)
- (5) Lead Free Product

Shape & Dimensions

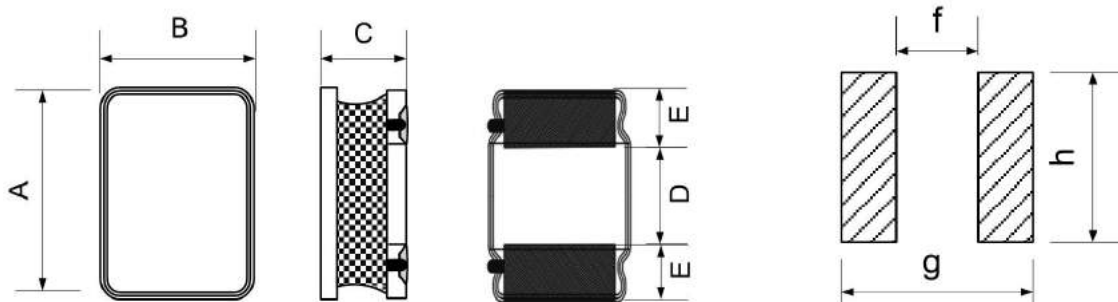

Recommended Pattern

Size	Dimensions (mm)							
	A	B	C	D	E	f	g	h
252010	2.50±0.20	2.00±0.20	1.00 (Max.)	0.80±0.2	0.80±0.2	0.80 (Typ.)	2.50 (Typ.)	2.00 (Typ.)
252012	2.50±0.20	2.00±0.20	1.20 (Max.)	0.80±0.2	0.80±0.2	0.80 (Typ.)	2.50 (Typ.)	2.00 (Typ.)

Material List

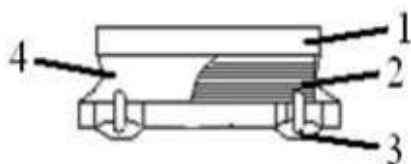

No.	Item	Material
1	Core	Ni-Zn Ferrite
2	Wire	Enameled Copper Wire
3	Terminal Electrode	Ag/Ni/Sn/Cu
4	Magnetic Glue	Epoxy resin and magnetic powder



Power Inductor Wire Wound(NR) Type HPIT Series Ferrite 252010/252012 Size

Electrical Characteristics

HPIT252010 Size

HONGDA Part No.	Inductance (μ H)	DCR (Ω)		Isat (A)		Irms (A)	
		Max.	Typ.	Max.	Typ.	Max.	Typ.
HPIT252010-R47M-LF	0.47 \pm 20%	0.056	0.047	3.20	3.40	2.43	2.70
HPIT252010-R68M-LF	0.68 \pm 20%	0.056	0.047	2.50	2.90	2.43	2.70
HPIT252010-1R0M-LF	1.0 \pm 20%	0.078	0.065	1.85	2.55	2.05	2.30
HPIT252010-2R2M-LF	2.2 \pm 20%	0.186	0.155	1.55	1.70	1.45	1.65
HPIT252010-3R3M-LF	3.3 \pm 20%	0.300	0.250	1.15	1.30	1.25	1.45
HPIT252010-4R7M-LF	4.7 \pm 20%	0.456	0.380	1.10	1.20	0.85	0.90
HPIT252010-6R8M-LF	6.8 \pm 20%	0.540	0.450	0.90	1.00	0.80	0.85
HPIT252010-100M-LF	10 \pm 20%	0.660	0.550	0.80	0.90	0.60	0.70
HPIT252010-220M-LF	22 \pm 20%	1.600	1.450	0.55	0.60	0.45	0.55
HPIT252010-470M-LF	47 \pm 20%	2.400	2.000	0.28	0.35	0.28	0.35

HPIT252012 Size

HONGDA Part No.	Inductance (μ H)	DCR (Ω)		Isat (A)		Irms (A)	
		Max.	Typ.	Max.	Typ.	Max.	Typ.
HPIT252012-R47M-LF	0.47 \pm 20%	0.035	0.029	3.80	4.20	3.00	3.30
HPIT252012-R68M-LF	0.68 \pm 20%	0.048	0.040	3.00	3.40	2.50	2.80
HPIT252012-1R0M-LF	1.0 \pm 20%	0.065	0.050	1.70	1.90	2.43	2.70
HPIT252012-1R5M-LF	1.5 \pm 20%	0.088	0.065	1.80	2.00	1.95	2.10
HPIT252012-2R2M-LF	2.2 \pm 20%	0.144	0.110	1.55	1.85	1.70	1.85
HPIT252012-3R3M-LF	3.3 \pm 20%	0.174	0.133	1.30	1.45	1.35	1.45
HPIT252012-4R7M-LF	4.7 \pm 20%	0.252	0.210	1.25	1.30	1.12	1.25
HPIT252012-5R6M-LF	5.6 \pm 20%	0.273	0.210	0.95	1.10	0.90	1.00
HPIT252012-6R8M-LF	6.8 \pm 20%	0.360	0.300	0.90	1.05	0.85	0.95
HPIT252012-100M-LF	10 \pm 20%	0.600	0.500	0.75	0.85	0.70	0.80
HPIT252012-150M-LF	15 \pm 20%	0.720	0.600	0.55	0.70	0.60	0.70
HPIT252012-220M-LF	22 \pm 20%	1.150	0.960	0.50	0.55	0.50	0.60

Power Inductor Wire Wound(NR) Type

HPIT Series

Ferrite 3010/3012/3015 Size

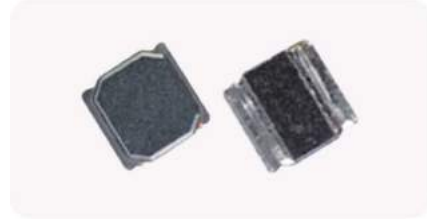

Ordering Information

HPIT 3010 - 1R0 M - LF

(1) (2) (3) (4) (5)

- (1) Series Name
- (2) Product Dimension (L*W mm)
- (3) Inductance Value (1R0:1.0uH / 100:10uH / 101:100uH)
- (4) Inductance Tolerance (K: ± 10% / M: ± 20% / N: ± 30%)
- (5) Lead Free Product

Shape & Dimensions

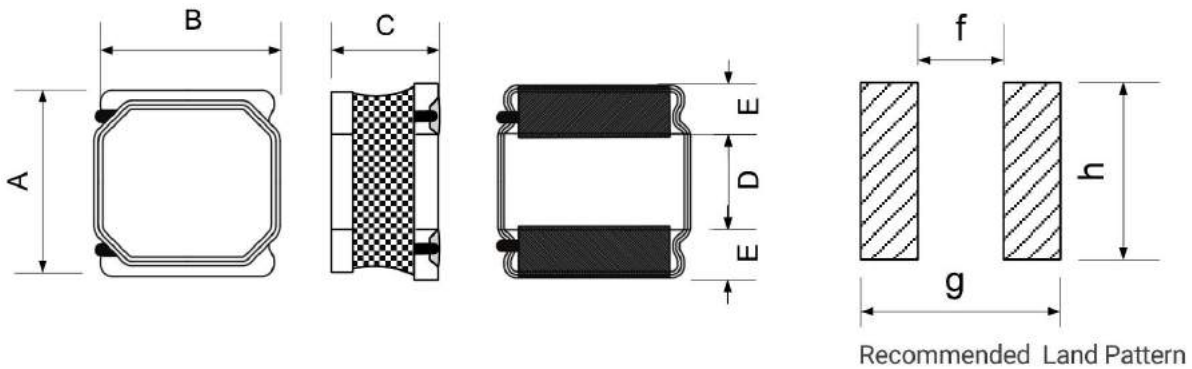

Size	Dimensions (mm)							
	A	B	C	D	E	f	g	h
3010	3.00±0.20	3.00±0.20	1.00Max.	1.20±0.2	0.90±0.2	1.50 (Typ.)	3.10 (Typ.)	2.70 (Typ.)
3012	3.00±0.20	3.00±0.20	1.20Max.	1.20±0.2	0.90±0.2	1.50 (Typ.)	3.10 (Typ.)	2.70 (Typ.)
3015	3.00±0.20	3.00±0.20	1.50Max.	1.20±0.2	0.90±0.2	1.50 (Typ.)	3.10 (Typ.)	2.70 (Typ.)

Material List

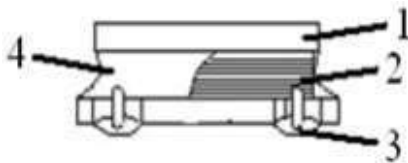

No.	Item	Material
1	Core	Ni-Zn Ferrite
2	Wire	Enameled Copper Wire
3	Terminal Electrode	Ag/Ni/Sn/Cu
4	Magnetic Glue	Epoxy resin and magnetic powder

Power Inductor Wire Wound(NR) Type

HPIT Series Ferrite 3010 Size

Electrical Characteristics

HPIT3010 Size

HONGDA Part No.	Inductance (μ H)	DCR (Ω)		Isat (A)		Irms (A)	
		Max.	Typ.	Max.	Typ.	Max.	Typ.
HPIT3010-R56M-LF	0.56 \pm 20%	0.048	0.040	2.50	2.80	2.00	2.15
HPIT3010-R68M-LF	0.68 \pm 20%	0.048	0.040	2.30	2.50	2.00	2.15
HPIT3010-1R0M-LF	1.0 \pm 20%	0.066	0.055	1.95	2.15	1.75	2.00
HPIT3010-1R5M-LF	1.5 \pm 20%	0.078	0.065	1.50	1.65	1.55	1.70
HPIT3010-2R2M-LF	2.2 \pm 20%	0.130	0.100	1.20	1.50	1.10	1.40
HPIT3010-3R3M-LF	3.3 \pm 20%	0.145	0.120	1.10	1.20	1.15	1.25
HPIT3010-4R7M-LF	4.7 \pm 20%	0.222	0.185	0.95	1.10	0.95	1.05
HPIT3010-6R8M-LF	6.8 \pm 20%	0.330	0.275	0.75	0.85	0.65	0.70
HPIT3010-8R2M-LF	8.2 \pm 20%	0.348	0.290	0.70	0.80	0.70	0.80
HPIT3010-100M-LF	10 \pm 20%	0.480	0.380	0.65	0.70	0.65	0.70
HPIT3010-150M-LF	15 \pm 20%	0.624	0.520	0.50	0.60	0.50	0.60
HPIT3010-220M-LF	22 \pm 20%	1.000	0.800	0.40	0.50	0.40	0.50
HPIT3010-330M-LF	33 \pm 20%	1.200	1.000	0.30	0.40	0.30	0.40

HPIT3012 Size

HONGDA Part No.	Inductance (μ H)	DCR (Ω)		Isat (A)		Irms (A)	
		Max.	Typ.	Max.	Typ.	Max.	Typ.
HPIT3012-R47M-LF	0.47 \pm 20%	0.030	0.025	3.50	4.00	2.80	3.10
HPIT3012-R82M-LF	0.82 \pm 20%	0.039	0.030	2.40	2.60	2.60	3.30
HPIT3012-1R0M-LF	1.0 \pm 20%	0.048	0.040	2.20	2.50	2.60	3.30
HPIT3012-1R2M-LF	1.2 \pm 20%	0.048	0.040	1.85	2.15	2.25	2.60
HPIT3012-1R5M-LF	1.5 \pm 20%	0.060	0.050	2.00	2.10	2.00	2.30
HPIT3012-2R2M-LF	2.2 \pm 20%	0.075	0.062	1.40	1.65	1.85	2.10
HPIT3012-3R3M-LF	3.3 \pm 20%	0.108	0.090	1.25	1.45	1.50	1.70
HPIT3012-4R7M-LF	4.7 \pm 20%	0.156	0.120	1.00	1.20	1.24	1.30
HPIT3012-6R8M-LF	6.8 \pm 20%	0.210	0.175	0.90	1.05	1.05	1.15
HPIT3012-100M-LF	10 \pm 20%	0.330	0.260	0.65	0.75	0.83	1.00
HPIT3012-150M-LF	15 \pm 20%	0.420	0.350	0.50	0.60	0.75	0.85
HPIT3012-180M-LF	18 \pm 20%	0.576	0.480	0.50	0.60	0.68	0.78
HPIT3012-220M-LF	22 \pm 20%	0.588	0.490	0.45	0.50	0.65	0.75
HPIT3012-330M-LF	33 \pm 20%	0.960	0.800	0.40	0.47	0.50	0.55
HPIT3012-470M-LF	47 \pm 20%	1.560	1.300	0.35	0.45	0.40	0.45

Power Inductor Wire Wound(NR) Type

HPIT Series Ferrite 3015 Size

Electrical Characteristics

HPIT3015 Size

HONGDA Part No.	Inductance (μ H)	DCR (Ω)		Isat (A)		Irms (A)	
		Max.	Typ.	Max.	Typ.	Max.	Typ.
HPIT3015-R22M-LF	0.22 \pm 20%	0.012	0.009	6.50	6.90	6.00	6.50
HPIT3015-R24M-LF	0.24 \pm 20%	0.012	0.009	5.50	6.00	5.50	6.00
HPIT3015-R47M-LF	0.47 \pm 20%	0.021	0.018	4.00	4.10	4.00	4.20
HPIT3015-1R0M-LF	1.0 \pm 20%	0.040	0.030	2.65	2.80	2.65	2.85
HPIT3015-1R2M-LF	1.2 \pm 20%	0.048	0.040	2.60	2.80	2.40	2.65
HPIT3015-1R5M-LF	1.5 \pm 20%	0.055	0.045	2.55	2.75	2.30	2.60
HPIT3015-2R2M-LF	2.2 \pm 20%	0.072	0.060	1.95	2.10	2.10	2.25
HPIT3015-3R3M-LF	3.3 \pm 20%	0.102	0.085	1.65	1.75	1.75	1.85
HPIT3015-3R9M-LF	3.9 \pm 20%	0.132	0.110	1.40	1.50	1.60	1.70
HPIT3015-4R7M-LF	4.7 \pm 20%	0.145	0.120	1.35	1.45	1.40	1.50
HPIT3015-5R6M-LF	5.6 \pm 20%	0.156	0.130	1.00	1.20	1.40	1.50
HPIT3015-6R8M-LF	6.8 \pm 20%	0.200	0.170	1.00	1.15	1.20	1.30
HPIT3015-8R2M-LF	8.2 \pm 20%	0.228	0.190	0.85	1.05	1.10	1.20
HPIT3015-100M-LF	10 \pm 20%	0.300	0.250	1.00	1.10	1.00	1.05
HPIT3015-120M-LF	12 \pm 20%	0.300	0.250	0.75	0.85	1.00	1.05
HPIT3015-150M-LF	15 \pm 20%	0.420	0.350	0.70	0.80	0.85	0.95
HPIT3015-220M-LF	22 \pm 20%	0.545	0.440	0.55	0.65	0.75	0.85
HPIT3015-330M-LF	33 \pm 20%	0.852	0.710	0.45	0.50	0.60	0.65
HPIT3015-470M-LF	47 \pm 20%	1.200	1.000	0.40	0.45	0.50	0.55
HPIT3015-680M-LF	68 \pm 20%	2.400	2.000	0.32	0.34	0.35	0.40
HPIT3015-101M-LF	100 \pm 20%	4.040	3.110	0.23	0.25	0.21	0.25
HPIT3015-221M-LF	220 \pm 20%	6.200	5.000	0.13	0.15	0.085	0.085

Power Inductor Wire Wound(NR) Type

HPIT Series

Ferrite 4012/4018/4020/4030 Size



Ordering Information

HPIT **4018** - **1R0** **M** - **LF**
 (1) (2) (3) (4) (5)

- (1) Series Name
- (2) Product Dimension (L*W mm)
- (3) Inductance Value (1R0:1.0uH / 100:10uH / 101:100uH)
- (4) Inductance Tolerance (K: ± 10% / M: ± 20% / N: ± 30%)
- (5) Lead Free Product

Shape & Dimensions

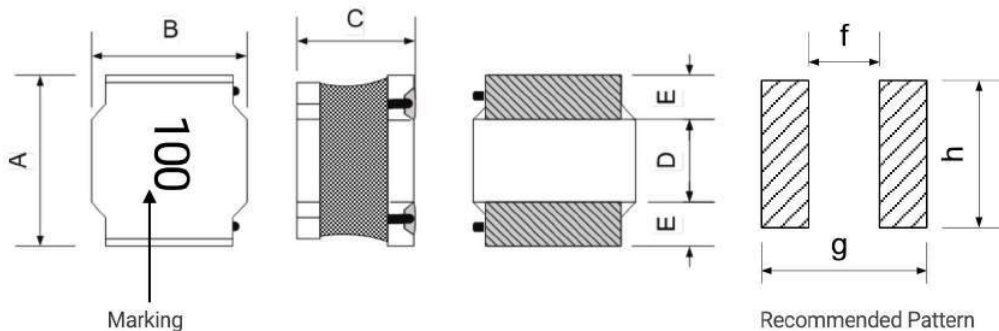

Size	Dimensions (mm)							
	A	B	C	D	E	f	g	h
4012	4.00±0.20	4.00±0.20	1.80Max.	2.10±0.2	0.95±0.2	1.90 (Typ.)	4.10 (Typ.)	3.70 (Typ.)
4018	4.00±0.20	4.00±0.20	1.80Max.	2.10±0.2	0.95±0.2	1.90 (Typ.)	4.10 (Typ.)	3.70 (Typ.)
4020	4.00±0.20	4.00±0.20	2.00Max.	2.10±0.2	0.95±0.2	1.90 (Typ.)	4.10 (Typ.)	3.70 (Typ.)
4030	4.00±0.20	4.00±0.20	3.00Max.	2.10±0.2	0.95±0.2	1.90 (Typ.)	4.10 (Typ.)	3.70 (Typ.)

Material List

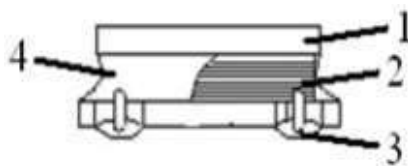

No.	Item	Material
1	Core	Ni-Zn Ferrite
2	Wire	Enameled Copper Wire
3	Terminal Electrode	Ag/Ni/Sn/Cu
4	Magnetic Glue	Epoxy resin and magnetic powder



Power Inductor Wire Wound(NR) Type HPIT Series Ferrite 4012 Size

Electrical Characteristics

HPIT4012 Size

HONGDA Part No.	Inductance (uH)	DCR (Ω)		Isat (A)		Irms (A)	
		Max.	Typ.	Max.	Typ.	Max.	Typ.
HPIT4012-R82M-LF	0.82 ±20%	0.065	0.050	3.45	3.65	2.00	2.20
HPIT4012-1R0M-LF	1.0 ±20%	0.065	0.050	3.00	3.20	2.00	2.20
HPIT4012-1R5M-LF	1.5 ±20%	0.078	0.065	2.30	2.50	1.90	2.00
HPIT4012-2R2M-LF	2.2 ±20%	0.104	0.087	2.00	2.10	1.85	2.10
HPIT4012-3R3M-LF	3.3 ±20%	0.143	0.110	1.80	1.95	1.50	1.70
HPIT4012-4R7M-LF	4.7 ±20%	0.182	0.140	1.40	1.55	1.35	1.50
HPIT4012-5R6M-LF	5.6 ±20%	0.215	0.165	1.50	1.60	1.25	1.35
HPIT4012-6R8M-LF	6.8 ±20%	0.257	0.198	1.25	1.40	1.15	1.30
HPIT4012-100M-LF	10 ±20%	0.312	0.240	0.90	1.05	0.95	1.05
HPIT4012-150M-LF	15 ±20%	0.494	0.380	0.70	0.90	0.80	0.90
HPIT4012-220M-LF	22 ±20%	0.741	0.570	0.60	0.70	0.67	0.75
HPIT4012-330M-LF	33 ±20%	1.050	0.810	0.45	0.69	0.45	0.50
HPIT4012-470M-LF	47 ±20%	1.760	1.350	0.40	0.45	0.40	0.45
HPIT4012-101M-LF	100 ±20%	3.600	3.000	0.30	0.35	0.28	0.30

HPIT4018 Size

HONGDA Part No.	Inductance (uH)	DCR (Ω)		Isat (A)		Irms (A)	
		Max.	Typ.	Max.	Typ.	Max.	Typ.
HPIT4018-R24M-LF	0.24 ±20%	0.016	0.012	6.50	7.00	4.60	5.00
HPIT4018-R68M-LF	0.68 ±20%	0.025	0.021	6.00	7.00	3.80	4.15
HPIT4018-1R0M-LF	1.0 ±20%	0.030	0.025	4.55	4.85	3.40	3.80
HPIT4018-1R2M-LF	1.2 ±20%	0.030	0.025	4.20	4.80	3.40	3.80
HPIT4018-1R5M-LF	1.5 ±20%	0.036	0.030	3.90	4.25	2.95	3.20
HPIT4018-2R2M-LF	2.2 ±20%	0.048	0.040	3.15	3.40	2.60	2.90
HPIT4018-2R7M-LF	2.7 ±20%	0.060	0.050	2.70	3.00	2.20	2.50
HPIT4018-3R3M-LF	3.3 ±20%	0.060	0.050	2.70	3.00	2.20	2.50
HPIT4018-3R9M-LF	3.9 ±20%	0.078	0.065	2.60	2.80	2.00	2.20
HPIT4018-4R7M-LF	4.7 ±20%	0.078	0.065	2.10	2.30	2.00	2.20
HPIT4018-6R8M-LF	6.8 ±20%	0.108	0.090	1.70	1.85	1.70	1.90
HPIT4018-100M-LF	10 ±20%	0.168	0.140	1.40	1.55	1.20	1.30
HPIT4018-150M-LF	15 ±20%	0.228	0.190	1.15	1.25	1.00	1.20
HPIT4018-220M-LF	22 ±20%	0.336	0.280	1.00	1.10	0.95	1.10
HPIT4018-330M-LF	33 ±20%	0.480	0.400	0.80	0.90	0.75	0.85
HPIT4018-470M-LF	47 ±20%	0.720	0.600	0.70	0.80	0.60	0.70
HPIT4018-560M-LF	56 ±20%	0.912	0.760	0.65	0.80	0.53	0.58
HPIT4018-101M-LF	100 ±20%	1.740	1.450	0.45	0.55	0.30	0.35
HPIT4018-221M-LF	220 ±20%	3.600	3.000	0.30	0.34	0.21	0.23



Power Inductor Wire Wound(NR) Type HPIT Series Ferrite 4020 Size

Electrical Characteristics

HPIT4020 Size

HONGDA Part No.	Inductance (uH)	DCR (Ω)		Isat (A)		Irms (A)	
		Max.	Typ.	Max.	Typ.	Max.	Typ.
HPIT4020-1R0M-LF	1.0±20%	0.042	0.032	4.78	5.10	3.50	4.00
HPIT4020-1R2M-LF	1.2±20%	0.048	0.040	4.50	4.70	3.40	3.80
HPIT4020-2R2M-LF	2.2±20%	0.052	0.040	3.04	3.80	1.85	2.10
HPIT4020-4R7M-LF	4.7±20%	0.098	0.075	2.35	2.50	1.34	2.00
HPIT4020-6R8M-LF	6.8±20%	0.172	0.135	2.15	2.30	1.50	1.70
HPIT4020-150M-LF	15±20%	0.299	0.230	1.35	1.50	0.77	0.85
HPIT4020-220M-LF	22±20%	0.455	0.350	1.05	1.10	0.62	0.87
HPIT4020-330M-LF	33±20%	0.715	0.520	0.85	0.95	0.49	0.53

Power Inductor Wire Wound(NR) Type

HPIT Series Ferrite 4030 Size

Electrical Characteristics

HPIT4030 Size

HONGDA Part No.	Inductance (uH)	DCR (Ω)		Isat (A)		Irms (A)	
		Max.	Typ.	Max.	Typ.	Max.	Typ.
HPIT4030-R91M-LF	0.91 \pm 20%	0.017	0.013	7.00	8.00	4.15	4.70
HPIT4030-1R0M-LF	1.0 \pm 20%	0.018	0.014	6.50	7.20	4.15	4.70
HPIT4030-1R2M-LF	1.2 \pm 20%	0.020	0.015	6.00	6.80	3.82	4.20
HPIT4030-1R5M-LF	1.5 \pm 20%	0.026	0.020	5.50	6.50	3.34	3.60
HPIT4030-1R8M-LF	1.8 \pm 20%	0.033	0.025	5.50	5.80	3.20	3.30
HPIT4030-2R2M-LF	2.2 \pm 20%	0.039	0.030	5.00	5.40	2.95	3.20
HPIT4030-3R3M-LF	3.3 \pm 20%	0.052	0.040	3.60	4.20	2.40	2.65
HPIT4030-3R9M-LF	3.9 \pm 20%	0.072	0.057	3.30	3.80	2.10	2.30
HPIT4030-4R7M-LF	4.7 \pm 20%	0.078	0.060	2.70	3.20	2.00	2.20
HPIT4030-5R6M-LF	5.6 \pm 20%	0.085	0.065	2.70	2.90	1.95	2.10
HPIT4030-6R8M-LF	6.8 \pm 20%	0.109	0.084	2.30	2.80	1.65	1.80
HPIT4030-8R2M-LF	8.2 \pm 20%	0.109	0.084	2.10	2.35	1.65	1.80
HPIT4030-100M-LF	10 \pm 20%	0.125	0.096	1.80	2.20	1.52	1.65
HPIT4030-120M-LF	12 \pm 20%	0.170	0.131	1.65	2.10	1.30	1.45
HPIT4030-150M-LF	15 \pm 20%	0.245	0.189	1.60	1.90	1.11	1.20
HPIT4030-220M-LF	22 \pm 20%	0.295	0.225	1.10	1.50	1.00	1.10
HPIT4030-330M-LF	33 \pm 20%	0.415	0.320	1.00	1.30	0.85	0.95
HPIT4030-390M-LF	39 \pm 20%	0.450	0.345	1.03	1.10	0.80	0.90
HPIT4030-470M-LF	47 \pm 20%	0.580	0.445	0.75	1.05	0.72	0.80
HPIT4030-560M-LF	56 \pm 20%	0.720	0.555	0.85	0.95	0.65	0.70
HPIT4030-620M-LF	62 \pm 20%	1.080	0.829	0.80	0.85	0.53	0.60
HPIT4030-680M-LF	68 \pm 20%	1.130	0.868	0.70	0.85	0.52	0.55
HPIT4030-101M-LF	100 \pm 20%	1.450	1.110	0.60	0.75	0.45	0.50
HPIT4030-121M-LF	120 \pm 20%	1.630	1.250	0.53	0.60	0.43	0.47
HPIT4030-151M-LF	150 \pm 20%	1.720	1.440	0.50	0.60	0.42	0.46
HPIT4030-181M-LF	180 \pm 20%	1.836	1.530	0.48	0.55	0.40	0.44
HPIT4030-331M-LF	330 \pm 20%	4.080	3.400	0.30	0.38	0.27	0.30

Power Inductor Wire Wound(NR) Type

HPIT Series

Ferrite 5020 Size

Ordering Information

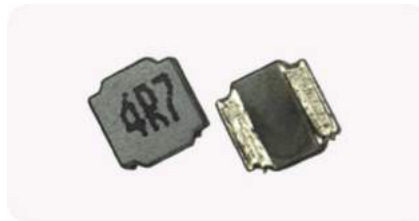

HPIT 5020 - 1R0 M - LF

(1) (2) (3) (4) (5)

- (1) Series Name
- (2) Product Dimension (L*W mm)
- (3) Inductance Value (1R0:1.0uH / 100:10uH / 101:100uH)
- (4) Inductance Tolerance (K: ± 10% / M: ± 20% / N: ± 30%)
- (5) Lead Free Product

Shape & Dimensions

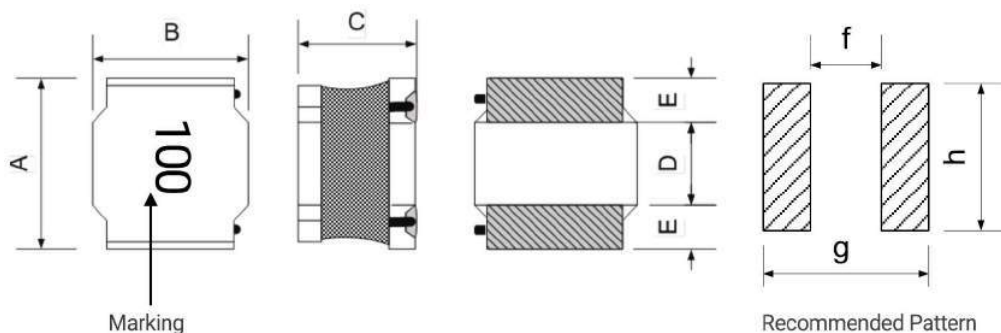

Dimensions (mm)							
A	B	C	D	E	f	g	h
5.0±0.20	5.0±0.20	2.1 (Max.)	2.5±0.3	1.25±0.3	2.40 (Typ.)	5.10 (Typ.)	4.70 (Typ.)

Material List

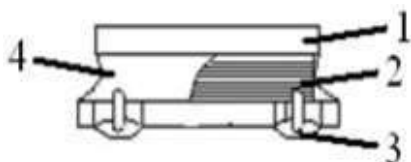

No.	Item	Material
1	Core	Ni-Zn Ferrite
2	Wire	Enameled Copper Wire
3	Terminal Electrode	Ag/Ni/Sn/Cu
4	Magnetic Glue	Epoxy resin and magnetic powder

Power Inductor Wire Wound(NR) Type

HPIT Series Ferrite 5020 Size

Electrical Characteristics

HPIT5020 Size

HONGDA Part No.	Inductance (μ H)	DCR (Ω)		Isat (A)	
		Max.	Typ.	Max.	Typ.
HPIT5020-R47N-LF	0.47 \pm 30%	0.016	0.012	8.00	8.40
HPIT5020-R68N-LF	0.68 \pm 30%	0.018	0.014	7.50	8.00
HPIT5020-1R0M-LF	1.0 \pm 20%	0.025	0.019	6.40	7.00
HPIT5020-1R5M-LF	1.5 \pm 20%	0.034	0.026	5.20	5.70
HPIT5020-2R2M-LF	2.2 \pm 20%	0.042	0.032	4.50	4.90
HPIT5020-2R7M-LF	2.7 \pm 20%	0.046	0.035	4.20	4.50
HPIT5020-3R3M-LF	3.3 \pm 20%	0.056	0.043	3.80	4.20
HPIT5020-4R7M-LF	4.7 \pm 20%	0.074	0.057	3.00	3.10
HPIT5020-5R6M-LF	5.6 \pm 20%	0.083	0.064	2.30	2.50
HPIT5020-6R8M-LF	6.8 \pm 20%	0.108	0.083	2.30	2.50
HPIT5020-100M-LF	10 \pm 20%	0.137	0.105	2.00	2.20
HPIT5020-120M-LF	12 \pm 20%	0.182	0.140	1.70	2.10
HPIT5020-150M-LF	15 \pm 20%	0.228	0.175	1.60	1.90
HPIT5020-180M-LF	18 \pm 20%	0.283	0.218	1.50	1.70
HPIT5020-220M-LF	22 \pm 20%	0.286	0.220	1.40	1.55
HPIT5020-470M-LF	47 \pm 20%	0.624	0.520	0.80	0.90
HPIT5020-101M-LF	100 \pm 20%	1.430	1.100	0.55	0.60

Power Inductor Wire Wound(NR) Type HPIT Series Ferrite 5040 Size

Electrical Characteristics

HPIT5040 Size

HONGDA Part No.	Inductance (μ H)	DCR (Ω)		Isat (A)	
		Max.	Typ.	Max.	Typ.
HPIT5040-1R0M-LF	1.0 \pm 20%	0.015	0.012	8.20	8.60
HPIT5040-1R5M-LF	1.5 \pm 20%	0.019	0.015	6.50	7.10
HPIT5040-2R2M-LF	2.2 \pm 20%	0.024	0.019	5.80	6.30
HPIT5040-2R7M-LF	2.7 \pm 20%	0.028	0.022	5.00	5.40
HPIT5040-3R3M-LF	3.3 \pm 20%	0.031	0.024	4.60	5.20
HPIT5040-3R9M-LF	3.9 \pm 20%	0.035	0.027	4.00	4.40
HPIT5040-4R7M-LF	4.7 \pm 20%	0.039	0.030	4.00	4.30
HPIT5040-6R8M-LF	6.8 \pm 20%	0.053	0.041	3.20	3.50
HPIT5040-100M-LF	10 \pm 20%	0.074	0.057	2.70	3.00
HPIT5040-150M-LF	15 \pm 20%	0.112	0.086	2.20	2.40
HPIT5040-220M-LF	22 \pm 20%	0.168	0.129	1.75	1.90
HPIT5040-270M-LF	27 \pm 20%	0.194	0.162	1.50	1.63
HPIT5040-330M-LF	33 \pm 20%	0.244	0.188	1.30	1.50
HPIT5040-470M-LF	47 \pm 20%	0.350	0.270	1.15	1.30
HPIT5040-680M-LF	68 \pm 20%	0.520	0.400	0.90	1.05
HPIT5040-101M-LF	100 \pm 20%	0.660	0.550	0.85	1.00
HPIT5040-221M-LF	220 \pm 20%	2.34	2.23	0.4	0.38
HPIT5040-681M-LF	680 \pm 20%	6.50	6.00	0.15	0.12
HPIT5040-102M-LF	1000 \pm 20%	6.00	5.50	0.24	0.21

Power Inductor Wire Wound(NR) Type

HPIT Series

Ferrite 6028 Size



Product Identification

$\frac{\text{HPIT}}{\text{①}}$ $\frac{\text{6028}}{\text{②}}$ - $\frac{\text{4R7}}{\text{③}}$ $\frac{\text{M}}{\text{④}}$ - $\frac{\text{LF}}{\text{⑤}}$

- ⌚ ① Product Symbol (T type SMD power inductor)
- ⌚ ② Product dimensions (6.0×6.0×2.8mm)
- ⌚ ③ Inductance Value: (4R7: 4.7uH 100: 10uH; 101: 100uH)
- ⌚ ④ Inductance Tolerance: (M: ±20% ; N: ±30%)
- ⌚ ⑤ Lead free product.

Appearance, Dimensions and Material

Appearance and dimensions

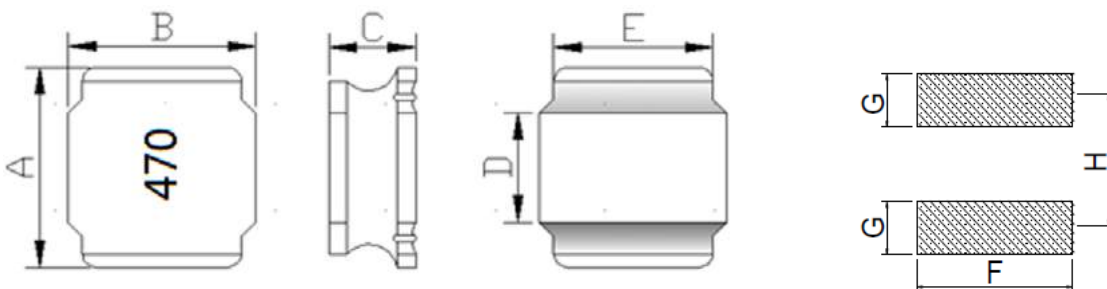

Recommended Land Pattern

Dimensions in mm								
Model	A	B	C	D	E	F	G	H
MPIT6028	6.0±0.3	6.0±0.3	2.8 Max.	2.7±0.3	4.6±0.3	5.7Typ.	1.6Typ.	4.7 Typ.

Material List

No.	Item	Material
1	Core	Ni-Zn Ferrite
2	Wire	Enameled Copper Wire
3	Terminal Electrode	Ag/Ni/Sn/Cu
4	Magnetic Glue	Epoxy resin and magnetic powder

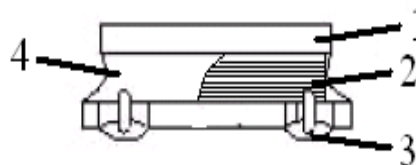

Power Inductor Wire Wound(NR) Type

HPIT Series Ferrite 6028 Size

Electrical Characteristics

HPIT6028 Size

HONGDA Part No.	Customer Part No.	Inductance	DCR	Isat	Irms
		(μ H)	(Ω) $\pm 30\%$	(A)	(A)
HPIT6028-1R0M-LF		1.0 $\pm 20\%$	0.010	5.75	5.20
HPIT6028-1R5M-LF		1.5 $\pm 20\%$	0.013	6.00	4.58
HPIT6028-1R8M-LF		1.8 $\pm 20\%$	0.016	5.50	4.10
HPIT6028-2R2M-LF		2.2 $\pm 20\%$	0.020	5.10	3.75
HPIT6028-2R7M-LF		2.7 $\pm 20\%$	0.020	3.80	3.75
HPIT6028-3R3M-LF		3.3 $\pm 20\%$	0.025	4.15	3.48
HPIT6028-4R7M-LF		4.7 $\pm 20\%$	0.030	3.00	3.08
HPIT6028-5R1M-LF		5.1 $\pm 20\%$	0.043	3.20	2.60
HPIT6028-6R2M-LF		6.2 $\pm 20\%$	0.047	3.05	2.40
HPIT6028-6R8M-LF		6.8 $\pm 20\%$	0.047	2.60	2.40
HPIT6028-8R2M-LF		8.2 $\pm 20\%$	0.055	2.30	2.25
HPIT6028-9R1M-LF		9.1 $\pm 20\%$	0.074	2.55	2.15
HPIT6028-100M-LF		10 $\pm 20\%$	0.072	2.04	1.95
HPIT6028-120M-LF		12 $\pm 20\%$	0.080	1.80	1.85
HPIT6028-150M-LF		15 $\pm 20\%$	0.125	1.75	1.45
HPIT6028-180M-LF		18 $\pm 20\%$	0.120	1.52	1.45
HPIT6028-220M-LF		22 $\pm 20\%$	0.140	1.45	1.40
HPIT6028-270M-LF		27 $\pm 20\%$	0.155	1.50	1.32
HPIT6028-330M-LF		33 $\pm 20\%$	0.185	1.35	1.22
HPIT6028-360M-LF		36 $\pm 20\%$	0.215	1.25	1.13
HPIT6028-390M-LF		39 $\pm 20\%$	0.225	1.25	1.10
HPIT6028-470M-LF		47 $\pm 20\%$	0.315	1.15	1.06
HPIT6028-680M-LF		68 $\pm 20\%$	0.360	0.80	0.86
HPIT6028-750M-LF		75 $\pm 20\%$	0.410	0.90	0.81
HPIT6028-820M-LF		82 $\pm 20\%$	0.500	0.80	0.70
HPIT6028-101M-LF		100 $\pm 20\%$	0.500	0.65	0.70

Power Inductor Wire Wound(NR) Type

HPIT Series

Ferrite 6045 Size

Ordering Information

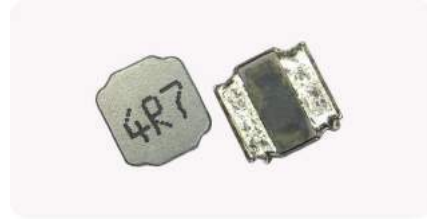

HPIT 6045 - 1R0 M - LF

(1) (2) (3) (4) (5)

- (1) Series Name
- (2) Product Dimension (L*W mm)
- (3) Inductance Value (1R0:1.0uH / 100:10uH / 101:100uH)
- (4) Inductance Tolerance (K: ± 10% / M: ± 20% / N: ± 30%)
- (5) Lead Free Product

Shape & Dimensions

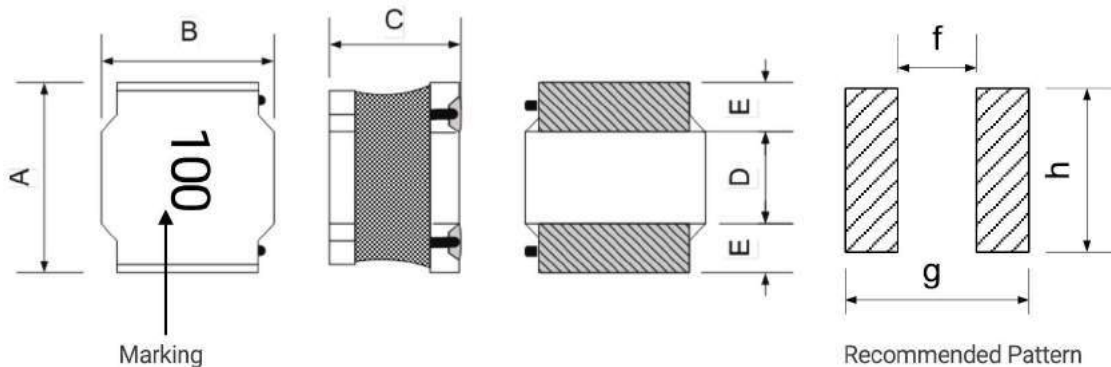

Dimensions (mm)							
A	B	C	D	E	f	g	h
6.0±0.30	6.0±0.30	4.5Max.	2.9±0.3	1.55±0.3	2.8 Typ.	6.2 Typ.	5.7 Typ.

Material List

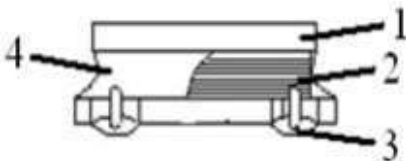

No.	Item	Material
1	Core	Ni-Zn Ferrite
2	Wire	Enameled Copper Wire
3	Terminal Electrode	Ag/Ni/Sn/Cu
4	Magnetic Glue	Epoxy resin and magnetic powder



Power Inductor Wire Wound(NR) Type

HPIT Series Ferrite 6045 Size

Electrical Characteristics

HPIT6045 Size

HONGDA Part No.	Inductance (uH)	DCR (Ω)		Isat (A)		Irms (A)	
		Max.	Typ.	Max.	Typ.	Max.	Typ.
HPIT6045-R82M-LF	0.82 \pm 20%	0.011	0.008	13.00	15.00	5.75	6.35
HPIT6045-1R0M-LF	1.0 \pm 20%	0.011	0.008	12.00	13.00	6.50	7.50
HPIT6045-1R2M-LF	1.2 \pm 20%	0.013	0.010	11.00	12.50	5.50	6.05
HPIT6045-1R5M-LF	1.5 \pm 20%	0.013	0.010	10.00	11.50	5.50	6.05
HPIT6045-1R8M-LF	1.8 \pm 20%	0.016	0.012	9.50	10.50	4.85	5.60
HPIT6045-2R2M-LF	2.2 \pm 20%	0.018	0.014	9.00	10.50	4.60	5.00
HPIT6045-3R0M-LF	3.0 \pm 20%	0.024	0.018	8.00	9.00	4.00	4.40
HPIT6045-3R3M-LF	3.3 \pm 20%	0.024	0.018	8.00	9.00	4.00	4.40
HPIT6045-3R9M-LF	3.9 \pm 20%	0.025	0.021	6.20	6.80	3.90	4.30
HPIT6045-4R7M-LF	4.7 \pm 20%	0.034	0.026	6.00	7.50	3.80	4.20
HPIT6045-6R8M-LF	6.8 \pm 20%	0.040	0.031	5.50	6.20	3.00	3.30
HPIT6045-8R2M-LF	8.2 \pm 20%	0.045	0.038	4.50	5.00	2.85	3.15
HPIT6045-100M-LF	10 \pm 20%	0.056	0.046	4.20	4.80	2.75	3.00
HPIT6045-120M-LF	12 \pm 20%	0.065	0.050	4.00	4.50	2.50	2.75
HPIT6045-150M-LF	15 \pm 20%	0.085	0.065	3.50	3.80	2.10	2.30
HPIT6045-220M-LF	22 \pm 20%	0.116	0.089	3.20	3.50	1.80	2.00
HPIT6045-330M-LF	33 \pm 20%	0.175	0.135	2.40	2.60	1.45	1.60
HPIT6045-470M-LF	47 \pm 20%	0.260	0.200	2.20	2.30	1.20	1.30
HPIT6045-560M-LF	56 \pm 20%	0.286	0.220	1.70	1.90	1.15	1.25
HPIT6045-680M-LF	68 \pm 20%	0.325	0.250	1.65	1.80	1.10	1.20
HPIT6045-820M-LF	82 \pm 20%	0.408	0.340	1.40	1.50	1.05	1.15
HPIT6045-101M-LF	100 \pm 20%	0.468	0.390	1.30	1.40	1.00	1.10
HPIT6045-121M-LF	120 \pm 20%	0.585	0.450	1.10	1.20	0.90	1.02
HPIT6045-151M-LF	150 \pm 20%	0.740	0.570	0.95	1.15	0.80	0.91
HPIT6045-221M-LF	220 \pm 20%	1.050	0.880	0.70	1.00	0.50	0.60
HPIT6045-331M-LF	330 \pm 20%	1.464	1.220	0.70	0.77	0.58	0.64
HPIT6045-471M-LF	470 \pm 20%	2.300	1.770	0.53	0.60	0.45	0.50
HPIT6045-102M-LF	1000 \pm 20%	5.650	4.700	0.40	0.45	0.30	0.35

Power Inductor Wire Wound(NR) Type

HPIT Series

Ferrite 8040/8065 Size



Ordering Information

HPIT 8040 - 1R0 M - LF

(1) (2) (3) (4) (5)

- (1) Series Name
- (2) Product Dimension (L*W mm)
- (3) Inductance Value (1R0:1.0uH / 100:10uH / 101:100uH)
- (4) Inductance Tolerance (K: ± 10% / M: ± 20% / N: ± 30%)
- (5) Lead Free Product

Shape & Dimensions

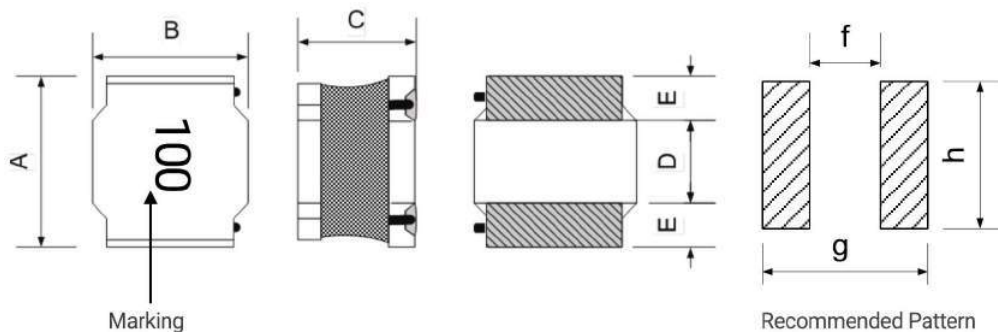

Size	Dimensions (mm)							
	A	B	C	D	E	f	g	h
8040	8.00±0.30	8.00±0.30	4.20Max.	3.80±0.3	2.10±0.3	3.80 Typ.	8.20 Typ.	7.50 Typ.
8065	8.00±0.30	8.00±0.30	6.50Max.	3.80±0.3	2.10±0.3	3.80 Typ.	8.20 Typ.	7.50 Typ.

Material List

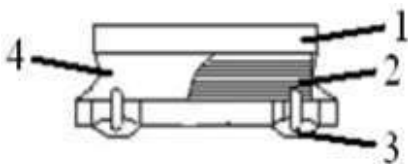

No.	Item	Material
1	Core	Ni-Zn Ferrite
2	Wire	Enameled Copper Wire
3	Terminal Electrode	Ag/Ni/Sn/Cu
4	Magnetic Glue	Epoxy resin and magnetic powder

HPIT8040 Size

HONGDAPart No.	Inductance (uH)	DCR (Ω)		Isat (A)	Irms (A)	SRF
		Max.	Typ.	Max.	Max.	(MHz)
HPIT8040-R47N-LF	0.47 \pm 30%	0.007	0.005	16.50	8.00	110.00
HPIT8040-R68N-LF	0.68 \pm 30%	0.007	0.005	15.50	8.00	104.00
HPIT8040-R82M-LF	0.82 \pm 20%	0.008	0.006	15.20	7.80	95.00
HPIT8040-R90M-LF	0.90 \pm 20%	0.008	0.006	11.00	7.80	92.00
HPIT8040-1R0M-LF	1.0 \pm 20%	0.008	0.006	12.00	7.80	90.00
HPIT8040-1R4M-LF	1.4 \pm 20%	0.009	0.007	9.00	7.00	68.00
HPIT8040-1R5M-LF	1.5 \pm 20%	0.010	0.008	10.00	7.00	67.00
HPIT8040-1R8M-LF	1.8 \pm 20%	0.012	0.009	9.50	6.30	48.00
HPIT8040-2R0M-LF	2.0 \pm 20%	0.012	0.009	9.25	6.30	42.00
HPIT8040-2R2M-LF	2.2 \pm 20%	0.016	0.012	8.30	5.15	41.00
HPIT8040-3R0M-LF	3.0 \pm 20%	0.018	0.014	7.10	4.95	30.00
HPIT8040-3R3M-LF	3.3 \pm 20%	0.020	0.015	7.52	4.90	28.00
HPIT8040-3R6M-LF	3.6 \pm 20%	0.020	0.015	7.52	4.90	30.00
HPIT8040-3R9M-LF	3.9 \pm 20%	0.022	0.017	6.30	4.35	26.00
HPIT8040-4R7M-LF	4.7 \pm 20%	0.023	0.018	6.00	4.10	23.00
HPIT8040-5R1M-LF	5.1 \pm 20%	0.025	0.019	6.00	4.10	23.00
HPIT8040-5R6M-LF	5.6 \pm 20%	0.027	0.021	6.00	3.85	24.00
HPIT8040-6R2M-LF	6.2 \pm 20%	0.027	0.021	5.10	3.85	20.00
HPIT8040-6R8M-LF	6.8 \pm 20%	0.031	0.024	4.95	3.70	20.00
HPIT8040-8R2M-LF	8.2 \pm 20%	0.034	0.026	4.30	3.45	17.00
HPIT8040-100M-LF	10 \pm 20%	0.038	0.029	4.30	3.30	15.00
HPIT8040-120M-LF	12 \pm 20%	0.053	0.041	3.55	2.85	12.00
HPIT8040-150M-LF	15 \pm 20%	0.061	0.047	3.25	2.60	12.00
HPIT8040-180M-LF	18 \pm 20%	0.068	0.052	3.10	2.45	11.00
HPIT8040-220M-LF	22 \pm 20%	0.086	0.066	2.80	2.20	9.50
HPIT8040-270M-LF	27 \pm 20%	0.101	0.078	2.60	2.00	9.00
HPIT8040-330M-LF	33 \pm 20%	0.125	0.096	2.20	1.80	8.00
HPIT8040-360M-LF	36 \pm 20%	0.133	0.102	2.10	1.75	7.80
HPIT8040-390M-LF	39 \pm 20%	0.133	0.102	2.10	1.75	7.80
HPIT8040-430M-LF	43 \pm 20%	0.147	0.113	1.90	1.65	7.50
HPIT8040-470M-LF	47 \pm 20%	0.177	0.136	1.80	1.55	6.50
HPIT8040-510M-LF	51 \pm 20%	0.185	0.142	1.70	1.50	6.40
HPIT8040-560M-LF	56 \pm 20%	0.192	0.148	1.65	1.45	6.40
HPIT8040-620M-LF	62 \pm 20%	0.237	0.182	1.55	1.30	6.30
HPIT8040-680M-LF	68 \pm 20%	0.252	0.194	1.50	1.25	5.00
HPIT8040-750M-LF	75 \pm 20%	0.274	0.211	1.40	1.20	4.90
HPIT8040-820M-LF	82 \pm 20%	0.293	0.225	1.30	1.15	5.70
HPIT8040-910M-LF	91 \pm 20%	0.354	0.272	1.20	1.05	5.00
HPIT8040-101M-LF	100 \pm 20%	0.377	0.290	1.20	1.00	4.20
HPIT8040-121M-LF	120 \pm 20%	0.428	0.329	1.15	0.95	3.50
HPIT8040-151M-LF	150 \pm 20%	0.533	0.410	1.10	0.85	3.50
HPIT8040-221M-LF	220 \pm 20%	0.702	0.540	0.85	0.80	3.50
HPIT8040-331M-LF	330 \pm 20%	1.066	0.820	0.70	0.65	2.80
HPIT8040-681M-LF	680 \pm 20%	2.65	2.0	0.48	0.4	1.7

Power Inductor Wire Wound(NR) Type HPIT Series Ferrite 8065 Size

Electrical Characteristics

HPIT8065 Size

HONGDA Part No.	Inductance (uH)	DCR (Ω)		Isat (A)		Irms (A)	
		Max.	Typ.	Max.	Typ.	Max.	Typ.
HPIT8065-1R0M-LF	1.0 \pm 20%	0.011	0.008	20.00	22.00	7.30	8.00
HPIT8065-2R2M-LF	2.2 \pm 20%	0.016	0.013	15.00	18.00	6.30	7.00
HPIT8065-3R3M-LF	3.3 \pm 20%	0.018	0.015	9.70	10.50	5.20	6.00
HPIT8065-4R7M-LF	4.7 \pm 20%	0.022	0.018	8.50	9.50	5.00	5.70
HPIT8065-5R6M-LF	5.6 \pm 20%	0.026	0.022	8.50	9.50	4.60	5.50
HPIT8065-6R8M-LF	6.8 \pm 20%	0.028	0.024	7.50	8.30	4.50	5.10
HPIT8065-8R2M-LF	8.2 \pm 20%	0.031	0.026	7.00	8.00	4.40	4.80
HPIT8065-100M-LF	10 \pm 20%	0.043	0.036	6.50	7.50	3.50	4.00
HPIT8065-220M-LF	22 \pm 20%	0.065	0.054	4.50	5.00	2.90	3.30
HPIT8065-470M-LF	47 \pm 20%	0.144	0.120	3.00	3.50	2.05	2.30
HPIT8065-500M-LF	50 \pm 20%	0.132	0.110	3.00	3.50	2.10	2.30
HPIT8065-700M-LF	70 \pm 20%	0.180	0.150	2.50	2.80	1.80	2.00
HPIT8065-101M-LF	100 \pm 20%	0.280	0.233	2.10	2.50	1.35	1.50
HPIT8065-151M-LF	150 \pm 20%	0.430	0.350	1.70	2.00	1.00	1.15
HPIT8065-201M-LF	200 \pm 20%	0.640	0.533	1.65	1.80	0.95	1.00
HPIT8065-221M-LF	220 \pm 20%	0.649	0.541	1.40	1.60	0.90	0.95
HPIT8065-301M-LF	300 \pm 20%	0.818	0.682	1.30	1.50	0.85	0.90
HPIT8065-331M-LF	330 \pm 20%	0.840	0.700	1.10	1.30	0.80	0.90
HPIT8065-431M-LF	430 \pm 20%	1.200	1.000	1.00	1.15	0.65	0.70
HPIT8065-471M-LF	470 \pm 20%	1.500	1.250	1.00	1.20	0.60	0.68
HPIT8065-501M-LF	500 \pm 20%	1.550	1.290	1.00	1.10	0.60	0.65
HPIT8065-801M-LF	800 \pm 20%	2.400	2.000	0.80	0.90	0.55	0.60
HPIT8065-102M-LF	1000 \pm 20%	2.820	2.350	0.70	0.76	0.45	0.50
HPIT8065-152M-LF	1500 \pm 20%	4.380	3.650	0.54	0.61	0.35	0.38
HPIT8065-202M-LF	2000 \pm 20%	5.800	4.800	0.50	0.55	0.30	0.33
HPIT8065-222M-LF	2200 \pm 20%	6.000	5.000	0.45	0.51	0.27	0.31
HPIT8065-332M-LF	3300 \pm 20%	8.760	7.300	0.37	0.41	0.23	0.26
HPIT8065-472M-LF	4700 \pm 20%	14.520	12.150	0.32	0.35	0.19	0.21
HPIT8065-682M-LF	6800 \pm 20%	22.200	18.500	0.28	0.31	0.15	0.17

1 Test instruments and remarks

CHROMA 3302 meter for L and DCR.
 CHROMA 3302 and 1320meter for IDC.
 test condition: 100KHz/1V.

Isat:Based on inductance change ($|L_1-L|/L \leq 30\%$)

Irms:Based on temperature rise($\Delta T:40^\circ\text{C}$ TYP).

2 Condition of work

The part normal work be allowed ambient temperature: $-40^{\circ}\text{C} \sim +125^{\circ}\text{C}$.

3 Reliability and Test Condition

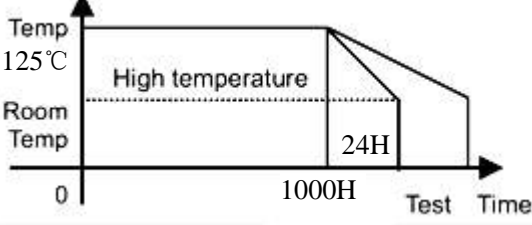
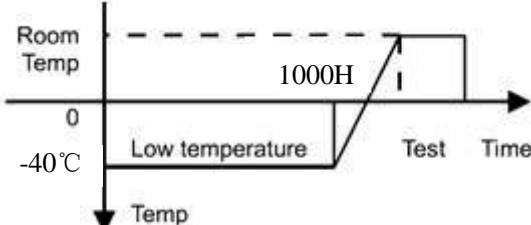
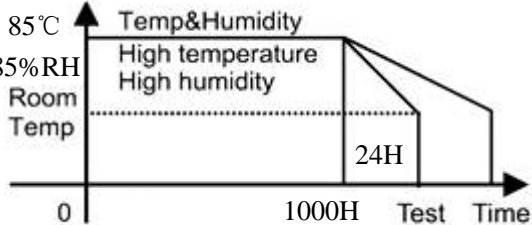
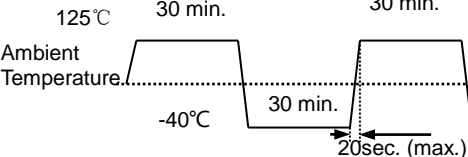
Item	Required Characteristics	Test Method/Condition
High temperature storage test	1. No case deformation or change in appearance. 2. $\Delta L/L \leq 10\%$	Temperature: $125 \pm 2^{\circ}\text{C}$ Time : 1000 hours Measurement at 24 ± 4 hours after test conclusion. 
Low temperature storage test		Temperature : $-40 \pm 2^{\circ}\text{C}$ Time : 1000 hours Measurement at 24 ± 4 hours after test conclusion. 
Humidity test		Temperature: $25-85^{\circ}\text{C}$, Humidity :85% RH Time : 1000 hours. Measurement at 24 ± 4 hours after test conclusion. 
Thermal shock test		First -40°C for 30min. time, last 125°C 30min. time as 1 cycle. Go through 1000 cycles. 

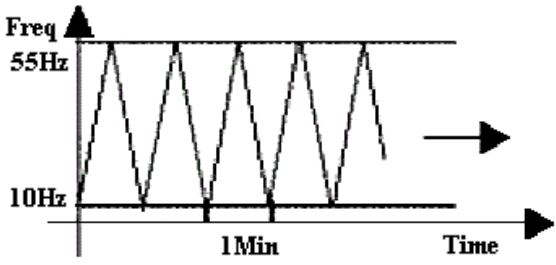
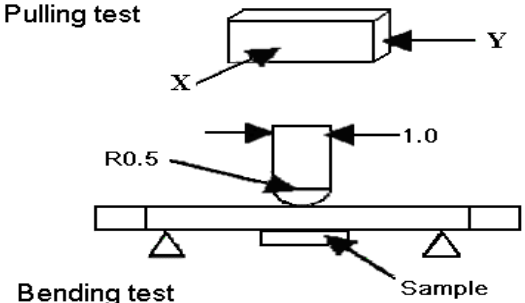
Item	Required Characteristics	Test Method/Condition
Solderability test	Terminal area must have 90% min. solder coverage.	Dip pads in flux then dip in solder pot at $245 \pm 5^\circ\text{C}$ for 5 ± 0.1 second. Solder: Sn96.5%、Ag3%、Cu0.5% Flux: rosin flux.
Heat endurance of reflow soldering		Refer to the next page reflow curve , Go through 3 times. The peak temperature: $260+5/-0^\circ\text{C}$
Vibration test	No case deformation or change in appearance. $\Delta L/L \leq 10\%$	Apply frequency 10~55Hz. 1.5mm amplitude in each of perpendicular direction for 2 hours in each 3 mutually perpendicular directions.(total 6 hours) 
Drop test		Drop 10 times on a concrete floor from a height of 1m.
Terminal strength push test	Pulling test: Solder the products on testing PCB using eutectic solder. Then apply a force in the direction of the arrow. 17.64N force. Keep time ≥ 10 s Bending test: Soldering the products on PCB, after the pulling test and bending test, terminal should not pull off.	Pulling test: The application of force X、 Y direction Bend the testing PCB at middle point, the deflection shall be 2mm. Pressurizing Speed: 0.5mm/sec, Keep time: 60 ± 1 s, 
Loading at High Temperature	1. No case deformation or change in appearance. 2. $ \Delta L/L \leq 10\%$	1. Temperature: $85 \pm 2^\circ\text{C}$ 2. Time : 1000 hours 3. Apply rated current 4. Measurement at 24 ± 4 hours after test conclusion

4 Recommended Soldering Conditions

Product can be applied to flow and reflow soldering.

[1] Flux, Solder

- ① Use rosin-based flux. Don't use highly acidic flux with halide content exceeding 0.2wt% (chlorine conversion value).
- ② Use Sn solder.

[2] Flow soldering conditions

- ① Pre-heating should be in such a way that the temperature difference between solder and product surface is limited to 150°C max. Cooling into solvent after soldering also should be in such a way that temperature difference is limited to 100°C max. Unwrought pre-heating may cause cracks on the product, resulting in the deterioration of products quality.

② Standard soldering profile.

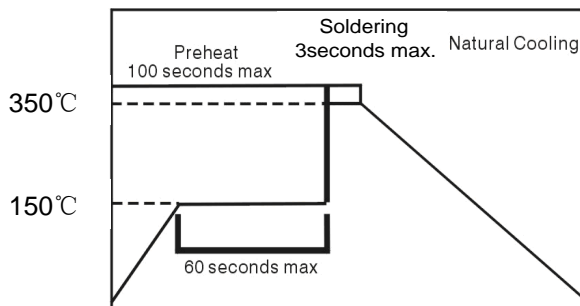

Pre-heating	150°C, 1 minute max.
Peak	350°C, 3 seconds max

[3] Reflow soldering conditions

Reflow curve

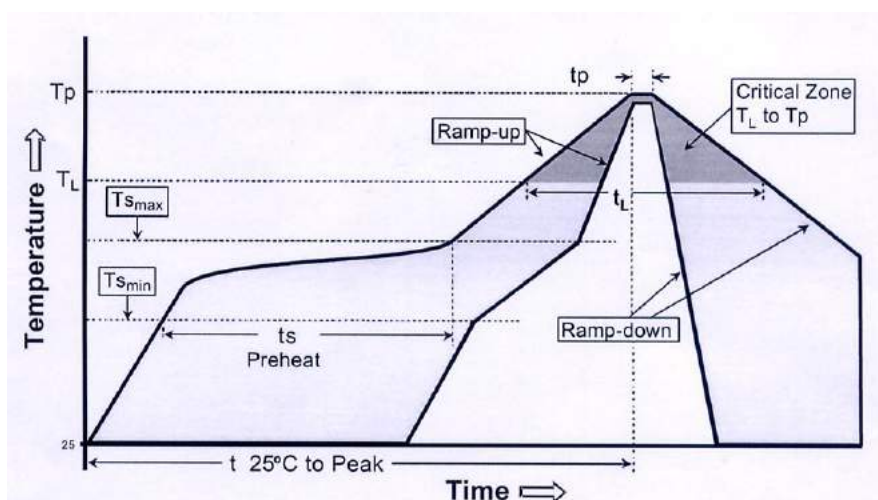

Profile Feature		Lead-Free Assembly
Average Ramp-Up Rate (Ts max. to Tp)		3°C/second max.
Preheat	Temperature Min (Ts min.)	150 °C
	Temperature Max (Ts max.)	200 °C
	Time (ts min to ts max.)	60-180 seconds
Time maintained above	Temperature (TL)	217 °C
	Time (tL)	60-150 seconds
Peak/Classification Temperature (Tp)		260 °C
Peak/Classification Time (Tp)		3-4 seconds
Time within 5 °C of actual Peak Temperature (Tp)		20-40 seconds
Ramp-Down Rate		6 °C/second max.
Time 25 °C to Peak Temperature		8 minutes max.

Note : All temperatures refer to topside of the package, measured on the package body surface.

[4] The method on Re-work with using the iron:

The following conditions must be strictly followed when using a soldering iron

Pre-heating	150°C, 1 minute
Tip temperature	350°C max
Soldering iron output	80w max
End of soldering iron	φ1mm max
Soldering time	3 seconds max

Product once removes from the circuit board may not be used again.

5. Package Information

5.1 Dimension of tape (Unit: mm)

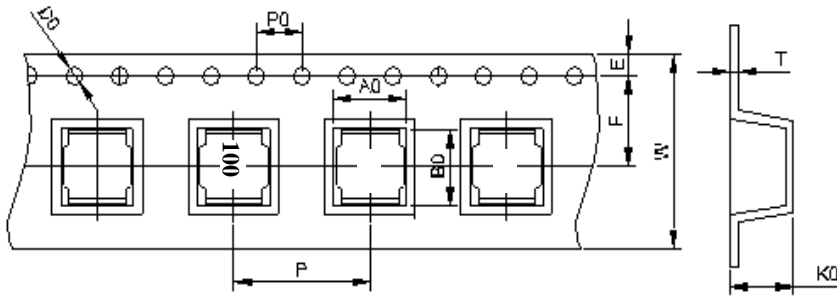

W	A0	B0	K0	E	F	P	P0	D0	T
12±0.3	5.4±0.1	5.4±0.1	4.4±0.1	1.75±0.1	5.5±0.1	8.0±0.1	4.0±0.1	1.5±0.1	0.40±0.05

5.2 Dimension of reel (Unit: mm)

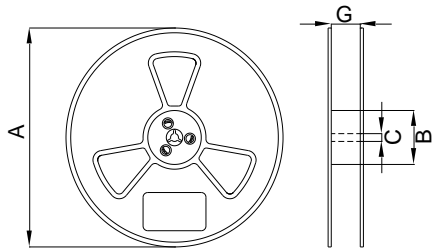

A	330±1
B	100±1
C	13±0.5
G	13±0.5

9.3 Taping figure and drawing direction

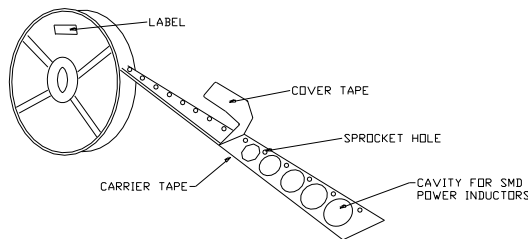

5.4 Packaging quantities: 1500PCS/Reel.

5.5 Peeling strength of cover tape:

The peel force of top cover tape shall be between 0.1N to 1.3N

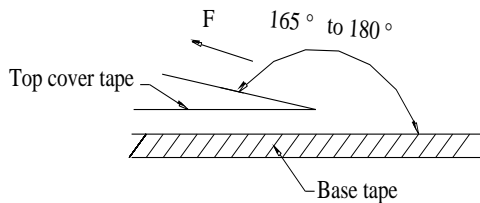

Room Temp. (°C)	Room Humidity (%)	Room aim (hpa)	Peel Speed Mm/min
5-35	45-85	860-1060	300

6 Visual inspection standard of product

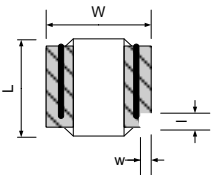
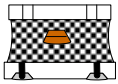
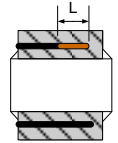
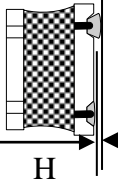
No.	Defect Item	Graphic	Rejection identification	Acceptance
1	Core defect		$l > L/6$ or $w > W/6$, NG.	AQL=0.65
2	Missing resin		The area of missing resin more than 1/3 single face, NG	AQL=0.65
3	Cold solder		L more than 1 mm, NG.	AQL=0.65
4	Solder uneven		$H > 0.1$ mm. NG.	AQL=0.65

7. Storage

(1) Storage period

Products which inspected in HONGDA over 12 months ago should be examined and used, which can be confirmed with inspection No. marked on the container. Solder ability should be checked if this period is exceeded.

(2) Storage conditions

① Products should be storage in the warehouse on the following conditions

Temperature: $-10^{\circ}\text{C} \sim 40^{\circ}\text{C}$

Humidity : $\leq 70\%$ relative humidity

No rapid change on temperature and humidity

- ② Don't keep products in corrosive gases such as sulfur, chlorine gas or acid, or it may cause oxidization of electrode, resulting in poor solder ability.
- ③ Products should be storage on the palette for the prevention of the influence from humidity, dust and so on.
- ④ Products should be storage in the warehouse without heat shock, vibration, direct sunlight and so on.
- ⑤ Products should be storage under the airtight packaged condition.