



1. Scope

This specification applies to the HD Radial inductors.

2. Product Identification

<u>HD</u>	<u>0406</u>	<u>470</u>	<u>K</u>	<u>B</u>	<u>-LF</u>
①	②	③	④	⑤	⑥

- ① Product Symbol(HD)
- ② Dimensions
- ③ Inductance Value (470: 47uH)
- ④ Inductance Tolerance(K:±10%)
- ⑤ Packaging Style(B:Bulk; A:Ammo)
- ⑥ Lead Free

CUSTOMER		DATE	2023/01/03
OUR PART NO	HD0406-470KB-LF	OUR PART NAME	Radial Inductor

Appearance of size

Unit: mm

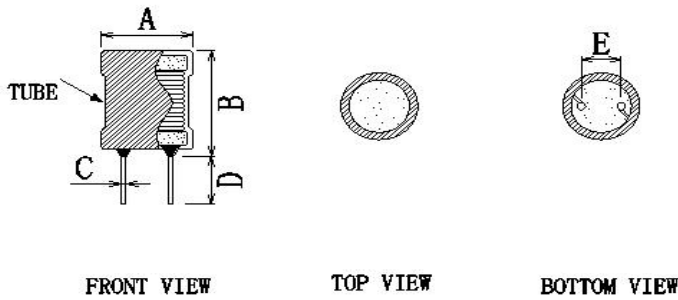

A	5.5 MAX	C	0.5±0.1	E	2.0±0.5		
B	9.0 MAX	D	15.0±2.0				
Identification							

Schematic Diagram

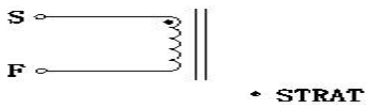

Winding Structure Diagram

WINDING	S	F	WIRE	TURNS	WINDINGWA		
N1	S	F	2UEW-0.20mm	48.5TS	Flat-wise coil		

Matters needing attention:



CUSTOMER		DATE	2023/01/03
OUR PART NO	HD0406-470KB-LF	OUR PART NAME	Radial Inductor
Electrical parameters			
TEST PROJECT	SPEC	TEST FREQ	TEST STRUMENTS
L	47uH±10%	at 25°C 1KHz/0.25V	TH2829A
DCR	0.5Ω MAX	at 25°C 1KHz/0.25V	HK-100
Isat	L ≥ L0*90%	at 25°C DC500mA 1KHz/0.3V	TH1772B
BOM			
MATERIAL	SPECIFICATIONS	MANUFACTURERS	UL FILE NO
CORE	MgZn DR2W4*6	HUAZHONG	
		OR Equivalent supplier	
WIRE	2UEW-F(QA)	GANYUE HENGXING	E233255
		OR Equivalent supplier	
PIN	Tinned copper clad steel wire	BAICHUAN	
		OR Equivalent supplier	
TUBE	UL HEAT-SHRINKABLE TUBE/125°C	XINGQI	E350991
		OR Equivalent supplier	
EPOXY RESIN	FK661	QI FU	
		OR Equivalent supplier	
SOLDER	Sn:99.3%/Cu:0.7%	SONGBEN	
		OR Equivalent supplier	

Matters needing attention

- 1、 Our products are designed and promoted for use in general electronic devices such as audio-video equipment, office automation equipment, home appliance and information service.
- 2、 In case of using the product for the purpose other than general electronics devices, we shall not be held liable for any dysfunctions in or damage to the equipment with which the product is used.
- 3、 Our specification limits the quality of the component as a single unit. Please ensure the component is thoroughly evaluated in your application circuit.
- 4、 Do not apply excessive vibration or mechanical shock to products.
- 5、 Do not touch wire with sharp objects such as tweezers to prevent wire breakage.
- 6、 Do not apply excessive stress to products mounted on boards to prevent core breakage.
- 7、 To maintain the solderability of terminal electrodes and to keep the packing material in good condition, product should be used within 6 months from the time of delivery. And the solderability of products electrodes may decrease as time passes, so in case of storage over 6 months, solderability shall be checked before actual usage.
- 8、 Store products in a warehouse in compliance with the following condition:

Conditions	Packing status	Component itself
Temperature	-25~+40℃	-25~+85℃
Humidity	30~70%RH	30~70%RH

- 9、 Do not subject products to rapid changes in temperature and humidity.
- 10、 Do not store the products in chemical atmosphere such as one containing sulfurous acid gas or alkaline gas, that will causes poor solderability and corrosion of inductors.
- 11、 Store products on pallets to protect from humidity, dust, etc
- 12、 Avoid heat shock, vibration, direct sunlight, etc.