

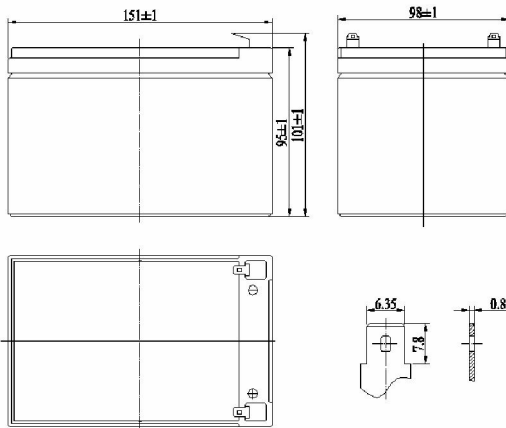

FL12120

(12V12.0Ah/20hr)



General Series

General Series Valve Regulated Lead Acid batteries are designed with AGM (Absorbent Glass Mat) technology, high performance plates and electrolyte to gain extra power output for common power backup system applications widely used in the field of UPS, Emergency Lighting System.

Application

- Alarm System
- Cable Television
- Power tools
- Emergency Power System
- Security System
- Medical Equipment
- UPS
- Communication Equipment
- Control Equipment
- Toys

General Features

- Sealed and maintenance free operation.
- Non-Spillable construction design.
- ABS containers and covers(UL94HB, UL94V-0) optional.
- Safety valve installation for explosion proof .
- High quality and high reliability.
- Exceptional deep discharge recovery performance.
- Low self discharge characteristic.
- Flexibility design for multiple install positions.

CONSTRUCTION

| Component | Positive plate | Negative plate | Container | Cover | Safety valve | Terminal | Separator | Electrolyte |
|--------------|----------------|----------------|-----------|-------|--------------|----------|------------|---------------|
| Raw material | Lead dioxide | Lead | ABS | ABS | Rubber | Copper | Fiberglass | Sulfuric acid |

TECHNOLOGY PARAMETER

| Battery model | FL12120 | | | |
|-------------------------------------|---|--------------------|---------------------|-------------------|
| Designed Floating Life | 3~5 Years | | | |
| Capacity (25) | 20hR(0.6A, 10.5V) | 10hR(1.14A, 10.5V) | 5hR(2.06A, 10.5V) | 1hR(8.09A, 9.60V) |
| | 12.0Ah | 1.14Ah | 10.3Ah | 8.09Ah |
| Dimensions | Length | Width | Height | Total Height |
| | 151±1mm | 98±1mm | 95±1mm | 101±1mm |
| Approx. weight (±5%) | 3.65 Kg (8.05 lbs) | | | |
| Internal resistance | Full charged at 25 : Approx. 18mOhms | | | |
| Self discharge | 3% of capacity declined per month at 25 (average) | | | |
| Capacity Affected by Temp.(20HR) | 40 | 25 | 0 | -15 |
| | 102% | 100% | 85% | 65% |
| Charge Voltage (25) | Cycle use | | Float use | |
| | 14.5-14.9V(-30mV/), max. Current: 3.6A | | 13.6-13.8V(-20mV/) | |



FL12120 (12V12.0Ah/20hr)

Constant current discharge ratings-amperes at 25

| End Point Volts/Cell | 5min | 10min | 15min | 30min | 1h | 3h | 5h | 10h | 20h |
|-------------------------|------|-------|-------|-------|------|------|------|------|-------|
| 1.60V | 46.3 | 32.6 | 24.9 | 13.8 | 8.09 | 3.40 | 2.15 | 1.22 | 0.621 |
| 1.65V | 44.5 | 31.4 | 24.2 | 13.3 | 7.70 | 3.29 | 2.12 | 1.19 | 0.616 |
| 1.70V | 41.9 | 30.2 | 23.6 | 12.8 | 7.33 | 3.18 | 2.09 | 1.16 | 0.608 |
| 1.75V | 39.3 | 29.0 | 22.7 | 12.3 | 6.96 | 3.05 | 2.06 | 1.14 | 0.600 |
| 1.80V | 36.8 | 27.8 | 22.0 | 11.8 | 6.81 | 2.91 | 2.02 | 1.11 | 0.589 |

Constant power discharge ratings-watts at 25

| End Point Volts/Cell | 5min | 10min | 15min | 30min | 1h | 3h | 5h | 10h | 20h |
|-------------------------|------|-------|-------|-------|------|------|------|------|------|
| 1.60V | 85.7 | 60.4 | 46.4 | 25.8 | 15.2 | 6.43 | 4.08 | 2.32 | 1.19 |
| 1.65V | 81.8 | 57.8 | 44.8 | 24.7 | 14.4 | 6.19 | 4.00 | 2.26 | 1.18 |
| 1.70V | 76.7 | 55.3 | 43.5 | 23.6 | 13.6 | 5.95 | 3.92 | 2.20 | 1.16 |
| 1.75V | 71.6 | 52.8 | 41.6 | 22.6 | 12.9 | 5.67 | 3.85 | 2.14 | 1.13 |
| 1.80V | 66.2 | 50.0 | 39.8 | 21.4 | 12.5 | 5.35 | 3.74 | 2.07 | 1.10 |

