

*Product information on FIC00460 for CO detector using TGS2442*

**Contents:**

- 1. Features**
- 2. Construction of microcomputer**
- 3. Pin assignment/ Functions**
- 4. An example of application circuit**
- 5. Parts list for application circuit**
- 6. Specification of CO detector**

*Appendix A: Operational sequence - Gas detection mode*

*Appendix B: Operational sequence - Gas calibration mode*

*Appendix C: Flow chart/ Calculating delay time for alarming*

*Appendix D: Sensor operation and signal processing*

## ***Features***

- \*High reliable computer control for sensor operation and signal processing***
- \* Design for a low number of external electric components to connect***
- \* 3 levels indication in accordance with CO concentration***
- \* Audible alarm on time-weighted averaging of CO concentration***
- \* Option for mono-color or tri-color LED drive***
- \* Option for external-drive or self-drive buzzer***
- \* Function for self-diagnostic circuit***
- \* Buzzer Test/ Mute function***
- \* Fuction for external output and input***
- \* Watchdog timer***
- \* Simplified gas calibration mode***
- \* Conform to standard UL2034***

## Construction of microcomputer

CPU core type:

\* C-MOS 4 bit single chip MCU (8MHZ)

Specification:

\* 4K-Byte ROM, 256-Nibble RAM

\* Minimum command time; 1.0  $\mu$ s

\* 8-bit A/D converter; 24  $\mu$ s at 8MHz

\* High current output port; typ. 20mA

\* Pulse output port for direct BZ drive

\* Internal watchdog timer

\* Package; SDIP 28 pin

Dimensions:

Unit: mm

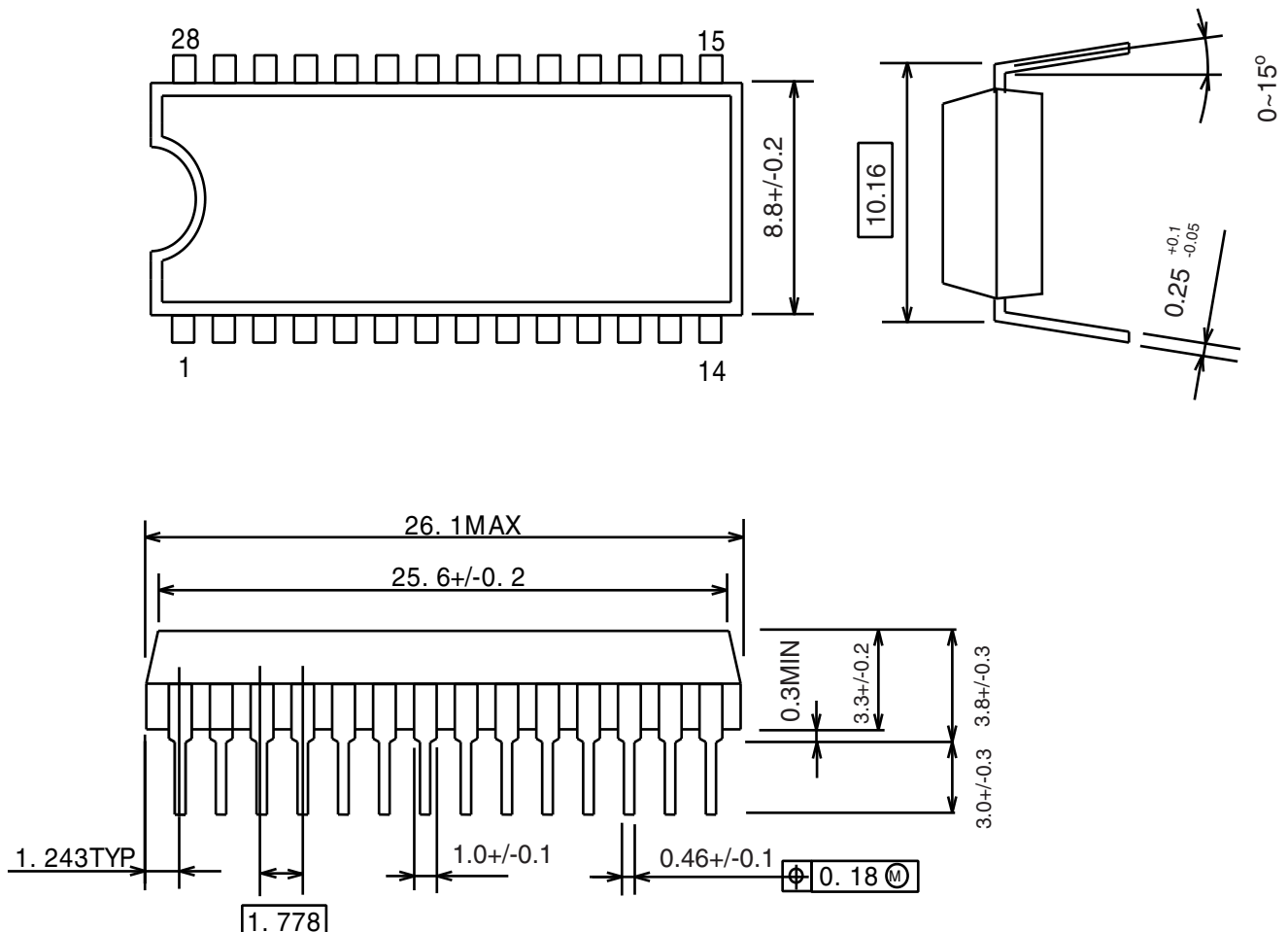

## Pin assignment/ Functions

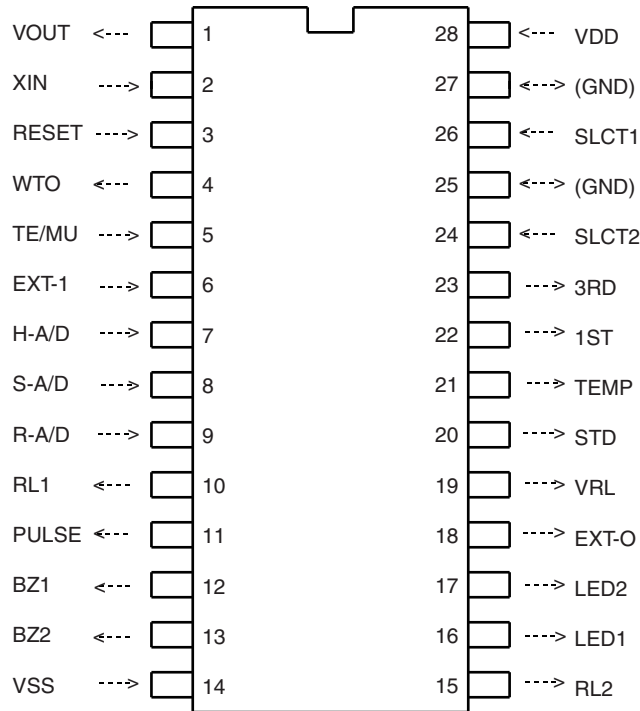

Pin name	Pin No.	I/O	Fuction
VDD	28	(Power)	+5V
VSS	14	(Power)	GND
XOUT	01	OUT	For ceramic resonator (8MHz)
XIN	02	IN	For ceramic resonator (8MHz)
RESET	03	IN	Reset
WTO	04	OUT	Watchdog timer output
SLCT1	26	IN	For selecting LED drive mode
SLCT2	24	IN	For selecting buzzer drive mode
H-A/D	07	A/D	Heater voltage input
S-A/D	08	A/D	Sensor voltage input
R-A/D	09	A/D	Reference voltage input
PULSE	11	OUT	For heater pulse control
RL1	10	OUT	Switching load resistance for sensor signal sampling
RL2	15	OUT	Switching load resistance for sensor trouble detection
STD	20	OUT	Switching reference voltage for base (2ND) alarm level
TEMP	21	OUT	Switching reference voltage for temperature compensation
1ST	22	OUT	Switching reference voltage for 1ST alarm level
3RD	23	OUT	Switching reference voltage for 3RD alarm level
LED1	16	OUT	For LED drive
LED2	17	OUT	For LED drive
BZ1	12	OUT	For buzzer drive
BZ2	13	OUT	For buzzer drive
EXT-I	06	IN	For external input signal
EXT-O	18	OUT	For external output signal
TE/MU	05	IN	Buzzer test/ mute signal input
VRL	19	OUT	Modulating sensor signal
-	25	-	(Connect to GND)
-	27	-	(Connect to GND)

## An example of application circuit

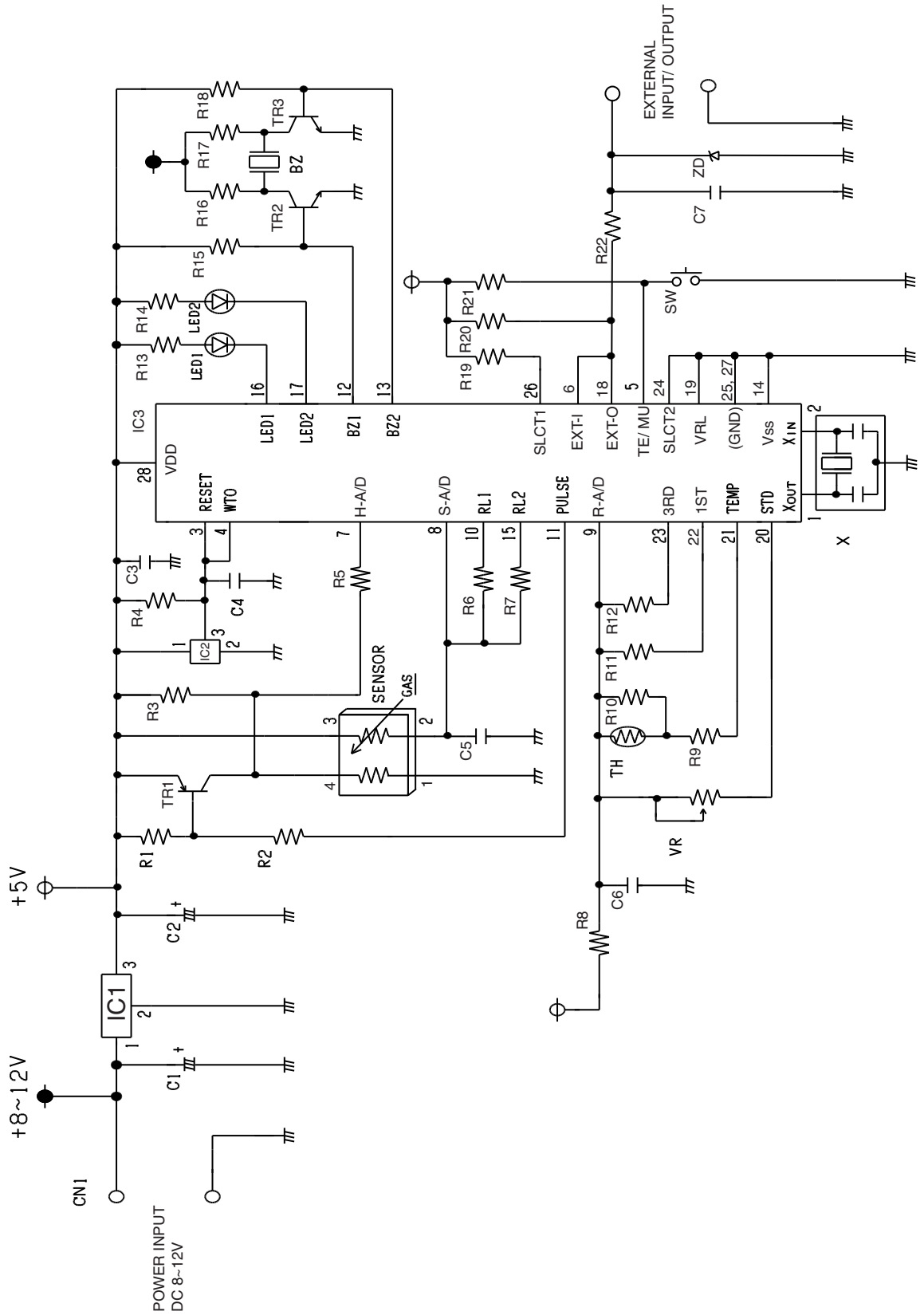

## **Parts list for application circuit**

S-No.	Part Name	Model No./ Specification	Maker	Remarks
SENSOR	Gas sensor	TGS2442	Figaro	
IC1	Voltage regulator	TA78M05	Toshiba	
IC2	Reset IC	PST591G Vreset=3.3V	Mitsumi	
IC3	Microcomputer	TMP47P443VN(OTP) Software ver. FP01C-01	Toshiba Figaro	
R1	Carbon resistor	10k , 5%, 1/4W		
R2	Carbon resistor	300 , 5%, 1/4W		
R3	Carbon resistor	20k , 5%, 1/4W		
R4	Carbon resistor	10k , 5%, 1/4W		
R5	Carbon resistor	1k , 5%, 1/4W		
R6	Carbon resistor	33k , 5%, 1/4W		RL for gas detection
R7	Carbon resistor	200k , 5%, 1/4W		RL for self-diagnosis
R8	Carbon resistor	20k , 5%, 1/4W		
R9	Carbon resistor	3k , 5%, 1/4W		Temp. compensation
R10	Carbon resistor	(no connection)		Temp. compensation
R11	Carbon resistor	27k , 5%, 1/4W		1ST level sensitivity
R12	Carbon resistor	18k , 5%, 1/4W		3RD level sensitivity
R13	Carbon resistor	300k , 5%, 1/4W		
R14	Carbon resistor	1k , 5%, 1/4W		
R15	Carbon resistor	10k , 5%, 1/4W		
R16	Carbon resistor	1k , 5%, 1/4W		
R17	Carbon resistor	1k , 5%, 1/4W		
R18	Carbon resistor	10k , 5%, 1/4W		
R19	Carbon resistor	10k , 5%, 1/4W		
R20	Carbon resistor	10k , 5%, 1/4W		
R21	Carbon resistor	10k , 5%, 1/4W		
R22	Carbon resistor	300k , 5%, 1/4W		
C1	Electrolytic capacitor	100 F/25V		
C2	Electrolytic capacitor	10 F/16V		
C3	Ceramic capacitor	104/16V		
C4	Ceramic capacitor	104/16V		
C5	Ceramic capacitor	103/16V		
C6	Ceramic capacitor	104/16V		
C7	Ceramic capacitor	104/16V		
TH	NTC Thermistor	R(25°C)=10k , Bconst.=3400		Temp. compensation
VR	Variable resistor	100k , 1/5W		2ND level sensitivity
TR1	PNP Transistor	2SB1116	NEC	
TR2	NPN Transistor	2SC2603	Mitsubishi	
TR3	NPN Transistor	2SC2603	Mitsubishi	
LED1	Light emitting diode	Diffused green color, 5		
LED2	Light emitting diode	Diffused red color, 5		
BZ	Piezoelectric buzzer	EFBRD22C415	Panasonic	
SW	Switch	Tactile switch		
ZD	Zener diode	RD10FM	NEC	
X	Ceramic resonator	CST8.00MTW	Murata	

## **Specification of CO detector using TGS2442**

Sensor		TGS2442	
Target gas		Carbon monoxide	
Detecting interval		1 sec/ cycle	
Alarm points	Visual alarm (Warning)	First level	30~70ppm CO (typ. 45ppm CO)
		Second level	70~150ppm CO (typ. 100ppm CO)
		Third level	150~400ppm CO (typ. 245ppm CO)
	Audible alarm	Below 10% COHb calculated time-weight average (refer to Appendix C)	
Alarm indication	Visual alarm (Warning)	First level	Red LED blink once per second
		Second level	Red LED blink twice per second
		Third level	Red LED blink continuously
	Audible alarm	85 dB at 3m, Intermittent	
Power indication		Green LED	
Malfunction		Green LED and red LED blink with audible alarm	
Buzzer test/mute		Test	Red LED blink with audible alarm
		Mute	Silencing alarm and external output for 3min.
External output signal		Normal and warning: 5V, Audible alarm: 0V	
Optional function		Gas calibration mode (refer to Appendix B)	
Power source		DC 8~12V	
Power consumption		Below 0.3W	
Operating condition		0-52°C (below 95% R.H.)	
Reference condition		Conform to UL2034	

**Note:**

*Refer to appendix A for operational sequence of LED, buzzer and external output.  
Refer to appendix D for determination of warning level.*



## Appendix B. Operational sequence/ Gas calibration mode

- Step 1: Turn the volume (VR1) right to the minimum resistance.
- Step 2: Place detector in the chamber and power on.
- Step 3: 100ppm CO gas injection.
- Step 4: Wait for 10 minutes.
- Step 5: Reset into calibration mode by power off-on.
- Step 6: CO gas ventilation
- Step 7: Adjust VR1 to left direction slowly. When both G-LED and R-LED light at the same time, calibration is performed.
- Step 8: Reset the power supply again. -> Shift into gas detection mode [  $V_{ref} \geq 0.5V$  ]

Note) Before calibration, the detector should be powered for a certain period for sensor aging.

Function: At the change of indication microcomputer memorizes a calibration level (2nd. threshold) through the sensor output.

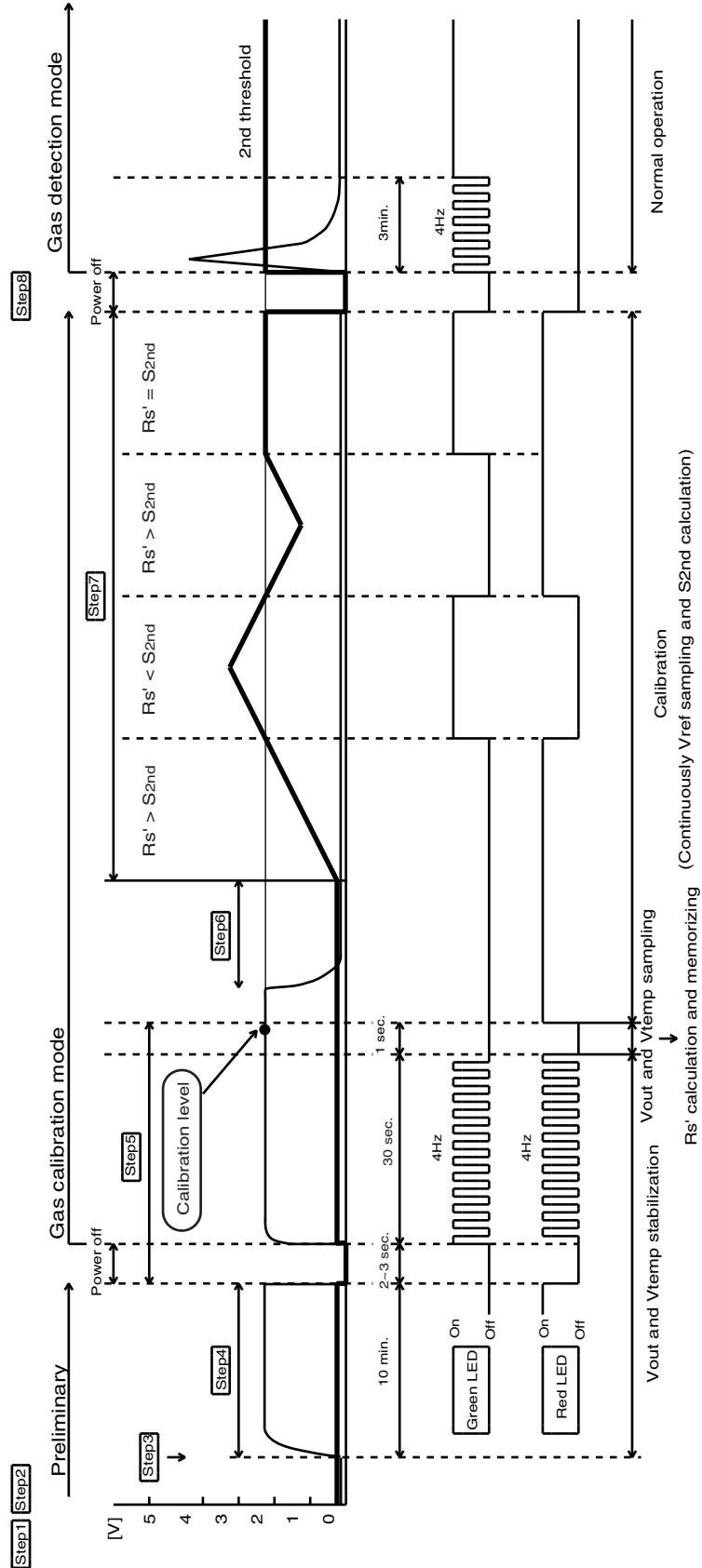

# Appendix C. Flowchart/ Calculating delay time for alarming

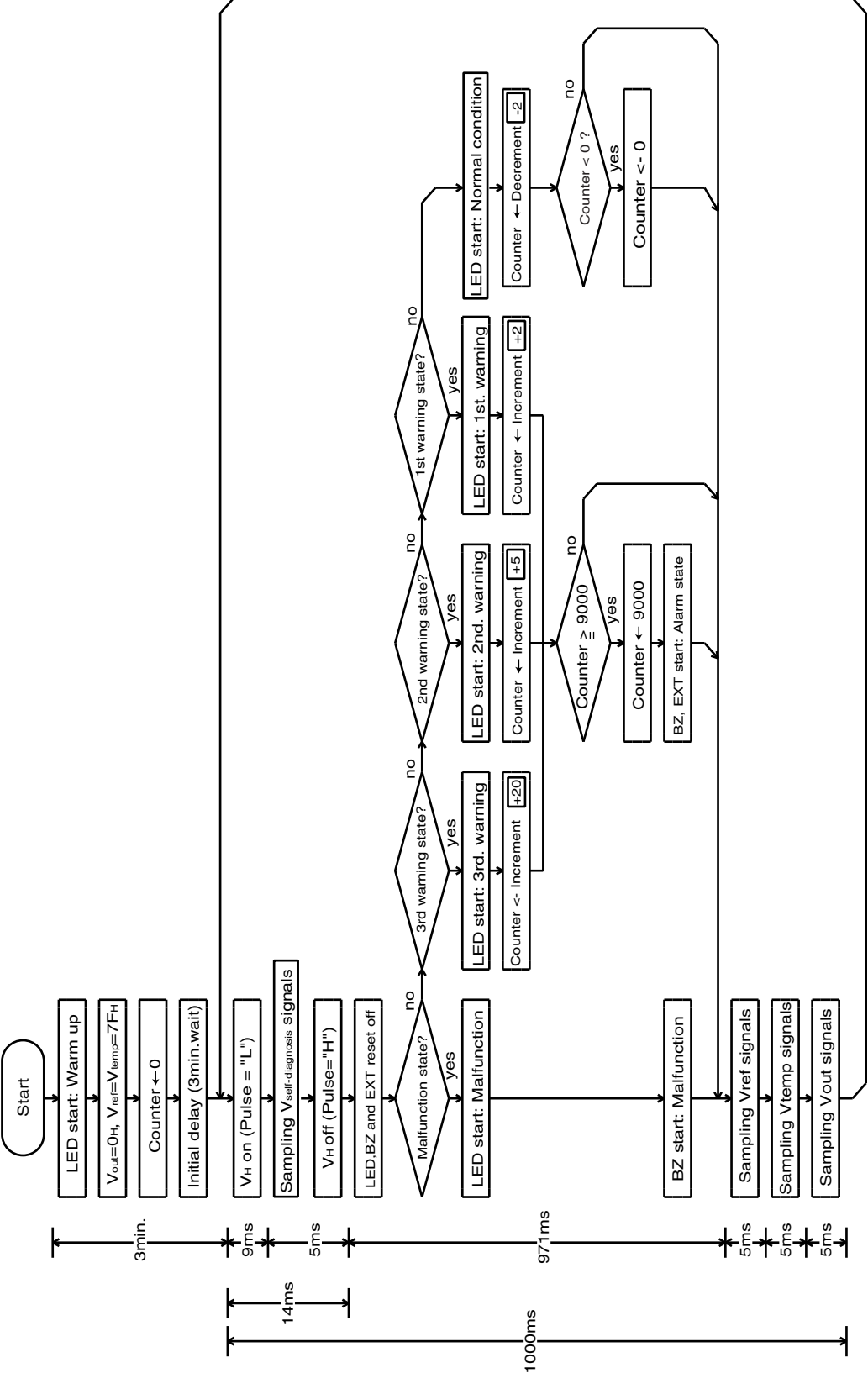

## Appendix D. Signal processing by microcomputing

### Procedure of signal processing

1) Calculation of sensor resistance ( $R_s$ ):

$$R_s \leftarrow \frac{5 - V_{out}}{V_{out}}$$

2) Calculation of a coefficient for temperature compensation ( $K_{temp}$ ):

$$K_{temp} \leftarrow \frac{5 - V_{temp}}{V_{temp}}$$

3) Sensor resistance with temperature compensation ( $R_s'$ ):

$$R_s' \leftarrow R_s \times K_{temp}$$

4) Calculation of 2nd. threshold ( $S_{2nd}$ ):

$$S_{2nd} \leftarrow \frac{5 - V_{ref}}{V_{ref}}$$

5) Calculation of 1st. and 3rd. threshold ( $S_{1st}$ ,  $S_{3rd}$ ):

$$S_{1st} \leftarrow S_{2nd} \times 1.74$$

$$S_{3rd} \leftarrow S_{2nd} \times 0.474$$

6) Determination of gas detecting state:

Detecting state	Determinate condition
Normal	$R_s' > S_{1st}$
1st warning	$S_{1st} \leq R_s' < S_{2nd}$
2nd warning	$S_{2nd} \leq R_s' < S_{3rd}$
3rd warning	$R_s' \leq S_{3rd}$

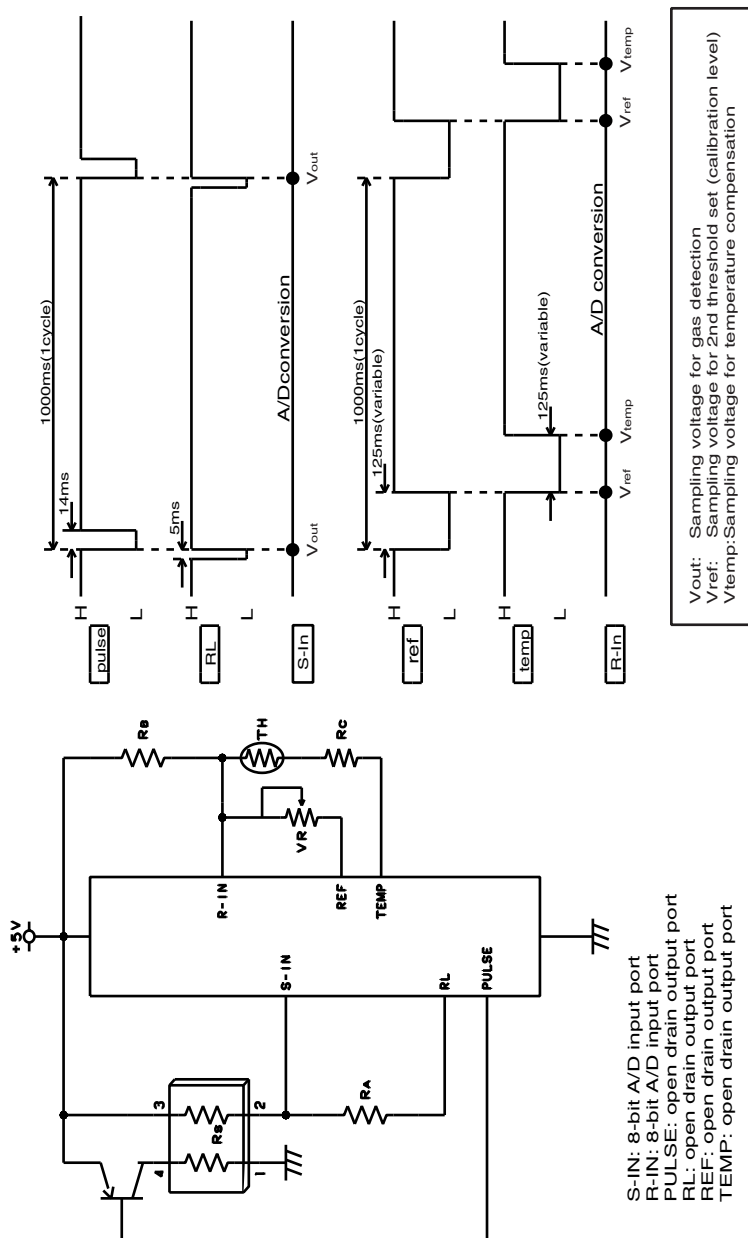

Basic circuit and timing chart

REV: 12/03

**FIGARO ENGINEERING INC.**

1-5-11 Senba-nishi  
Mino, Osaka 562-8505 JAPAN  
Phone: (81)-727-28-2561  
Fax: (81)-727-28-0467  
email: [figaro@figaro.co.jp](mailto:figaro@figaro.co.jp)