

**FIGARO**

an ISO9001 and 14001 company

**Technical Information for the CDM4161 CO2 Module**

CDM4161 is a new unit which uses TGS4161, Figaro's low-power consumption solid electrolyte CO2 sensor. Due to Figaro's proprietary idea for signal processing with a microcomputer, no maintenance is required for this module. When compared with traditional CO2 sensor modules using IR sensors, Figaro's CO2 module is much more cost effective, making this module the ideal choice for indoor air quality control systems.



	<i>Page</i>
<i>Basic Information and Specifications</i>	
Features.....	2
Applications.....	2
Specifications.....	2
Dimensions.....	2
<i>Structure and functions</i>	
Solid electrolyte CO2 sensor TGS4161.....	2
Sensor's output signal voltage (CP4).....	2
Thermistor signal output voltage (CP3).....	2
Microcomputer.....	2
Concentration setting for system control (JP1, JP2).....	2
Baseline reset switch.....	2
Input-output signal (CN1).....	4
LEDs.....	4
<i>Operation modes</i>	
Warm up.....	5
CO2 concentration lower than calibrated concentration.....	5
CO2 concetration exceeds calibrated concentration.....	5
Trouble.....	5
<i>Cautions</i> .....	5
<i>Important Notice</i> .....	6

**IMPORTANT NOTE:** OPERATING CONDITIONS IN WHICH FIGARO SENSORS ARE USED WILL VARY WITH EACH CUSTOMER'S SPECIFIC APPLICATIONS. FIGARO STRONGLY RECOMMENDS CONSULTING OUR TECHNICAL STAFF BEFORE DEPLOYING FIGARO SENSORS IN YOUR APPLICATION AND, IN PARTICULAR, WHEN CUSTOMER'S TARGET GASES ARE NOT LISTED HEREIN. FIGARO CANNOT ASSUME ANY RESPONSIBILITY FOR ANY USE OF ITS SENSORS IN A PRODUCT OR APPLICATION FOR WHICH SENSOR HAS NOT BEEN SPECIFICALLY TESTED BY FIGARO.

## 1. Basic Information

### 1-1 Features

- \* High selectivity to CO<sub>2</sub>
- \* Maintenance free
- \* Low power consumption
- \* Long life
- \* Compact size
- \* Pre-calibrated
- \* Low cost

### 1-2 Applications

- \* Indoor air quality control
- \* CO<sub>2</sub> monitors

### 1-3 Specifications

The specifications of CDM4161 are contained in Table 1. Depending on the customer's target concentration range, Figaro offers two versions of this module as indicated in Table 1. Customized modules are available according to special requests from customers. Please consult with Figaro.

### 1-4 Dimensions (see Fig. 1 below)

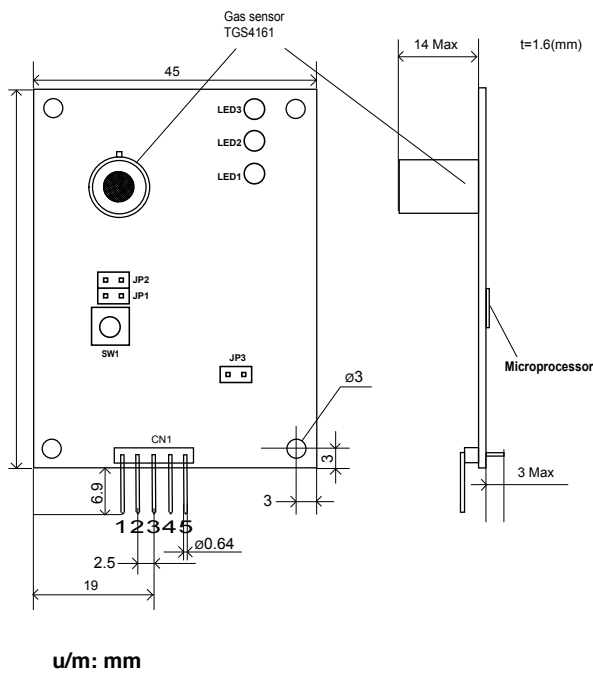

Fig. 1 - CDM4161 dimensions

## 2. Structure and Functions

### 2-1 Solid electrolyte CO<sub>2</sub> sensor TGS4161

The sensor changes its output voltage in response to exposure to CO<sub>2</sub> gas. The sensor should not be directly connected with low-input impedance equipment. To read sensor output, amplified voltage (CP4) should be used. Please refer to "TGS4161 Technical Information" for details as to the characteristics of the sensor.

### 2-2 Sensor's output signal voltage (CP4)

The sensor's output can be read as an amplified voltage (as taken from the differential amplifier). Voltage should be read from this port.

### 2-3 Microprocessor

The microcomputer takes data and renews it once per second. The processor calculates CO<sub>2</sub> concentrations based on the difference between current sensor output and a baseline value (which represents the sensor output value in fresh air).

### 2-4 Thermistor signal output voltage (CP3)

The thermistor's output signal voltage, which is used for compensation of the sensor's temperature dependency, can be read at this port.

### 2-5 Concentration setting for control signal (JP1, JP2)

Concentrations utilized for control signals (i.e. the control concentration) can be changed by modifying the settings of JP1 and JP2 as shown in Table 3. The module is pre-set at Mode I before shipment.

### 2-6 Baseline reset switch

The baseline value may be manually reset using this switch. When this switch is pushed, the sensor's

Pin No.	Name	Description
1	VIN	Power supply input
2	VCONC	CO <sub>2</sub> concentration output
3	CTRL	Control signal output
4	TRBL	Trouble signal output
5	GND	Common ground

Table 2 - CDM4161 pin designations of CN1  
**NOTE:** CN1 should be MB5P-90S, mfg. by JST.  
 Recommended receptacle for connector: 05JQ-BT, mfg. by JST.

# TECHNICAL INFORMATION FOR CDM4161

Product name	Carbon dioxide (CO <sub>2</sub> ) sensor module	
Model No.	CDM4161-L00	CDM4161-M00
Detection range	400 to 4,500ppm	400 to 9,000ppm
Sensor (principle)	TGS4161 (solid state electrolyte)	
Accuracy (*1)	approx. ±20% full scale	
Power supply	DC5.0±0.2V regulated	
Power consumption	300mW (typical)	
Inrush current	100mA (max)	
Operational temperature & humidity range	-10°~+50°C, 5~95%RH (avoid condensation)	
Storage temperature & humidity range	-20°~+60°C, 5~90%RH (pack in a moisture proof bag)	
Warm up time	2 hours	
CO <sub>2</sub> concentration signal (*2)	Continuous analog output proportional to CO <sub>2</sub> concentration	
	Vconc = CO <sub>2</sub> concentration/1,000 (DC 4.5V full scale)	Vconc = CO <sub>2</sub> concentration/2,000 (DC 4.5V full scale)
Control signal	ON: HIGH output (when CO <sub>2</sub> conc. exceeds threshold) OFF: LOW output	
	800/ 1,000/ 1,500/ 2,000 (ppm)	1,000/ 2,000/ 5,000/ 8,000 (ppm)
Malfunction signal	ON: LOW output (sensor malfunction) OFF: FLOAT NC	
LED display	Green LED: Lights while power is on (blinks during warm up)	
	Yellow LED: Blinks during trouble	
	Red LED: Lights when CO <sub>2</sub> concentration exceeds the threshold	
Reset switch	Establishes the ambient CO <sub>2</sub> concentration as 400ppm when pushed	
Dimensions	45 x 60 x 19mm (45 x 67 x 19mm incl. CN1)	

**Note 1:** Assumes benchmark is set accurately at 400ppm of CO<sub>2</sub>. This value does not contain long term drift.

**Note 2:** In this module, the CO<sub>2</sub> concentration is calculated by measuring the relative change of sensor output at the measuring point from sensor output in clean air (assumed to be 400ppm of CO<sub>2</sub>).

Table 1 - Specifications

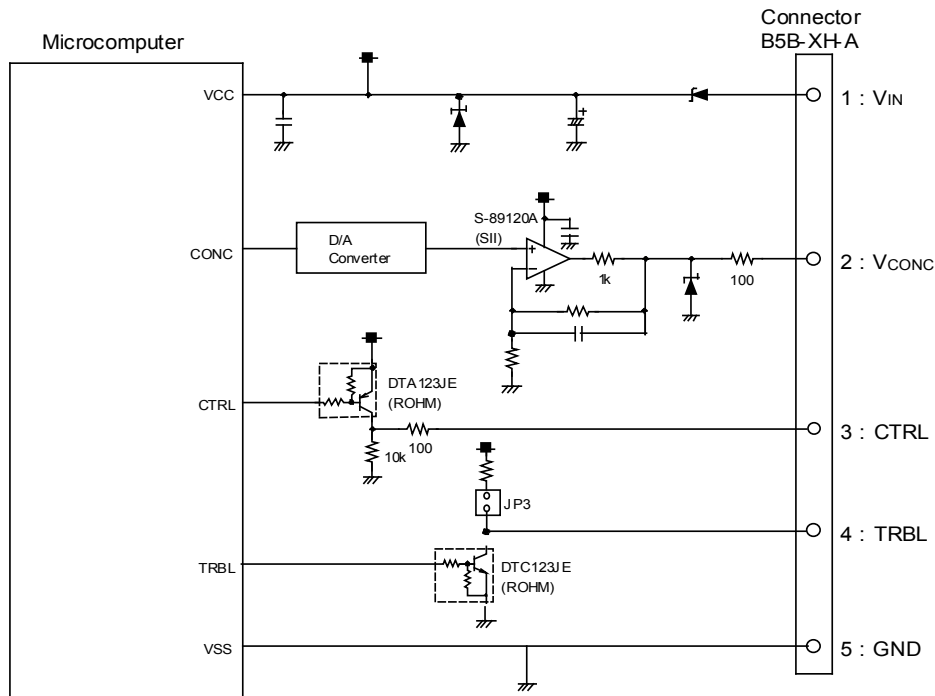

Fig. 2 - Circuit diagram of interface for circuit

output at that moment is memorized as 400ppm of CO<sub>2</sub> (the baseline value in fresh air). When the switch is pushed during warm-up time (within the first two hours after the module is powered on), the baseline voltage is read at that moment and the module immediately goes into operation mode.

**Caution:** If the baseline reset switch is pushed while in a polluted environment where the actual CO<sub>2</sub> concentration is higher than 400 ppm (ambient levels), the accuracy of readings may become adversely affected.

2-7 Input-output signal (CN1)

Please refer to *Table 4-Rated input and output voltages* for rated values. Also please refer to *Fig. 2-Circuit diagram of interface for circuit*.

2-7-1 Vin (Pin No. 1)

Regulated voltage should be input into this port. The sensor's output may vary according to the sensor's voltage dependency characteristics if the input voltage fluctuates. Please refer to "TGS4161 Technical Information" for details.

2-7-2 Concentration output (Pin No. 2)

An analog voltage corresponding to CO<sub>2</sub> concentration is output from this port according to the following equation:

$$\begin{aligned} \text{CDM4161-L00} : V_{\text{conc}} &= \text{CO}_2 \text{ conc} / 1000 \\ \text{CDM4161-M00} : V_{\text{conc}} &= \text{CO}_2 \text{ conc} / 2000 \end{aligned}$$

2-7-3 Control signal output (Pin No. 3)

When CO<sub>2</sub> concentrations exceed the control

Mode	JP1	JP2	Threshold CO <sub>2</sub> Concentration of Control Signal			
			CDM4161-L00		CDM4161-M00	
			ON	OFF	ON	OFF
I	OPEN	OPEN	800ppm	720ppm	1,000ppm	900ppm
II	OPEN	SHORT	1,000ppm	900ppm	2,000ppm	1,800ppm
II	SHORT	OPEN	1,500ppm	1,350ppm	5,000ppm	4,500ppm
IV	SHORT	SHORT	2,000ppm	1,800ppm	8,000ppm	7,200ppm

Table 3 - CDM4161 jumper pin settings

concentration, output from this port will be "ON".

2-7-4 Trouble signal output (Pin No. 4)

This port will output "ON" in the following situations:

- \* when the sensor's heater is broken
- \* when sensor output is abnormal
- \* when the connection for control concentration setting is broken

2-8 LEDs (refer to Table 5)

2-8-1 Green LED (LED 1)

The green LED indicates the module's power condition. It will be lit when the power is on. The LED blinks on and off during warm-up time (for the first two hours after power is turned on).

2-8-2 Yellow LED (LED 2)

The yellow LED indicates a trouble condition. It blinks on and off when trouble signal output is "ON".

2-8-3 Red LED (LED 3)

The red LED indicates that CO<sub>2</sub> concentration is over the control concentration level. It lights when control signal output is "ON".

Pin No.	Item		Minimum	Typical	Maximum	u/m
1	Power supply input (VIN)		3.5	5.0	5.5	V
2	CO <sub>2</sub> conc. output (VCONC)	Output voltage	GND	-	4.6	V
3	Control signal output (CTRL)	Output voltage (trouble) IOL=1mA	GND	-	0.2	V
		Output voltage (warmup) IOH=1mA	VIN-0.6	-	VIN	V
		Allowable current	-	-	25	mA
4	Trouble signal output (TRBL)	Output voltage Ic=5mA	-	-	0.3	V
		Allowable voltage	-	-	50	V
		Allowable current	-	-	100	mA

Table 4 - Rated input/output voltages

Condition	Green LED	Yellow LED	Red LED	Control signal (CTRL)	Trouble signal (TRBL)	CO2 concentration signal	
						CDM4161-L00	CDM4161-M00
Warm up period	Blink ON/OFF	OFF	OFF	OFF	OFF	0.4V	0.2V
CO2 Conc. < Threshold	ON	OFF	OFF	OFF	OFF	CO2 conc./1000V	CO2 conc./2000V
CO2 Conc. ≥ Threshold	ON	OFF	ON	ON	OFF	CO2 conc./1000V	CO2 conc./2000V
Trouble	ON	Blink ON/OFF	OFF	OFF	ON	4.5V	4.5V

Table 5 - Signal output in operation mode

### 3. Operation modes

#### 3-1 Warm up

The sensor is warmed up for two hours after the module is powered on. The green LED blinks on and off and a constant voltage (0.4V for -L00, 0.2V for -M00) is output from the concentration output port during this period. The green LED will be lit continuously after the warm-up period ends unless a power outage occurs.

#### 3-2 CO2 concentration lower than threshold level

The green LED will be on if the calculated CO2 concentration is lower than the threshold level.

#### 3-3 CO2 concentration exceeds threshold level

The red LED will be lit and the control signal output is turned "ON" if CO2 concentration exceeds the threshold level.

The control signal output is turned to "OFF" and the red LED will be off when CO2 concentration drops to 90% of the threshold level.

#### 3-4 Trouble

Whenever a trouble situation occurs, such as heater breakage, the yellow LED blinks on and off and the TRBL signal is set to "ON".

### 4. Cautions

1) By assuming that the baseline level represents fresh air (400ppm of CO2), actual CO2 concentrations are calculated based on the difference between the baseline level and the current sensor output. As a result, the following cautions should be noted:

a) Accurate readings cannot be expected if an accurate baseline could not be acquired.

b) The sensor should be exposed to fresh air periodically to properly renew the baseline level. Performance shown in the specifications cannot be achieved if the module was used in an environment

where CO2 concentrations increased slowly and steadily for a long period of time.

c) The module should be located in fresh air during the warm-up period. Accurate readings cannot be expected until the baseline is acquired in fresh air. If the module is warmed up in an environment where CO2 concentration is higher than normal fresh air, the baseline will represent a polluted level and the device will not be able to clean the air sufficiently.

d) Power should be on at all times. Since the baseline is memorized in a microcomputer, if the power should be cut off, the memory would be lost and operation would resume from the warm-up process.

e) The module is not intended for usage in life saving equipment. If the module is incorporated into life saving equipment, an alternative and secure measure for calculating CO2 concentration should be used for the life safety function.

2) This module is designed only for indoor usage. The module should be protected from exposure to rain, wind, sun, heat radiation, etc.

3) Please apply a regulated voltage, otherwise the accurate reading cannot be expected. Application of excessive and/or reverse voltage would cause damage to the module.

4) The sensor may deteriorate if it is stored without power in a high humidity environment for a long period of time. Please keep the sensor in a humidity-proof bag with a desiccant if the sensor is to be stored without power for a long period of time.

5) Please refer to "TGS4161 Technical Information" for other handling precautions of TGS4161.

### 5. Important Notice

Figaro Engineering Inc. (Figaro) reserves the right to make changes without notice to any products herein to improve reliability, functioning or design.

Information contained in this document is believed to be reliable. However, Figaro does not assume any liability arising out of the application or use of any product or circuit described herein; neither does it convey any license under its patent rights, nor the rights of others.

**IMPORTANT NOTE**

This product is not designed and authorized for use as a component in life support applications wherein a failure or malfunction of the products may result in injury or threat to life. Figaro Engineering Inc. reserves the right to make changes to this product without notice to improve reliability, functioning, and/or design.

**FIGARO GROUP**

HEAD OFFICE

**Figaro Engineering Inc.**

1-5-11 Senba-nishi  
Mino, Osaka 562-8505 JAPAN  
Tel.: (81) 72-728-2561  
Fax: (81) 72-728-0467  
email: [figaro@figaro.co.jp](mailto:figaro@figaro.co.jp)  
[www.figaro.co.jp](http://www.figaro.co.jp)

OVERSEAS

**Figaro USA Inc.**

121 S. Wilke Rd. Suite 300  
Arlington Heights, IL 60005 USA  
Tel.: (1) 847-832-1701  
Fax.: (1) 847-832-1705  
email: [figarousa@figarosensor.com](mailto:figarousa@figarosensor.com)  
[www.figarosensor.com](http://www.figarosensor.com)