

FIGARO

an ISO9001 company



**Technical Information for Carbon Dioxide Sensor Module AM-4 for detection up to 3000ppm**

The Figaro AM-4 is a carbon dioxide sensor module which is useful for evaluating the application of Figaro's solid electrolyte CO<sub>2</sub> sensor TGS4160 into air quality control products. The module contains a gas sensor, microprocessor, and control circuit. The AM-4 is designed for detecting CO<sub>2</sub> concentrations up to 3000ppm. For detection at concentrations greater than 3000ppm, please refer to the Technical Information for AM-4-H.

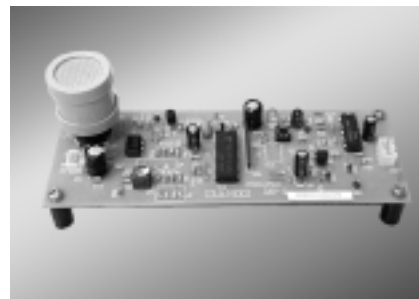

	<u>Page</u>
<i>Product Description</i> .....	2
<i>Components</i> .....	2
<i>Performance</i>	
Warmup operation.....	3
Standard operation.....	3
<i>Troubleshooting</i> .....	4
<i>Specifications</i> .....	4
<i>Notes</i> .....	4
<i>Circuit Diagram</i> .....	5

**IMPORTANT NOTE:** OPERATING CONDITIONS IN WHICH FIGARO SENSORS ARE USED WILL VARY WITH EACH CUSTOMER'S SPECIFIC APPLICATIONS. FIGARO STRONGLY RECOMMENDS CONSULTING OUR TECHNICAL STAFF BEFORE DEPLOYING FIGARO SENSORS IN YOUR APPLICATION AND, IN PARTICULAR, WHEN CUSTOMER'S TARGET GASES ARE NOT LISTED HEREIN. FIGARO CANNOT ASSUME ANY RESPONSIBILITY FOR ANY USE OF ITS SENSORS IN A PRODUCT OR APPLICATION FOR WHICH SENSOR HAS NOT BEEN SPECIFICALLY TESTED BY FIGARO.

### 1. Product Description

The AM-4 is a new CO<sub>2</sub> sensor module which can be used for automatic ventilation systems or CO<sub>2</sub> gas monitoring. The module's output voltage is linearized relative to CO<sub>2</sub> gas concentration.

The AM-4 unit is made up of the TGS4160 CO<sub>2</sub> sensor and the FIC98648 microprocessor. The purpose of AM-4 is to help users understand and evaluate the features of its components by observing their actual performance.

TGS4160 is a solid electrolyte type gas sensor whose output voltage / electromotive force decreases as CO<sub>2</sub> gas concentration increases.

FIC98648 is a special microprocessor which generates a linearized output voltage and a control signal for driving a ventilation system relative to CO<sub>2</sub> gas concentration. This microprocessor compensates the temperature dependency of TGS4160 by checking the output signal from the sensor's internal thermistor against a look-up table of compensation factors. While the absolute value of the sensor's electromotive force (EMF) will change over time, the difference in EMF between various concentrations of CO<sub>2</sub> gas ( $\Delta$ EMF) remains constant.

To compensate for changes over time to absolute EMF values, a 'benchmark' value of EMF, representing the value of ambient CO<sub>2</sub> in fresh air (350~400ppm CO<sub>2</sub>), should be periodically reset. The procedure for reset of the benchmark is as follows (see Fig. 1) :

- a) initial benchmark is set at a point 2 hours after powering on.
- b) each reset of benchmark begins a 24-hour timer in the microprocessor during which time, if a higher

output voltage than the benchmark is measured, the new higher value would be replaced in the microprocessor's memory as the benchmark (and resetting the 24-hour timer).

- c) if the timer reaches 24 hours without the benchmark being replaced, then a new benchmark would be established at a voltage value corresponding to 20ppm of CO<sub>2</sub> lower than the most recent benchmark.

### 2. Components

Figure 2 (opposite) shows the components of AM-4 and their functions:

- a. *Input terminal (CN1):*  
 Pin 1: DC 5.0 ± 0.2V  
 Pin 2: GND
- b. *Output terminal (CN2):*  
 Pin 1: Gas concentration output signal  
 0.0 ~3.0V, corresponding to  
 0 ~ 3,000 ppm CO<sub>2</sub> gas  
 Pin 2: Control signal for relay  
 High: 5V, Red LED = on  
 Low: 0V, Green LED = on  
 Pin 3: GND

- c. *TGS4160-Solid electrolyte CO<sub>2</sub> gas sensor:*  
 The sensor's EMF / output voltage decreases as CO<sub>2</sub> gas concentration increases.

- d. *Microprocessor FIC 98648*  
 The microprocessor will read the sensor output signal from sensor Pin #3, compensate it for temperature by using the internal thermistor signal from sensor Pin #2, compare the result to the benchmark level (ambient CO<sub>2</sub>), calculate the CO<sub>2</sub> concentration, and generate the gas concentration and control signals.

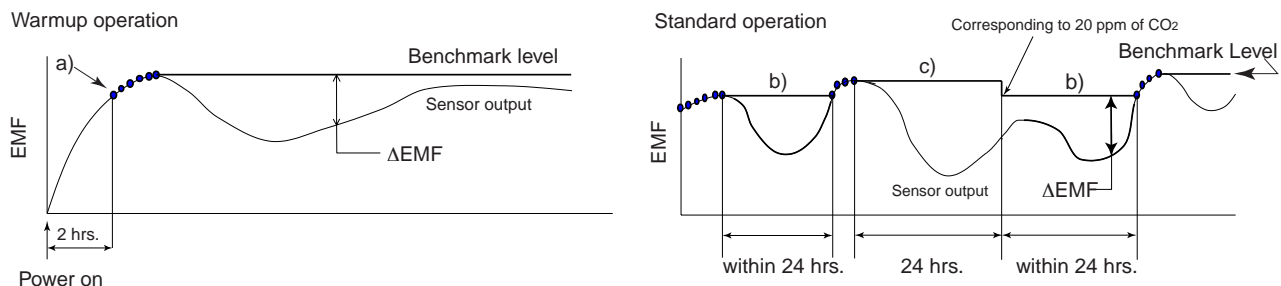

Figure 1 - AM-4 benchmark reset procedure

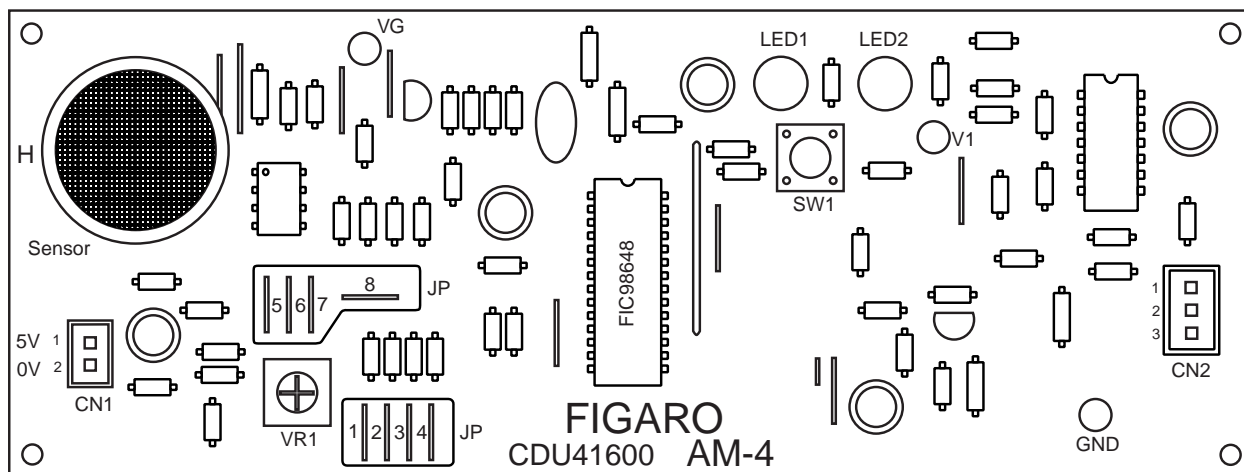

Figure 2 - AM-4 Components

e. LEDs

Initial warmup operation:

Green LED=blinking

Standard operation:

Green LED=on, when CO2 is below the threshold level (L)

Red LED=on, when CO2 is beyond the threshold level (H)

Sensor/Microprocessor trouble:

Red LED=blinking

f. Reset switch (SW1)

This switch allows for manual resetting of the benchmark value (ambient CO2). Normally this value is automatically renewed in the microprocessor according to the procedure outlined in Item 1.

**CAUTION:** When the reset switch is pushed, the software recognizes the CO2 concentration at that time as a benchmark value for ambient CO2. If the reset switch would be pushed while elevated CO2 levels are present, the gas concentration output signal would display poor sensitivity/accuracy for up to 24 hours.

g. Variable resistor (VR1)

Factory preset and sealed—do not change setting.

3. Performance

After power on, the AM-4 goes through a warmup operation for two hours, after which it goes into standard operation.

a. Warmup operation

To obtain a stable output voltage for TGS4160 and to

determine the benchmark sensor output voltage, the AM-4 drives a warmup operation for two hours after being powered. During warmup, the Green LED blinks, an active “L” control signal is generated, and a gas concentration output signal of <500mV is generated, regardless of CO2 concentration.

**NOTE:** If elevated CO2 levels exist at the time of powering on, the baseline level would be set at a polluted level, resulting in poor sensitivity and accuracy for up to 24 hours.

b. Standard operation

AM-4 compares the calculated CO2 concentration against a threshold level (see p. 4 for setting the threshold) and the following actions would be initiated:

CO2 Level	LED	Control Signal
Below threshold	Green	Low
Above threshold	Red	High

Table 1 - AM-4 actions based on CO2 readings

As previously mentioned, the change over time in absolute EMF value is compensated for by the microprocessor periodically memorizing a new benchmark EMF value. By comparing the measured EMF value of the sensor to the memorized benchmark value and compensating for temperature, gas concentration can be calculated.

Regarding the threshold level, AM-4 is capable of providing the four different setup modes shown

below:

Mode	Control Signal Threshold (CO <sub>2</sub> )	
	On	Off
I	800ppm	720ppm
II	1,000ppm	900ppm
III	1,500ppm	1,350ppm
IV	2,000ppm	1,800ppm

Table 2 - AM-4 threshold setup modes

The factory preset default mode is set to "I". To adjust the setup mode, connect the jumper pins according to the following table:

Mode	JP5	JP6	JP7	JP8
I	connect	connect	connect	cut
II	connect	connect	cut	connect
III	connect	cut	connect	connect
IV	cut	connect	connect	connect

Table 3 - AM-4 jumper connections for threshold setup

The AM-4 in standard operation mode generates a temperature compensated gas concentration output signal from 0~3.0 V corresponding to 0~3,000ppm of CO<sub>2</sub> gas.

#### 4. Troubleshooting

Problem	Cause	Solution
All LED's off	drop in power or disconnection	check power connections
	no power	check power
Red LED blinking	abnormal sensor output signal	call for repair
	abnormal for bias circuit	
Other	malfunction of microcomputer caused by external noise	disconnect power, reconnect, and restart
	other	call for repair

Table 4 - AM-4 troubleshooting

#### 5. Specifications

Item	Specification	
Power Supply	DC 5.0V ± 0.2V	
Power Consumption	Maximum 1.5W	
Target Gas	CO <sub>2</sub>	
Detection range	ambient ~ 3000ppm CO <sub>2</sub>	
LED display	LED (green)	ON when CO <sub>2</sub> conc. below threshold
	LED (red)	ON when CO <sub>2</sub> conc. above threshold
Output terminals (max. 50mA)	Pin 1	0~3.0V DC
	Pin 2	High = 5.0V DC Low = 0V DC
	Pin 3	GND
Operational temp/humidity range	-10 ~ 40°C, 5 ~ 70%RH (avoid condensation on the unit)	
Storage temperature/humidity range	-20 ~ 60°C, 5~90%RH% (should be packed in a moisture proof bag)	
Dimensions	140mm x 45mm x 40 mm	

#### 6. Notes

a. The sensor should be installed under the following conditions:

- 1) Indoor location, avoiding exposure to rain, direct sunlight and radiant heat.
- 2) Do not place where vibration may occur.
- 3) The sensor should not be directly exposed human breath.

b. As this unit is designed for evaluation only, the operational stability against fluctuation of power supply voltage or external noise is not specified.

c. AM-4 is not designed for analytical measurement of absolute CO<sub>2</sub> values. As such, it is not intended for usage as a CO<sub>2</sub> concentration meter.

d. Since the sensing element is heated, the gauze of the sensor cap usually gets warm. This is not abnormal.

7. Circuit diagram (Figure 3)

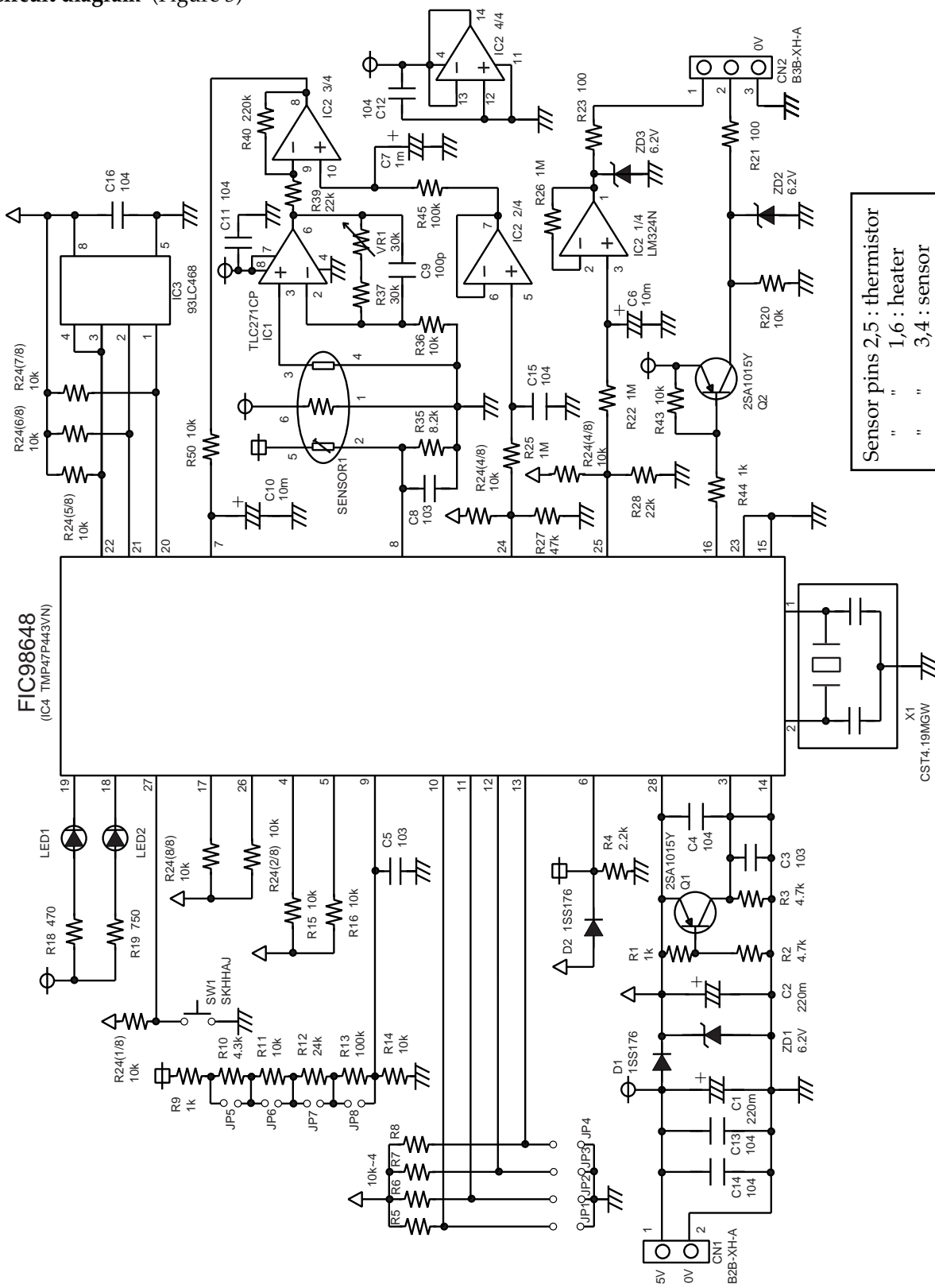

Figaro Engineering Inc. (Figaro) reserves the right to make changes without notice to any products herein to improve reliability, functioning or design. Information contained in this document is believed to be reliable. However, Figaro does not assume any liability arising out of the application or use of any product or circuit described herein; neither does it convey any license under its patent rights, nor the rights of others.

Figaro's products are not authorized for use as critical components in life support applications wherein a failure or malfunction of the products may result in injury or threat to life.

**FIGARO GROUP**

**HEAD OFFICE**

**Figaro Engineering Inc.**  
1-5-11 Senba-nishi  
Mino, Osaka 562 JAPAN  
Tel.: (81) 72-728-2561  
Fax: (81) 72-728-0467  
email: [figaro@figaro.co.jp](mailto:figaro@figaro.co.jp)

**OVERSEAS**

**Figaro USA Inc.**  
3703 West Lake Ave. Suite 203  
Glenview, IL 60025 USA  
Tel.: (1) 847-832-1701  
Fax.: (1) 847-832-1705  
email: [figarousa@figarosensor.com](mailto:figarousa@figarosensor.com)