

TGS 2106 - for detection of Diesel Engine Exhaust Gas

Features:

- * High sensitivity to exhaust gases emitted by diesel-fueled engines
- * Long life and low cost
- * Uses simple electrical circuit

Applications:

- * Automobile ventilation control

The sensing element is comprised of a metal oxide semiconductor layer formed on an alumina substrate of a sensing chip together with an integrated heater. In the presence of a detectable gas, the sensor's conductivity decreases depending on the gas concentration in the air. A simple electrical circuit can convert the change in conductivity to an output signal which corresponds to the gas concentration.

The **TGS 2106** has high sensitivity and quick response to exhaust gases emitted by diesel-fueled engines. As a result of this feature, TGS2106 is an ideal sensor for application in automatic damper control systems for automobile ventilation.



The figure below represents typical sensitivity characteristics, all data having been gathered at standard test conditions (see reverse side of this sheet). The Y-axis is indicated as *sensor resistance ratio* (R_s/R_o) which is defined as follows:

- R_s = Sensor resistance in displayed gases at various concentrations
- R_o = Sensor resistance in clean air

Sensitivity Characteristics:

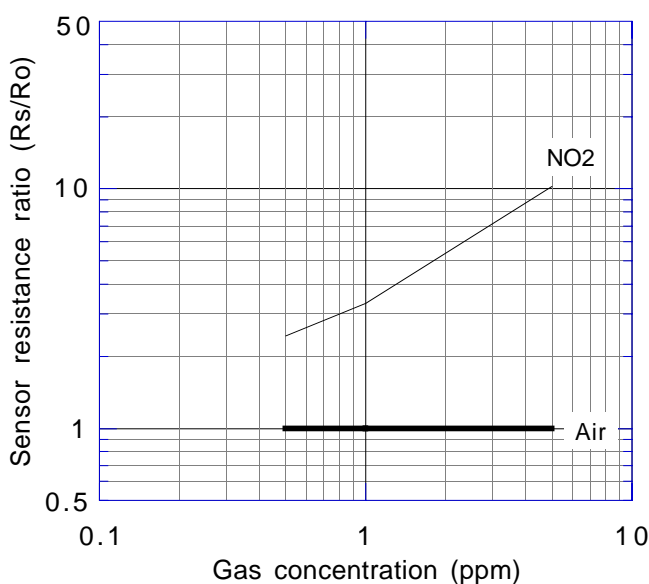

The figure below represents the typical response pattern of the TGS2106 when the atmosphere changes from clean air to the listed gas concentrations and then reverts back to clean air again.

Sensor Response Pattern:

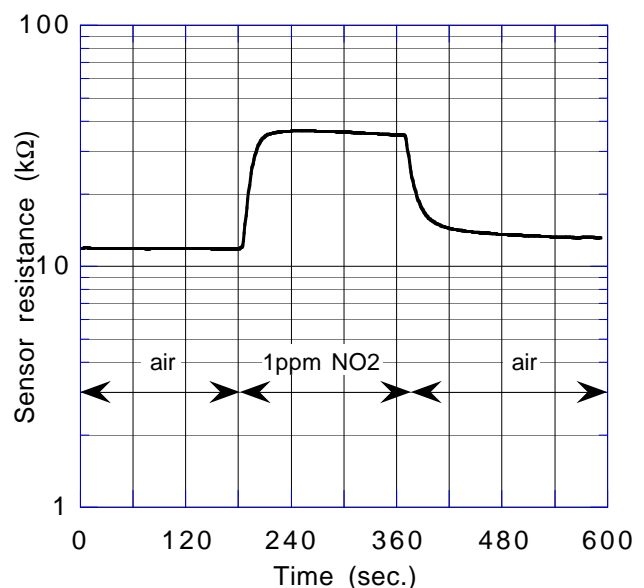

IMPORTANT NOTE: OPERATING CONDITIONS IN WHICH FIGARO SENSORS ARE USED WILL VARY WITH EACH CUSTOMER'S SPECIFIC APPLICATIONS. FIGARO STRONGLY RECOMMENDS CONSULTING OUR TECHNICAL STAFF BEFORE DEPLOYING FIGARO SENSORS IN YOUR APPLICATION AND, IN PARTICULAR, WHEN CUSTOMER'S TARGET GASES ARE NOT LISTED HEREIN. FIGARO CANNOT ASSUME ANY RESPONSIBILITY FOR ANY USE OF ITS SENSORS IN A PRODUCT OR APPLICATION FOR WHICH SENSOR HAS NOT BEEN SPECIFICALLY TESTED BY FIGARO.

Basic Measuring Circuit:

The sensor requires two voltage inputs: heater voltage (V_H) and circuit voltage (V_C). The heater voltage (V_H) is applied to the integrated heater in order to maintain the sensing element at a specific temperature which is optimal for sensing. Circuit voltage (V_C) is applied to allow measurement of voltage (V_{RL}) across a load resistor (R_L) which is connected in series with the sensor.

A common power supply circuit can be used for both V_C and V_H to fulfill the sensor's electrical requirements. The value of the load resistor (R_L) should be chosen to optimize the alarm threshold value, keeping power dissipation (P_S) of the semiconductor below a limit of 15mW. Power dissipation (P_S) will be highest when the value of R_S is equal to R_L on exposure to gas.

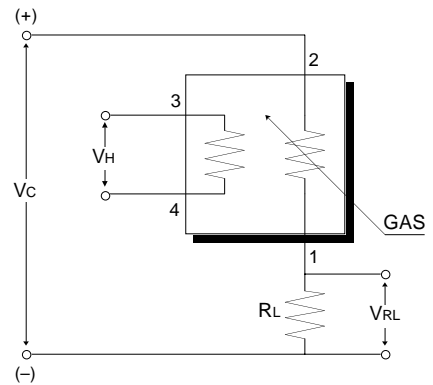

Specifications:

Model number		TGS 2106	
Sensing element type		S1	
Standard package		Plastic (blue)	
Target gases		Diesel exhaust (NO ₂)	
Typical detection range		0.1 ~ 10 ppm	
Standard circuit conditions	Heater voltage	V_H	6.2V DC \pm 5%
	Circuit voltage	V_C	15.0V DC Max. $P_S \leq 15mW$
	Load resistance	R_L	Variable $P_S \leq 15mW$
Electrical characteristics under standard test conditions	Heater resistance	R_H	50 Ω \pm 10% at room temp.
	Heater current	I_H	87mA
	Heater power consumption	P_H	539mW $V_H = 6.2V$ DC
	Sensor resistance	R_S	5 ~ 50k Ω in air
	Sensitivity (change ratio of R_S)		2.0 ~ 7.0 $R_S(0.5ppm \text{ of NO}_2) / R_S(\text{air})$
Standard test conditions	Test gas conditions	Air at 20 \pm 2 $^\circ$ C, 65 \pm 5%RH	
	Circuit conditions	$R_L = 10k\Omega \pm 1\%$, $V_C = 6.2V$ DC \pm 3%, $V_H = 6.2V$ DC \pm 3%	
	Conditioning period before test	2~7 days	

The value of power dissipation (P_S) can be calculated by utilizing the following formula:

$$P_S = \frac{(V_C - V_{RL})^2}{R_S}$$

Sensor resistance (R_S) is calculated with a measured value of V_{RL} by using the following formula:

$$R_S = \frac{V_C - V_{RL}}{V_{RL}} \times R_L$$

For information on warranty, please refer to Standard Terms and Conditions of Sale of Figaro USA Inc.

REV: 2/01

Structure and Dimensions:

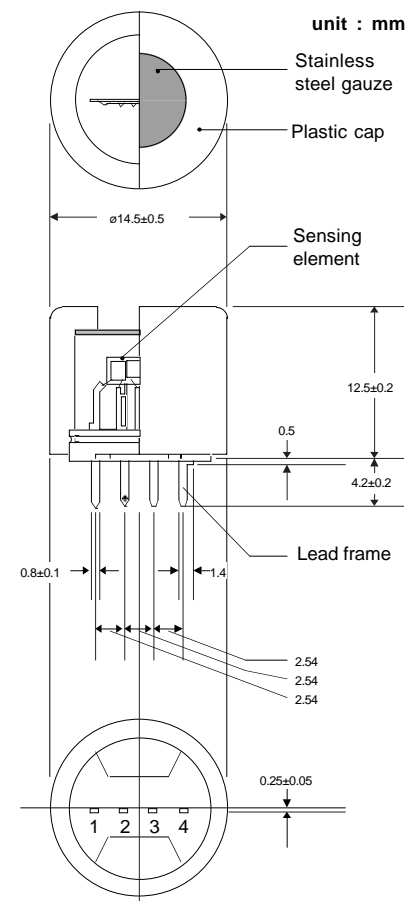

Pin connection

- 1: Sensor electrode(-)
- 2: Sensor electrode(+)
- 3: Heater(+)
- 4: Heater(-)

FIGARO USA, INC.

3703 West Lake Ave. Suite 203
Glenview, Illinois 60025
Phone: (847)-832-1701
Fax: (847)-832-1705
email: figarousa@figarosensor.com