

1

2

3

4

A

A

B

B

C

C

D

D

		Core range					
8638PSS4005	8638PSS4005LF	40	8	Section 8.98 mm ² Ø Ame 3.90 mm	4.40	5.50	blue
8638PSS2005	8638PSS2005LF	20	12	Section 3.18 mm ² Ø Ame 2.40 mm	2.80	3.65	red
8638PSS1005	8638PSS1005LF	10	16	Section 1.34 mm ² Ø Ame 1.50 mm	1.70	2.60	black
TIN LEAD PART NUMBER	LEAD FREE PART NUMBER	CURRENT max A	AWG	mm ² WIRE AREA	ØA ^{+0.10} -0	ØB ^{+0.10} -0	COLOUR CLIP

NOTE:RoHS INFORMATIONS

- The "LF" products meet European union Directives and other country regulations as described in 65-22-008.
- Termination plating spec: Cu 2 +0 +2 µm, Sn 3 +0 +3µm (pure matte)
- active area:CuZn40 Pb3 1µNi+gold
- Packaging spec: see 65-14-920

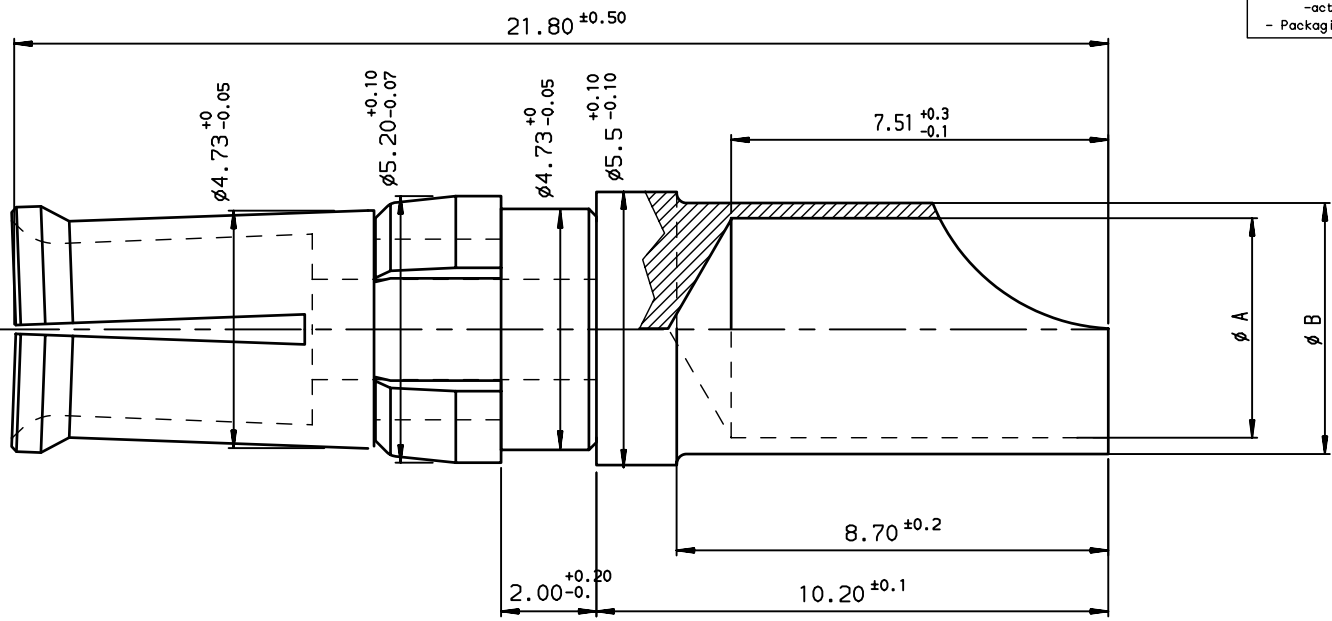

Materials and finish for TIN LEAD

contact:CuZn40 Pb3 1µNi+gold
 Solder buckets:CuZn36Pb3 2µNi+2µSnPb mini
 Clip : plastic
Technical characteristics
 Peak voltage: 750Veff.
 Operating voltage: 500Veff.
 Temperature range:-55°C ÷125°C
 Packaging per 100
 Current capability see table

Mechanical characteristics:

Mechanical endurance : > 200 matings/unmatings .
 Contact insertion force in insulator:
 60N maxi in a hole of 4.80mm

Examination of product:

Remove all burns and sharp edges 0.08 maxi
 No scratch on all pieces

European Views

www.fciconnect.com		surface ISO 1302 ✓	tolerance std ISO 406 ISO 1101	projection A3	mm Scale 10
TOLERANCES UNLESS OTHERWISE SPECIFIED					
Dr	JARRY	1994/12/13	ANGULAR	0.X	±0.1
Eng	PESSON	1994/12/13	LINEAR	0.XX	±0.1
Chr	LEGARE	1994/12/13		0.XXX	±0.1
Appr	LEGARE	1994/12/13	Product family		D-SUB
				size	ECN LS08-0029
				Spec ref	-
title FEMALE CONTACT FOR SOLDER CONNECTION			dwg no C01-8638-0335-1		Rev. H
catalog no			CUSTOMER		sheet 1 of 1

rev	ecn no	dr	date
D	-	JAR	2002/03/13
E	LS05-005	MPE	2005/04/05
F	LS06-0097	LGO	2006/07/27
G	LS07-0059	MPE	2006/02/27
H	LS08-0029	MPE	2008/01/28
-	-	-	-
-	-	-	-

Copyright FCI. **FCI**

REV F - 2006-04-17

1

2

3

4