

		Core range					
8638PPS4005	8638PPS4005LF	40	8	Section 8.98 mm <sup>2</sup> Ø Ame 3.90 mm	4.40	5.50	blue
8638PPS2005	8638PPS2005LF	20	12	Section 3.18 mm <sup>2</sup> Ø Ame 2.40 mm	2.80	3.65	red
8638PPS1005	8638PPS1005LF	10	16	Section 1.34 mm <sup>2</sup> Ø Ame 1.50 mm	1.70	2.60	black
TIN LEAD PART NUMBER	LEAD FREE PART NUMBER	CURRENT max A	AWG	mm <sup>2</sup>	ØA <sup>+0.10</sup> -0	ØB <sup>+0.10</sup>	COLOUR CLIP
			WIRE AREA				

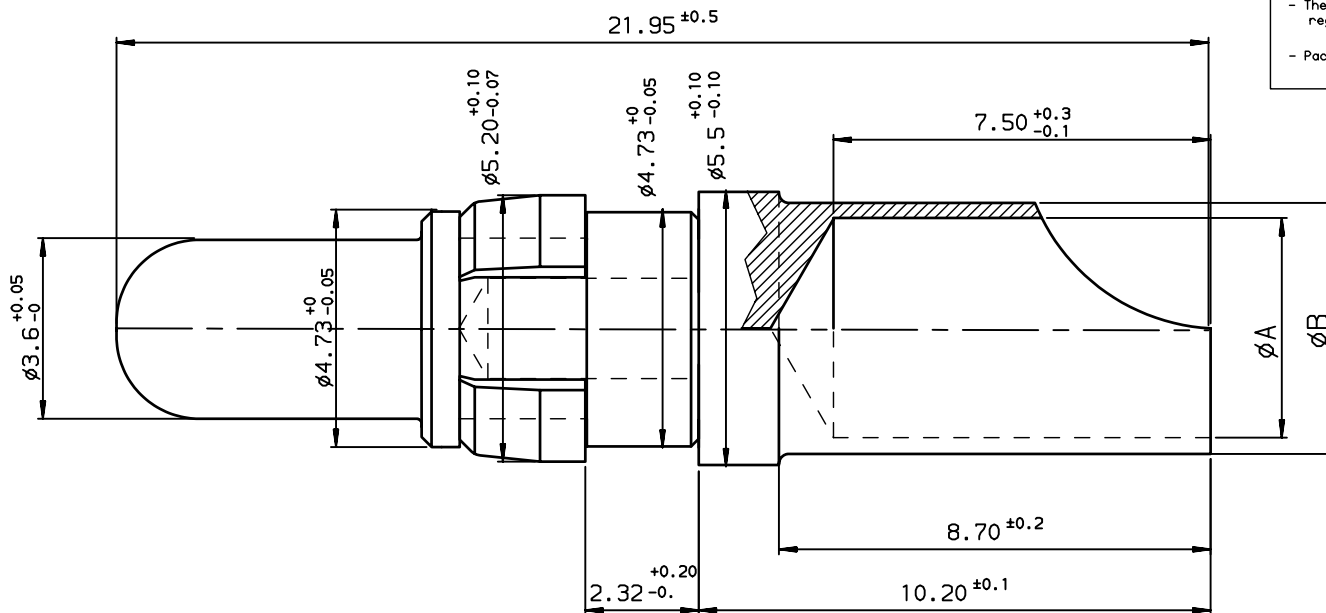

**NOTE:RoHS INFORMATIONS**

- The "LF" products meet European union Directives and other country regulations as described in 65-22-008.
- Termination plating spec: Cu 2 +0 +2 um, Sn 3 +0 +3µm (pure matte)
- Packaging spec: see 65-14-920 contact:CuZn40 Pb3 1µNi+gold

**Materials and finish for TIN LEAD**

contact:CuZn40 Pb3 1µNi+gold  
 Solder buckets:CuZn36Pb3 2µNi+2µSnPb mini  
 Clip : plastic  
**Technical characteristics**  
 Peak voltage: 750Veff.  
 Operating voltage: 500Veff.  
 Temperature range:-55°C ÷125°C  
 Packaging per 100  
 Current capability see table

**Mechanical characteristics:**  
 Mechanical endurance : > 200 matings/unmatings .  
 Contact insertion force in insulator:  
 60N maxi in a hole of 4.80mm  
**Examination of product:**  
 Remove all burrs and sharp edges 0.08 maxi  
 No scratch on all pieces

**European Views**

www.fciconnect.com		surface ISO 1302 ✓	tolerance std ISO 406 ISO 1101	projection A3	mm
TOLERANCES UNLESS OTHERWISE SPECIFIED					
Dr	JARRY	1994/12/12	0.X	±0.1	size A3
Eng	PESSON	1994/12/12	0.XX	±0.1	
Chr	LEGARE	1994/12/12	0.XXX	±0.1	
Appr	LEGARE	1994/12/12	ANGULAR 0.XX' ±2'	LINEAR	ECN LS08-0029
Product family				D-SUB	Spec ref -
		<b>MALE POWER CONTACT FOR SOLDER CONNECTION</b>		dwg no <b>C01-8638-0334-1</b>	Rev. <b>G</b>
catalog no		-		CUSTOMER	sheet 1 of 1

rev	ecn no	dr	date
D	-	BAR	2003/04/17
E	LS05-005	MPE	2005/04/05
F	LS06-0097	LGO	2006/07/27
G	LS08-0029	MPE	2008/01/28
-	-	-	-
-	-	-	-
-	-	-	-

Copyright FCI. FCJ