

FOR 15P

REMARK:

1. CHARACTERISTICS:

RATED VOLTAGE: 250V
 RATED CURRENT: 2.5AMP
 CONTACT RESISTANCE: 25mohms MAX. INITIAL,
 40mohms MAX. AFTER.
 INSULATION RESISTANCE: 5000Mohms MIN. at 500V DC
 DIELECTRIC STRENGTH: 750VRMS
 OPERATING TEMPERATURE RANGE: -55° C~105° C
 INSERTION/EXTRACTION FORCE PER CONTACT: 5N Max./0.2N Min.
 MATING/UNMATING CYCLES: 200MATINGS MIN FOR GOLD-FLASH
 500MATINGS MIN FOR 30u" GOLD.

2. MATERIAL:

INSULATORS: THERMOPLASTIC G. F (UL94V-0) BLACK
 CONTACTS: COPPER ALLOY, GOLD(G/F or 30U") TOP OVER CONTACT
 AREA, 100u" Min MATTE TIN TOP OVER SOLDER AREA,
 50u" Min NICKEL UNDER PLATE.
 SHELL: CARBON STEEL, 100u" Min NICKEL TOP OVER,
 50u" Min COPPER UNDER PLATE.
 HARPOON: COPPER ALLOY , 100u" Min MATTE TIN PLATED.

3. PART NUMBER DESCRIPTION:

10090929-S XX X X LF

SERIES NO. _____ LF: ROHS COMPLIANT
 TYPE _____ FLANGE MOUNTING OPTION
 S: SOCKET (FEMALE) X: UNC #4-40 CLINCHNUTS
 NUMBER OF CONTACTS _____ CONTACT FINISH
 15: 15-PIN 4: FLASH GOLD
 26: 26-PIN 6: 30u" GOLD
 44: 44-PIN
 62: 62-PIN

POS.	PART NO.	THREAD TYPE
15	10090929-S15*XLF	UNC #4-40
26	10090929-S26*XLF	UNC #4-40
44	10090929-S44*XLF	UNC #4-40
62	10090929-S62*XLF	UNC #4-40

POS.	A	B	C	D	E
15	30.81	24.99	16.33	2.29	19.10
26	39.24	33.32	24.66	2.29	27.75
44	53.04	47.04	38.38	2.29	41.30
62	69.32	63.50	54.84	2.41	57.40

mat'l. code		surface		tolerance		projection		product family	
-		ISO 1302		ISO 406 ISO 1101				D-SUB	
ltr ecn no dr date		tolerances unless otherwise specified		angles				title	
A T09-1156 J.H 12/10/09		.02 .38		0°±2'		scale 2:1		H/D D-SUB FEMALE STRAIGHT	
B T10-0164 J.H 10/19/10		.00±.25		.000±.010				sheet 1 of 5 size	
C ELX-1-15500 A.B 2013-08-21		0°±2'		.000±.010		10090929		A4	
D ELX-1-18426 A.B 2014-07-29		dr		JASON.HSU 12/10/09		dwg no		sheet 1 of 5 size	
		engr		ALIAS.BABU 2014-07-29		10090929		A4	
		chr		MITHUN.PAUL 2014-07-29		type		PRODUCT_CUSTOMER DRAWING	
		appd		BIJU.K.PAUL 2014-07-29					
sheet index	revision sheet	D 1	D 2	D 3	D 4	D 5			



REMARK:

1. CHARACTERISTICS:

RATED VOLTAGE: 250V
 RATED CURRENT: 2.5AMP
 CONTACT RESISTANCE: 25mohms MAX. INITIAL,
 40mohms MAX. AFTER.
 INSULATION RESISTANCE: 5000Mohms MIN. at 500V DC
 DIELECTRIC STRENGTH: 750VRMS
 OPERATING TEMPERATURE RANGE: -55° C~105° C
 INSERTION/EXTRACTION FORCE PER CONTACT: 5N Max. /0.2N Min.
 MATING/UNMATING CYCLES: 200MATINGS MIN FOR GOLD-FLASH
 500MATINGS MIN FOR 30u" GOLD.

2. MATERIAL:

INSULATORS: THERMOPLASTIC G. F (UL94V-0) BLACK
 CONTACTS: COPPER ALLOY, GOLD(G/F or 30u") TOP OVER CONTACT
 AREA, 100u" Min MATTE TIN TOP OVER SOLDER AREA,
 50u" Min NICKEL UNDER PLATE.
 SHELL: CARBON STEEL, 100u" Min NICKEL TOP OVER,
 50u" Min COPPER UNDER PLATE.
 HARPOON: COPPER ALLOY , 100u" Min MATTE TIN PLATED.
 NUT: COPPER ALLOY , 50u" Min NICKEL PLATED.

3. PART NUMBER DESCRIPTION:

10090929-S XX X V LF
 SERIES NO. _____ LF: ROHS COMPLIANT
 TYPE _____ FLANGE MOUNTING OPTION
 S: SOCKET (FEMALE) V: UNC #4-40 SCREWLOCKS
 NUMBER OF CONTACTS _____ CONTACT FINISH
 15: 15-PIN 4: FLASH GOLD
 26: 26-PIN 6: 30u" GOLD
 44: 44-PIN
 62: 62-PIN

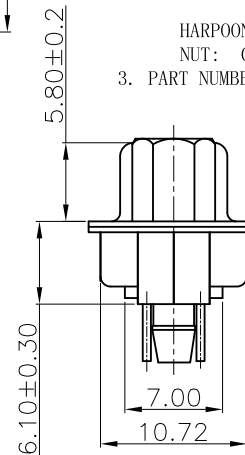
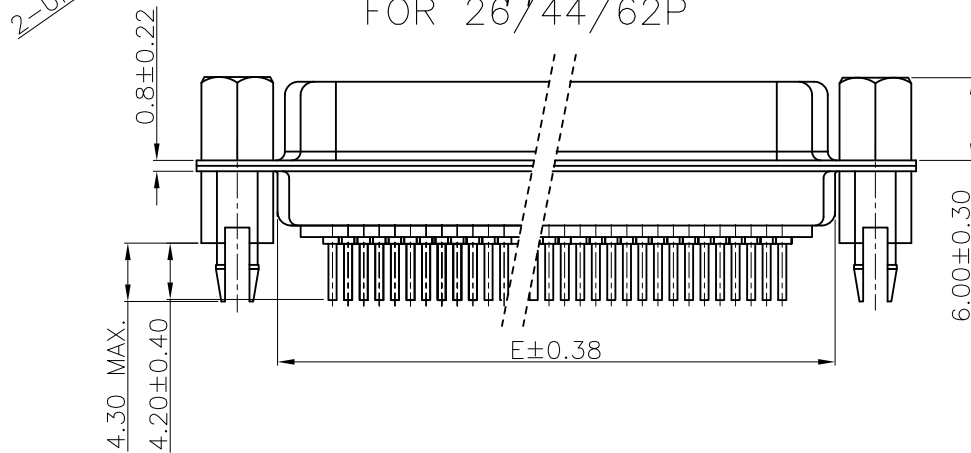
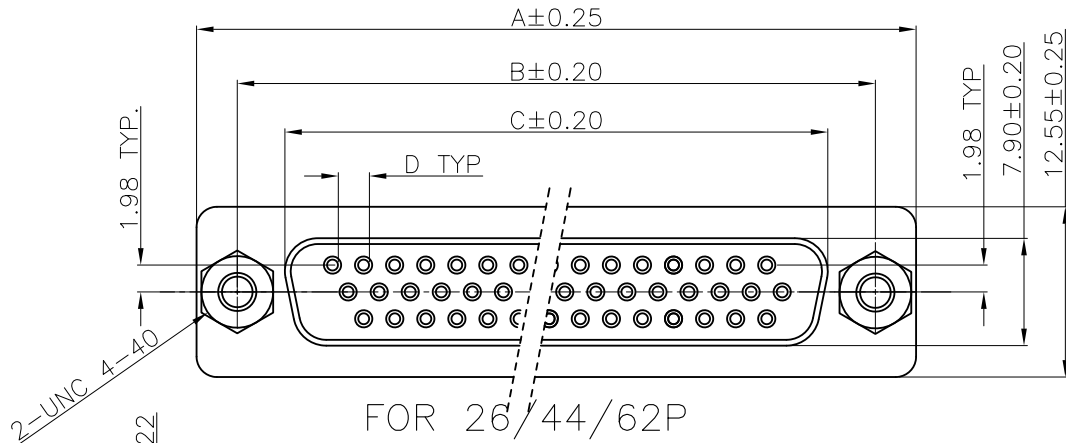

POS.	A	B	C	D	E
15	30.81	24.99	16.33	2.29	19.10
26	39.24	33.32	24.66	2.29	27.75
44	53.04	47.04	38.38	2.29	41.30
62	69.32	63.50	54.84	2.41	57.40

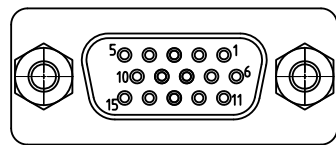

FOR 15P

mat'l. code	surface	tolerance	projection	product family
-	ISO 1302 ✓	ISO 406 ISO 1101		D-SUB
ltr	ecn no	dr	date	title
D				H/D D-SUB FEMALE STRAIGHT
				scale 2:1
				sheet 2 of 5 size
				10090929 A4
				type PRODUCT_CUSTOMER DRAWING
sheet index	revision sheet			

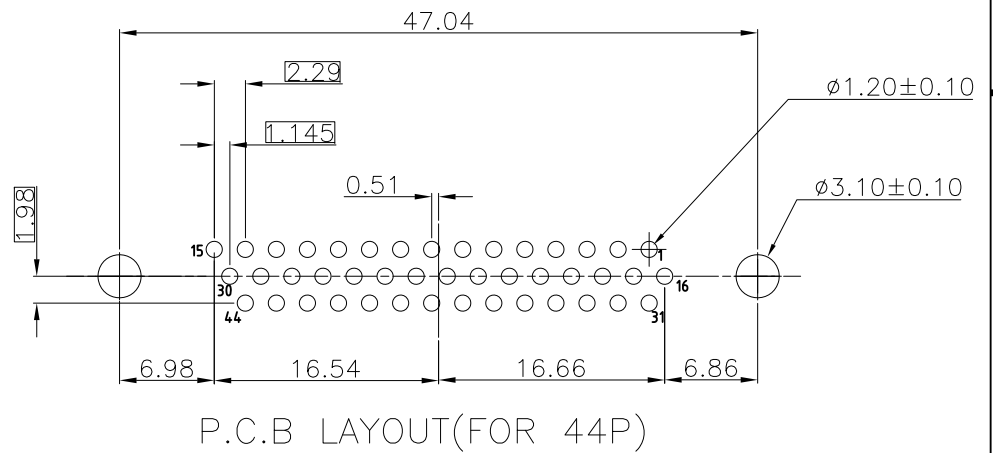
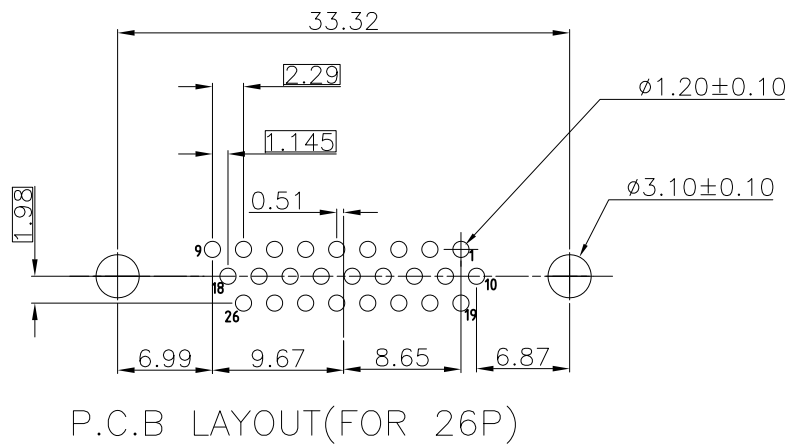
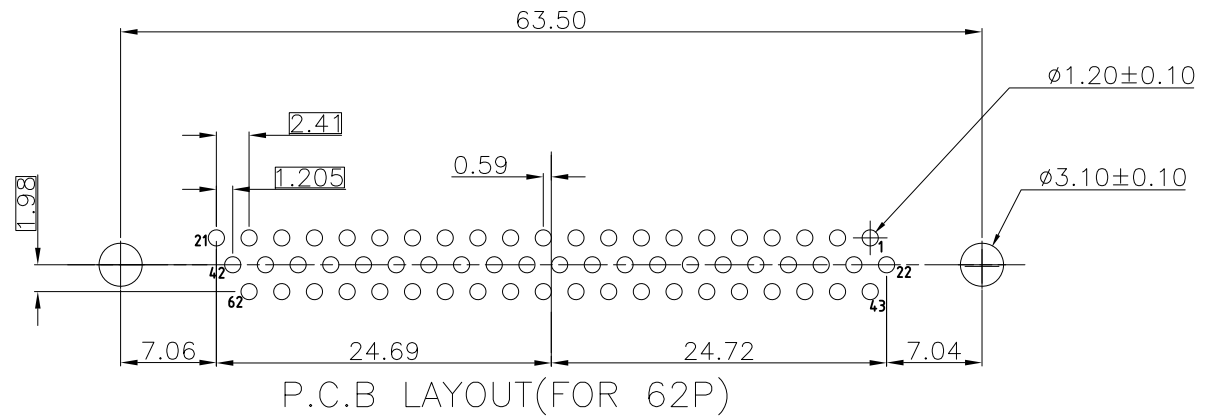
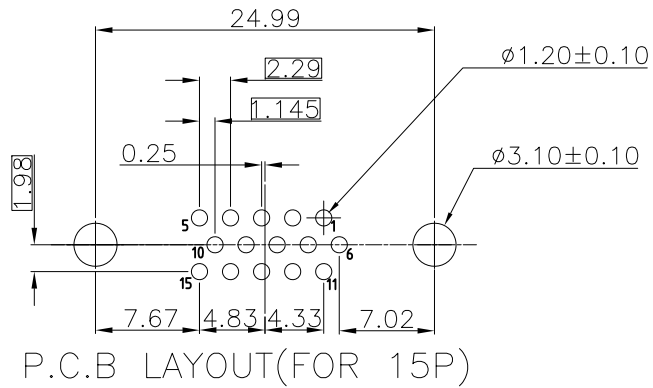

A

A

B

B

mat'l. code		surface		tolerance		projection		product family	
-		ISO 1302		ISO 406 ISO 1101				D-SUB	
ltr		ecn no		dr		date		title	
D								H/D D-SUB FEMALE STRAIGHT	
						MM			
						scale 2:1			
		dr		JASON.HSU		12/10/09		dwg no	
		enr		ALIAS.BABU		2014-07-29		sheet 3 of 5	
		chr		MITHUN.PAUL		2014-07-29		size	
		appd		BIJU.K.PAUL		2014-07-29		A4	
sheet index		revision sheet						type	
								PRODUCT_CUSTOMER DRAWING	

5

B

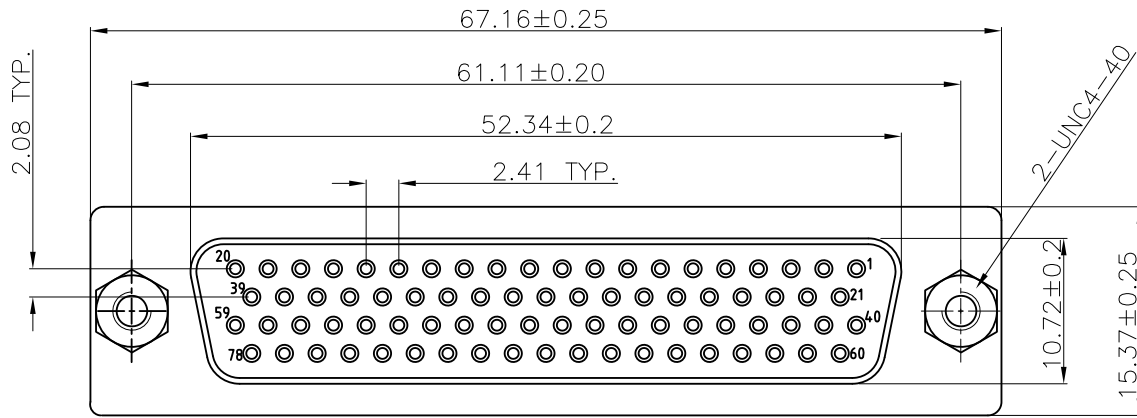

REMARK:

1. CHARACTERISTICS:

RATED VOLTAGE: 250V
 RATED CURRENT: 2.5AMP
 CONTACT RESISTANCE: 35mohms MAX. INITIAL,
 50mohms MAX. AFTER.

INSULATION RESISTANCE: 5000Mohms MIN. at 500V DC
 DIELECTRIC STRENGTH: 750VRMS
 OPERATING TEMPERATURE RANGE: -55° C~105° C
 INSERTION/EXTRACTION FORCE PER CONTACT: 5N Max./0.2N Min.
 MATING/UNMATING CYCLES: 200MATINGS MIN FOR GOLD-FLASH
 500MATINGS MIN FOR 30u" GOLD.

2. MATERIAL:

INSULATORS: THERMOPLASTIC G.F.(UL94V-0) BLACK
 CONTACTS: COPPER ALLOY, GOLD(G/F or 30u") TOP OVER CONTACT
 AREA, 100u" Min MATTE TIN TOP OVER SOLDER AREA,
 50u" Min NICKEL UNDER PLATE.
 SHELL: CARBON STEEL, 100u" Min NICKEL TOP OVER,
 50u" Min COPPER UNDER PLATE.
 HARPOON: COPPER ALLOY, 100u" Min MATTE TIN PLATED.
 NUT: COPPER ALLOY, 50u" Min NICKEL PLATED.

3. PART NUMBER DESCRIPTION:

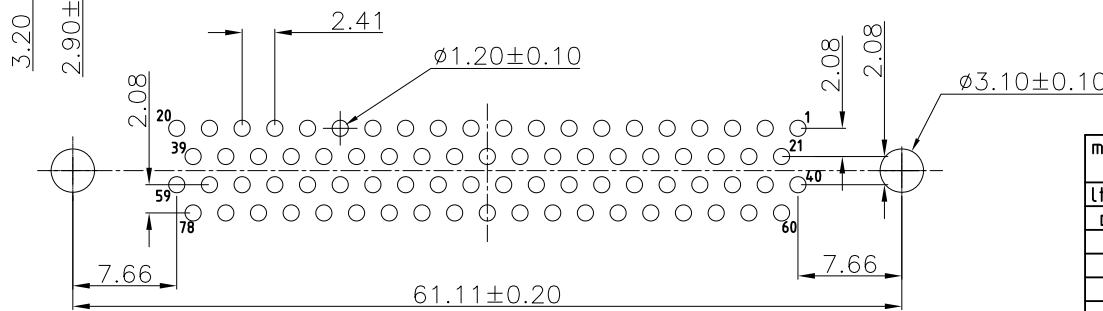
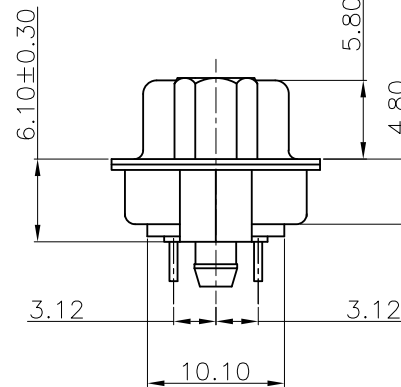
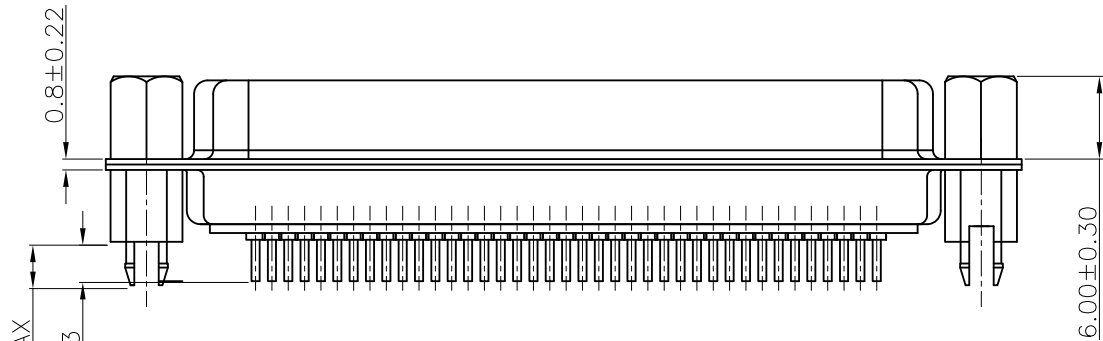
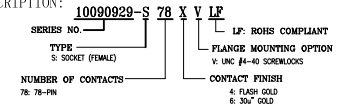

P.C.B LAYOUT

PART NO.: 10090929-S78*VLF

mat'l. code		surface		tolerance		projection		product family	
-		ISO 1302		ISO 406 ISO 1101				D-SUB	
ltr		ecn no		dr		date		title	
D								H/D D-SUB FEMALE STRAIGHT	
						angles		scale 2:1	
						.02 .38		sheet 5 of 5 size	
						.00±.25		10090929 A4	
						0'±2'		type PRODUCT_CUSTOMER DRAWING	
						.000±.010			
		dr		JASON.HSU		12/10/09			
		engr		ALIAS.BABU		2014-07-29			
		chr		MITHUN.PAUL		2014-07-29			
		appd		BIJU.K.PAUL		2014-07-29			
sheet index		revision sheet							