

bright ideas

e2v technologies ltd  
Waterhouse Lane  
Chelmsford  
Essex CM1 2QU  
United Kingdom  
T +44 (0)1245 493 493  
F +44 (0)1245 492 492

e2v technologies ltd  
Carholme Road  
Lincoln  
LN1 1SF  
T +44 (0) 1522 526 352  
F +44 (0) 1522 545 140

USA  
e2v technologies inc  
4 Westchester Plaza  
Elmsford  
NY 10523-1482  
T +1 914 592 6050  
F +1 914 592 5148

France  
e2v technologies sas  
16 Burospace  
F-91 572 Bievres Cedex  
T +33 (0) 1 6019 5500  
F +33 (0) 1 6019 5529

Germany  
e2v technologies gmbh  
Industriestraße 29  
82194 Gröbenzell  
T +49 (0) 8142 41057-22  
F +49 (0) 8142 284 547

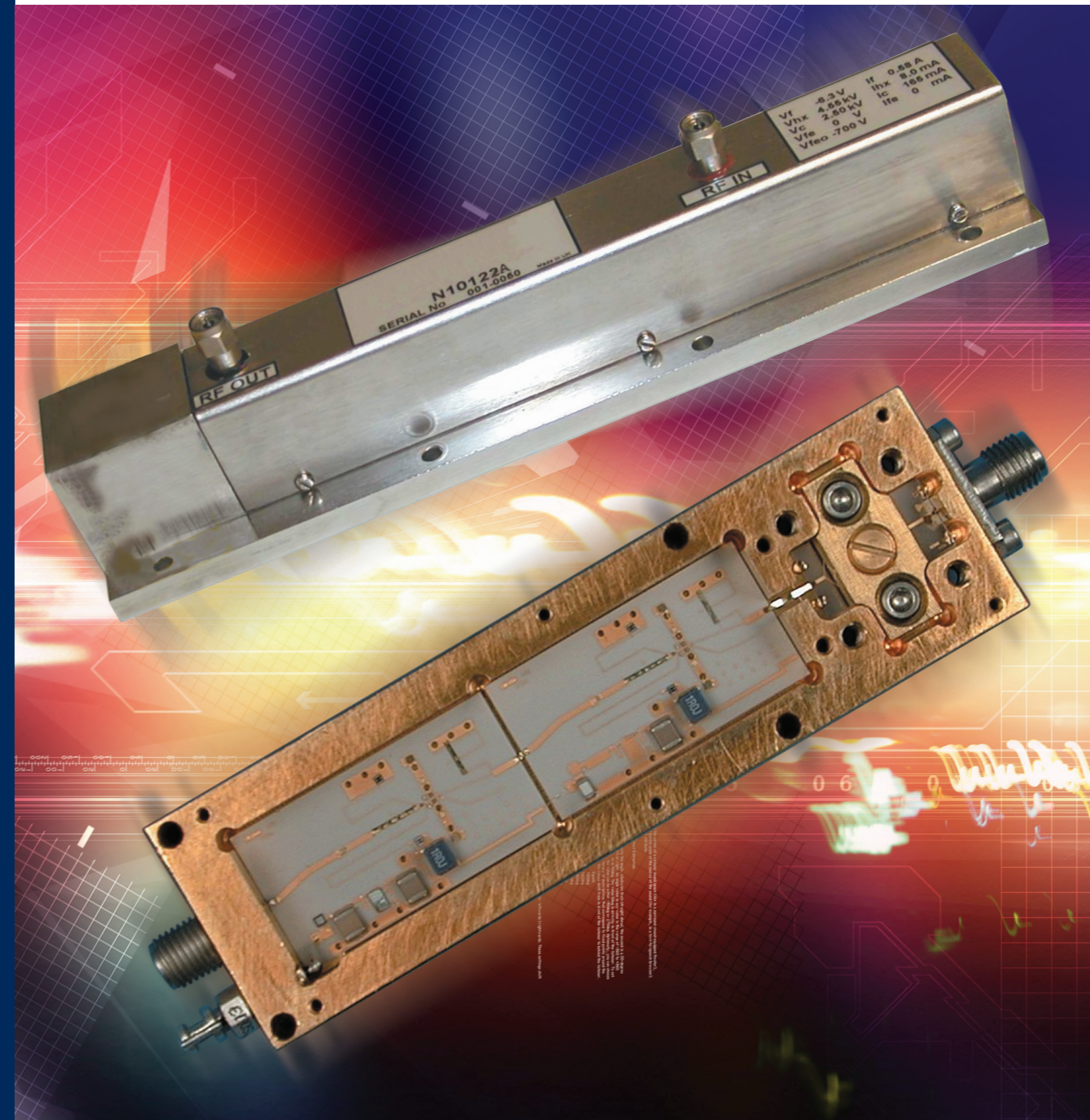

## MICROWAVE PRODUCT GUIDE

Contents	Page
Solid-State Introduction	2
New product developments	3
High Power Solid-State Receiver Protectors	4
Passive Limiters	5
Low Noise Front Ends, noise generators	8
Ferrite Devices, Circulators and Isolators	9
Performance Monitors	13
Mixers	14
Microstrip Control Components, Surface Mount Limiters	15
Amplifier Modules	16
Coil Pre-amplifiers for MRI	17
Integrated Microwave Packages	18
Circuits	22
Microwave semiconductors	23
Electronic Safety and Arming	31
Free Electron Technologies (FET)	33
Linear Accelerator Magnetrons	34
CW Magnetrons	35
Pulse Magnetrons	36
Injection Locked Magnetrons	39
Broadband CW Travelling Wave Tubes	40
Pulsed Travelling Wave Tubes	41
Travelling Wave Tubes for Satellite Ground Stations and Terrestrial Communications	42

This Short-form Catalogue provides the key performance characteristics of Microwave and Solid-State Products made by e2v technologies limited. Customers are invited to contact the Sales Office for further information.

Enquiries for special products not included in this guide are welcome.

e2v technologies ltd  
Waterhouse Lane  
Chelmsford  
Essex CM1 2QU  
United Kingdom  
T +44 (0)1245 493 493  
F +44 (0)1245 492 492  
www.e2vtechnologies.com

e2v technologies ltd  
Carholme Road  
Lincoln  
LN1 1SF  
T +44 (0) 1522 526 352  
F +44 (0) 1522 545 140  
www.e2vtechnologies.com

**Disclaimer:** The part numbers used in this guide are for reference purposes only and in no way an indication or offer by e2v to manufacture, sell or otherwise make available any products, information or other documentation. e2v will not be responsible for any reliance based on this information or the contents of this guide. The contents are subject to change without notification.

## SOLID-STATE INTRODUCTION

Since its foundation in 1947, e2v technologies has been recognised and respected for pioneering new developments in RF and Microwave technology. Within the solid-state microwave and electronics operation, this respect continues as customers choose e2v technologies' products and engineering skills to meet ever more demanding technological challenges for tomorrow's applications.

Today's solid-state microwave and electronics operation provides a wide range of microwave and electronic components and sub-systems to markets including Defence, Marine, Civil Airborne, Communications, Medical and most recently Automotive. The product range can be split into three groups:

### MICROWAVE DEVICES

- Voltage Controlled Oscillators
- Amplifiers and Modules
- Receiver Protectors
- Circulators and Isolators
- Mixers
- Low Noise Front Ends

### MICROWAVE AND ELECTRONIC SUB-SYSTEMS

- Electronic Safety and Arming Units
- Radar Performance Monitors
- Integrated Microwave Packages

### MICROWAVE COMPONENTS

- GaAs Gunn Diodes
- GaAs and Silicon Schottky Diodes
- GaAs Varactor Diodes
- Silicon PIN Diodes
- Thick and Thin Film Circuits

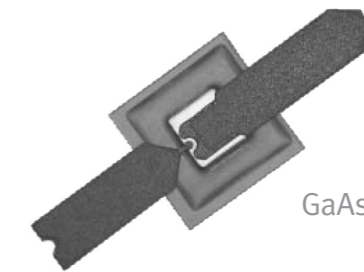

GaAs Schottky Diode

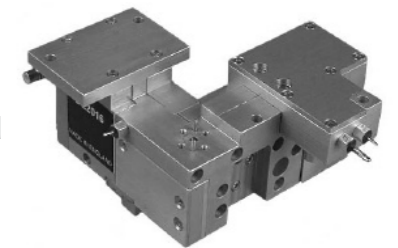

94GHz Radar Head



X-band Low Noise Front End

Product design is supported by an extensive suite of CAD systems including:

- **Ansoft DESIGNER and HFSS** – Microwave circuit design
- **AUTOCAD INVENTOR and Pro-ENGINEER** – Mechanical design
- **ANSYS** – Thermal and mechanical modelling
- **ITEM TOOLKIT** – Reliability analysis including MTBF, FMEA and FTA
- **MINITAB** – Statistical data analysis tool
- **ORCAD** – Low frequency circuit design
- **SEETRAX** – PCB layout

Solid-state microwave and electronic devices form the essential technology building blocks for the systems in use today. Building upon its heritage and experience, e2v technologies aims to deliver solutions for tomorrow.

## NEW PRODUCT DEVELOPMENTS

A rolling programme of new product and technology development is underway at e2v technologies; the key aspects of this programme are presently within the following technology areas:

- Updated LNA Design Library for Defence Applications**  
 Expansion of the e2v library of LNA designs for future business requirements.
- 50kW Ka-Band Limiter for Airborne Defence Applications**  
 Development of a basic high-power ka-band Solid State limiter, to replace TR Cells operating in this frequency band.
- EW Design Library**  
 Development of the e2v library of basic micro-strip limiter and switch designs operating over a broad bandwidth (2-6GHz and 6-18GHz) for Electronic Warfare applications.
- Low energy EFI Development**  
 Development of an EFI with a threshold energy of <math>\lt;0.1</math> and an operating voltage of <math>\lt;1000\text{V}</math>

### Ku-Band Solid-State Limiter

Solid-State Ku-Band Receiver Protector incorporating a stepped 30dB Sensitivity Time Control (S.T.C.) Attenuation function, phase matching and noise source.

Compact Size: only 35mm long  
 Frequency: 16.6 to 17.0 GHz  
 Insertion Loss: 1.35 dB max.  
 VSWR: 1.4:1  
 STC: 0 – 30 dB, current controlled  
 Noise Source: 14 dBENR min.

RF Input Power: 10kW Peak  
 Pulse Width: 1 Fsec @0.1% duty

Flat Leakage: 100 mW max.  
 Spike Leakage: 1 W max.  
 Recovery: 1Fsec. max.

Operating Temperature: -25°C to +70°C

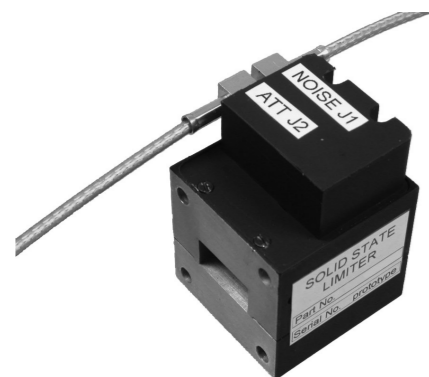

Ku-Band Solid-State Limiter

- Updated Receiver Protector/Isolator Design Library for Missile Seeker Applications**  
 Further development of the e2v Limiter design portfolio, focused on new Seeker applications. Two new Limiter designs within this area are described below.

The operation occupies over 100,000 square feet and is located near the centre of the city of Lincoln, 150 miles from London in the UK. With capabilities ranging from DC to >100 GHz, e2v technologies offers both a range of standard products and high quality design and development capabilities.

With an engineering base of degree-qualified Engineers and Scientists and quality approval to both ISO9001:2000 and TS/ISO16949 (automotive product lines only), e2v technologies ensures that all products are designed, developed and manufactured to the highest standards.

### Ku-Band Passive Limiter

Compact Size: 16mm long x 16mm high x 20mm wide  
 Reduced Height Waveguide

50W Peak Input Power  
 High Duty Ratio: 40%

Spike / Flat Leakage: 15dBm max.  
 Recovery: 100 nsec. max.

Insertion Loss: 1.0dB max.  
 VSWR: 1.3:1

Operating Temperature: -45°C to +105°C



Ku-Band Passive Limiter

## HIGH POWER SOLID-STATE RECEIVER PROTECTION

e2v technologies manufactures a broad range of solid-state receiver protectors in all radar frequency bands between 1.25 and 40 GHz. The high power waveguide devices specified below are divided into two categories:

- Solid-state receiver protectors that normally require synchronous bias during transmission; additional passive protection can often be included
  - Passive limiters that require no external bias
- PIN switches can be supplied:
- with or without electronic drive circuit
  - with or without built-in test (BIT)
  - with quasi-active circuits for interpulse protection
  - with pre-TR tubes for high peak power fault conditions

- with phase and amplitude matching.
- All solid-state receiver protectors can be supplied with the following options:
- Additional filtering to attenuate spurious transmissions or extend protection range.
  - Precision dynamic attenuation (STC), digital or analogue
  - Solid-state noise generators for inter-pulse performance monitoring.

The following specifications are typical:

## SOLID-STATE RECEIVER PROTECTORS - REQUIRING SYNCHRONOUS BIAS DURING TRANSMISSION

Frequency band	Type	Band-width (MHz)	Active ratings		Passive ratings		Flat leakage (mW)	Spike leakage (mW)	Insertion loss (dB)	Recovery to -1 dB (µs)	
			Peak power (kW)	Duty cycle (%)	Peak power (kW)	Duty cycle (%)					
L-Band	B3SS06081	150	40	10	5.0	10	100	100	1.35:1	0.4	3.0
S-Band	B3SS10031	400	2.5	3.6	1.0	3.6	100	1000	1.4:1	0.8	5.0
S-Band	B3LT10051	400	26	6.0	3.0	6.0	50	1000	1.4:1	0.6	20
S-Band	B3SS10121	300	70	3.1	7.0	3.1	50	1000	1.4:1	0.6	10
X-Band	B3SS16171	500	0.5	3.0	0.01	3.0	40	100	1.3:1	1.0	1.0
X-Band	B3SS16221	500	3.0	30	0.3	1.0	50	100	1.3:1	0.8	0.2
X-Band	B3SS16151	500	5.0	2.0	0.01	2.0	50	100	1.4:1	1.0	0.2
X-Band	B3SS16201	400	5.0	3.6	0.3	3.6	20	100	1.4:1	0.8	1.0
X-Band	B3SS16241	600	5.0	10	0.01	CW	50	100	1.4:1	0.7	0.1
X-Band	B3SS16271	400	7.5	2.5	0.5	20	35	150	1.3:1	0.7	0.3
X-Band	B3SS16341	500	2.0	10	16	0.1	50	500	1.4:1	0.95	1.0
X-Band	B3SS16261	500	10	3.0	1.0	3.0	50	200	1.4:1	0.8	0.2
X-Band	B3SS16351	500	55	0.1	3.0	2.5	50	500	1.4:1	0.8	1.0
X-Band	B3SS16321	1500	7.5	2.5	0.3	3.6	50	200	1.5:1	1.8	0.5
Ku-Band	B3SS18101	600	0.8	4.7	0.1	4.7	100	200	1.4:1	1.0	2.0
Ku-Band	B3SS18031	1000	1.4	4.0	0.35	4.0	100	200	1.4:1	1.3	0.8
Ka-Band	B3SS22071	500	0.08	25	0	0	10	0	1.4:1	2.0	0.1
Ka-Band	B3SS22031	1000	0.16	12	0	0	75	0	1.4:1	1.6	0.6
Ka-Band	BS206711	2500	0.6	4.0	0.1	0.01	50	10,000	1.4:1	1.35	0.4
Ka-Band	B3SS22111	1000	1.5	1.0	0.05	6.0	50	200	1.4:1	3.0	1.0
Ka-Band	B3SS22081	500	2.0	0.1	0	0	200	0	1.4:1	0.8	0.2
Ka-Band	B3SS22121	400	50	0.1	0.05	0.1	35	100	1.4:1	1.3	1.0

## PASSIVE LIMITERS — STANDARD

Frequency range (MHz)	Type	Peak power (kW)	Total leakage (mW)	Return loss (dB)	Insertion loss (dB)	Recovery		Length (mm)	Flanges (see page 6)
						period to -3 dB (μs)	S.T.C. attenuation (dB)		
3020 — 3080	<b>B3LT1006</b>	30	50	20	1.0	1.0	—	55	SF
3020 — 3080	<b>B3LT1007</b>	30	50	20	1.0	1.0	30 <sup>[1]</sup>	55	SF
3020 — 3080	<b>B3LT1008</b>	30	100	20	1.0	1.0	30	55	SF
3020 — 3080	<b>B3LT1009</b>	30	100	20	1.0	1.0	30	55	SF
3020 — 3080	<b>B3LT1018</b>	30	100	18	1.0	1.0	25 <sup>[2]</sup>	55	SF
3020 — 3080	<b>B3LT1014</b>	30	50	18	1.0	1.0	—	74	SG
3030 — 3070	<b>BS169</b>	25 <sup>[3]</sup>	50	15.0	0.5	—	—	32.9	SE/SD
3030 — 3070	<b>B3LT1069</b>	25 <sup>[3]</sup>	50	15.0	0.5	—	—	32.9	SE
8800 — 9000	<b>B3LT16104</b>	30	100	20	1.0	1.3	—	44	XA
8800 — 9000	<b>B3LT16124</b>	30	100	20	1.0	1.3	30	44	XA
9100 — 9300	<b>B3LT1694</b> <sup>[6]</sup>	25	100	18	1.0	1.3	50 <sup>[4]</sup>	54	XA
9300 — 9500	<b>B3LT1616</b>	10	1000	16	0.5	1.0	—	9	XA
9300 — 9500	<b>B3LT1610</b>	10	100	14	1.0	1.0	—	35	XA
9300 — 9420	<b>B3LT1686</b>	12 <sup>[5]</sup>	100	16	0.8	1.3	—	27	XA
9300 — 9500	<b>B3LT16114</b>	50	100	20	1.3	1.3	—	44	XA
9300 — 9500	<b>B3LT16114A</b>	60	100	20	1.3	1.3	—	44	XA/XC
9300 — 9500	<b>B3LT16125</b>	70	100	20	1.8	1.5	—	44	XA/XC
9300 — 9500	<b>B3LT1695</b> <sup>[6]</sup>	25	100	18	1.0	1.3	50 <sup>[4]</sup>	54	XA
9320 — 9430	<b>B3LT1658</b>	12 <sup>[5]</sup>	100	20	1.0	1.3	—	35	XA
9320 — 9430	<b>B3LT1666</b>	12 <sup>[5]</sup>	100	20	1.0	1.3	—	35	XA
9360 — 9460	<b>B3LT1669</b>	10	100	20	1.0	1.0	25 <sup>[2]</sup>	35	XA
9360 — 9460	<b>B3LT1668</b>	25	100	20	1.0	1.3	25 <sup>[2]</sup>	35	XA
9360 — 9460	<b>B3LT1649</b>	30	100	20	1.0	1.3	—	35	XA
9360 — 9460	<b>B3LT1654</b>	30	100	20	1.0	1.3	30	35	XA
9360 — 9460	<b>B3LT1660</b>	30	100	20	1.0	1.3	30	35	XA
9690 — 9790	<b>B3LT16113</b>	50	100	20	1.3	1.3	—	44	XA/XC
9380 — 9570	<b>B3LT16122</b>	70	100	20	1.3	1.3	—	44	XA/XC

Integral filter for pi-1 attenuation included on most options, duty factor 0.001 typical.



Active receiver protector



Passive Receiver protector

[1] For each of two diodes

[3] When used with BS894 TR tube

[5] Pulse duration 5 μs

[2] Integrated STC generator circuit

[4] Sum of two separately biased diodes

[6] Includes 16 dB ENR noise source

## PASSIVE LIMITERS - HIGH MEAN POWER

Frequency band	Type	Band-width (MHz)	Fault ratings		Normal operation				Insertion loss (dB)	Recovery to -1 dB (μs)	
			Peak power (kW)	Duty cycle (%)	Peak power (kW)	Duty cycle (%)	Flat leakage (mW)	Spike leakage (nJ)			VSWR
S-Band	<b>B3LT10201</b>	200	20	1 pulse	2.0	10.8	50	1000	1.4:1	0.5	1.2
S-Band	<b>B3LT10171</b>	300	20	1 pulse	2.5	10	100	500	1.4:1	0.5	3
S-Band	<b>B3LT10121</b>	300	25	10	2.5	10	100	500	1.4:1	0.6	5.0
S-Band	<b>B3LT10111</b>	200	30	10	5	10	100	1000	1.4:1	0.5	10
S-Band	<b>B3PL10081</b>	300	60	10	6.0	1.0	50	250	1.4:1	0.4	5.0
S-Band	<b>B3LT10221</b>	400	2.5	4	2.5	4	400	5.0	1.5:1	0.8	2.0
C-Band	<b>B3LT12011</b>	300	10	2.0	800	2.5	50	100 mW	1.25:1	0.5	0.5
C-Band	<b>B3LT12021</b>	600	3	10	300	10	30	100 mW	1.3:1	0.7	0.8
X-Band	<b>B3LT16731</b>	400	0.4	2.5	0.25	2.5	30	100 mW	1.4:1	0.6	0.3
X-Band	<b>B3LT16651</b>	600	2.5	2.0	0.3	4.0	50	5.0	1.4:1	0.6	1.0
X-Band	<b>B3LT161081</b>	850	3.0	2.0	0.12	10	50	2.0	1.4:1	0.6	0.8
X-Band	<b>B3LT16381</b>	500	5.0	0.1	0.5	5.0	50	10	1.4:1	0.8	1.0
X-Band	<b>B3LT16551</b>	500	5.0	1.0	0.5	10	50	250 mW	1.4:1	0.9	0.7
X-Band	<b>B3LT16341</b>	500	8.0	1.0	8.0	1.0	1.0	2.0	1.4:1	0.75	1.0
X-Band	<b>B3LT16631</b>	500	10	0.1	1.5	2.0	30	2.0	1.4:1	0.6	1.0
X-Band	<b>B3PL16121</b>	500	50	1.0	15	0.1	50	500 mW	1.4:1	0.8	0.8
Ku-Band	<b>B3LT18181</b>	300	0.05	25	0.05	25	30	0.5	1.4:1	1.0	0.05
Ku-Band	<b>B3LT18041</b>	500	0.37	1.4	0.37	1.4	40	4.0	1.4:1	0.8	0.4
Ku-Band	<b>B3LT18031</b>	2000	0.35	4.0	0.35	4.0	100	4.0	1.4:1	1.3	0.8
Ku-Band	<b>B3PL18001</b>	2000	5.0	0.1	5.0	0.1	70	200 mW	1.5:1	1.3	0.5
Ku-Band	<b>B3LT18111</b>	300	10	0.1	2	0.1	50	1000 mW	1.4:1	1.35	1.0
Ku-Band	<b>B3LT18121</b>	1200	0.5	10	0.05	10	50	500 mW	1.4:1	1.2	1.0
Ka-Band	<b>BS20781</b>	1000	00.05	4.0	.05	4.0	50	4.0	1.4:1	1.5	1.0

## COAXIAL LIMITERS

L-Band	<b>B3LT98011</b>	200	—	—	2.0	7.0	15	50 mW	1.25:1	0.5	2.0
S-Band	<b>B3LT98031</b>	300	—	—	0.1	10	100	1.0 W	1.4:1	0.3	10
S-Band	<b>B3LT98041</b>	200	—	—	0.25	10	80	1.0 W	1.25:1	0.3	3.0

## PRE-TR + COAXIAL LIMITERS

L-Band	<b>B3LT06051</b>	100	60	10.4	15	10.4	50	1.5 W	1.4:1	0.6	5.0
L-Band	<b>B3LT06041</b>	200	158	3.8	17.7	3.8	50	1.0 W	1.4:1	0.4	7.0
L-Band	<b>B3LT06031</b>	200	200	7.1	21	7.1	50	1.0 W	1.4:1	0.5	7.0



Ku-Band Rugged Passive Limiter

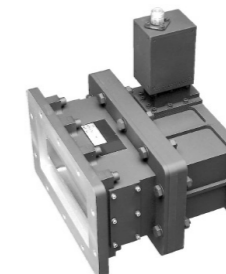

L-Band Pre-TR and Coaxial Limiter

## FLANGES

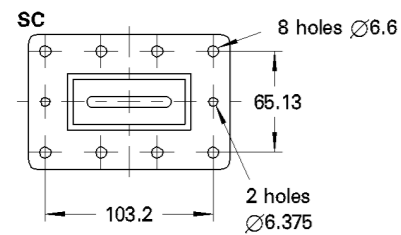
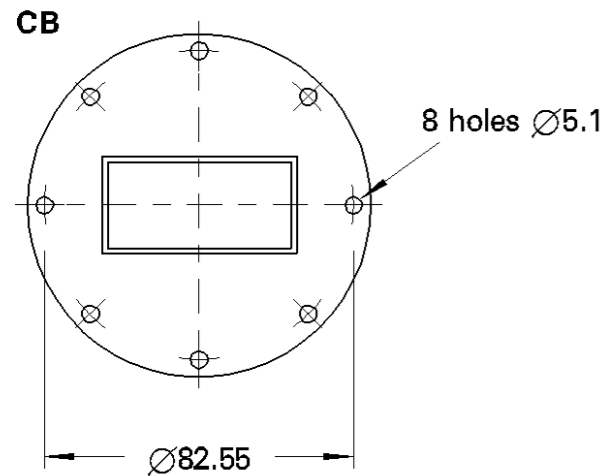

**SD** as SC but with 8 holes  $\varnothing 7.3$  and 2 dowels  $\varnothing 6.2$

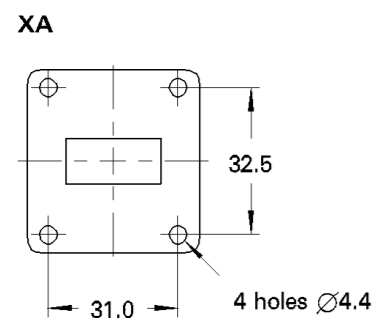
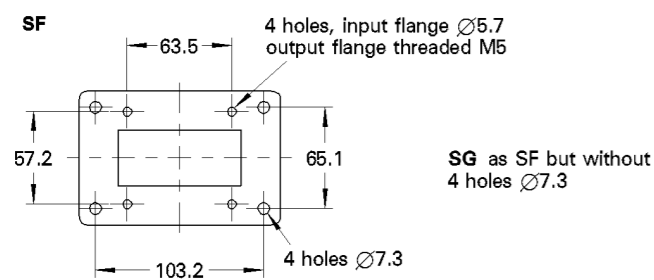
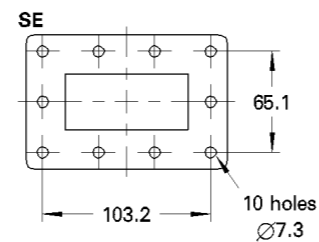

**XB** as XA but with 4 holes 8-32 UNC

**XC** as XA but with 4 holes M4 x 0.7

## LOW NOISE FRONT ENDS

A range of low noise front end down-converters is available, covering the S- and X-band frequency ranges. Basic functions can be adapted to suit individual needs, as can the mechanical package outline.



X-band Low Noise Front End

Frequency (GHz)	Type	Details	Gain (dB min)	Noise figure (dB max)	Power Supplies
3.02–3.08	<b>B7RX1001</b>	IF output BNC female, filtered power supplies	6.0	3.0	+12 V, $V_t$ 4 – 24 V
3.02–3.08	<b>B7RX1002</b>	Feedthrough pin connectors	6.0	3.0	+12 V, $V_t$ 4 – 24 V
3.02–3.08	<b>B7RX1008</b>	IF output BNC female, RF input filter	6.0	3.0	+12 V, $V_t$ 4 – 24 V
9.3–9.5	<b>B3RX1612</b>	PCB edge connector	2.5	3.5	+5 V, $V_t$ 4 – 24 V
9.36–9.46	<b>B3RX1613</b>	Integrated limiter	2.0	4.5	+5 V, $V_t$ 5 – 35 V
9.36–9.46	<b>B3RX1616</b>	Integrated limiter	-7.0	7.5	+5 V, $V_t$ 2 – 11 V
9.36–9.46	<b>B3RX1618</b>	Integrated high power limiter	2.0	5.5	+5 V, $V_t$ 5 – 30 V
9.36–9.46	<b>B3RX1619</b>	Integrated high power limiter	-7.0	7.5	+5 V, $V_t$ 5 – 30 V
9.3–9.5	<b>B3RX1620</b>	PCB edge connector	2.5	3.5	+5 V, $V_t$ 4 – 24 V
9.3–9.5	<b>B3RX1622</b>	PCB edge connector, hermetic seal for airborne use	2.5	3.5	+5 V, $V_t$ 4 – 24 V
9.1–9.3	<b>B3RX1627</b>	PCB edge connector	2.5	3.5	+5 V, $V_t$ 4 – 24 V
9.2–9.3	<b>B3RX1628</b>	PCB edge connector	2.5	3.5	+5 V, $V_t$ 4 – 24 V
8.8–9.0	<b>B3RX1629</b>	PCB edge connector	2.5	3.5	+5 V, $V_t$ 4 – 24 V
9.1–9.3	<b>B3RX1631</b>	PCB edge connector, 100 MHz IF	3.0	3.0	+5 V, $V_t$ 4 – 24 V
9.3–9.5	<b>B3RX1632</b>	PCB edge connector, 100 MHz IF	3.0	3.0	+5 V, $V_t$ 4 – 24 V
9.36–9.46	<b>B3RX1635</b>	Integrated high power limiter	0	6.5	+5 V, $V_t$ 5 – 30 V
9.325–9.475	<b>B3RX1637</b>	Single balanced mixer and electronically tuned LO	-7.0	7.5	+5 V, $V_t$ 4 – 24 V
9.3–9.43	<b>B3RX1639</b>	PCB edge connector	-7.0	7.5	+5 V, $V_t$ 4 – 24 V
9.34–9.48	<b>B3RX1640</b>	PCB edge connector	4.0	2.0	+5 V, $V_t$ 4 – 24 V

## NOISE GENERATORS

A range of solid-state noise generators is available, covering the X-band frequency range. Basic functions can be adapted to suit individual needs, as can the mechanical package outline. Variants for both low and high power RF applications can be supplied. They may also be used as power detectors to provide system performance monitoring.

Frequency (GHz)	Type	Details	ENR (dB max)	Incident power pulsed, 1 $\mu$ s typ (kW max)	Power Supplies
8.8–9.0	<b>B3NG1639</b>	Waveguide (WG16), cal. frequency 8.900 GHz	15.0	60	+21 V, 0 – 25 mA
9.3–9.5	<b>B3NG1640</b>	Waveguide (WG16)	15.0	60	+21 V, 0 – 25 mA
9.3–9.5	<b>B3NG1641</b>	Waveguide (WG16), cal. frequency 9.375 GHz	15.0	60	+21 V, 0 – 25 mA
9.3–9.5	<b>B3NG1642</b>	Waveguide (WG16), cal. frequency 9.410 GHz	15.0	60	+21 V, 0 – 25 mA
34–36	<b>DA9700</b>	Waveguide (WG22)	26	1	+28V, 0 – 10 mA

## FERRITE DEVICES

e2v technologies manufactures Ferrite Devices operating from 350 MHz to 120 GHz, for a wide variety of applications from low cost marine radar to state-of-the-art military devices. Standard units are available in regular waveguide sizes and some special sizes.

e2v technologies offers circulators and isolators as stand-alone units and as part of an integrated microwave package. All come with the assurance that e2v technologies has the facilities to power test units, giving confidence in all devices.

The design and manufacturing facility at Lincoln has an extensive capability and technical knowledge built up for ferrite components. The following is a guide to the range of standard components available.

## WAVEGUIDE JUNCTION CIRCULATORS AND ISOLATORS

Covering most standard waveguide sizes and a few specials in H-Plane, E-Plane and Slimline types.

Typical values are shown; actual values will depend on operating conditions. Match and Isolation are given together with achievable bandwidths. For very wideband devices, the losses will increase due to isolation loss.

Junction Isolators are circulators with a built-in termination.

## PHASE SHIFT CIRCULATORS

Capable of significant high power, phase shift circulators provide the heavyweight end of ferrite device operation. Bandwidth limitations are primarily due to the Tee and Coupler, though extended performances can be achieved. Out-of-band requirements should be stated with enquiries.

## STANDARD CIRCULATORS

Frequency range (MHz)	Type	Peak power (kW)	Mean power (W)	Isolation (dB)	Insertion loss max (dB)	
3030-3070	<b>B3JC1007</b>	30	3	20	0.3	Coax output available
9300-9500	<b>B3JC1647</b>	4.0	0.04	20	0.4	
9300-9500	<b>B3JC1648</b>	10	1	20	0.4	
9300-9500	<b>B3JC1649</b>	30	3	20	0.4	
Ku-Band	<b>B3JC18271</b>	400	100	20	0.35	
Ka-Band	<b>BSJC2202</b>	10	5	20	0.4	

## COAXIAL CIRCULATORS

An extensive range is available, for frequencies from 400 MHz to 18 GHz

## RESONANCE ISOLATORS

High power capabilities in the range 1.2 GHz to 6.4 GHz, at up to 5 MW peak power

## MICROSTRIP AND STRIPLINE CAPABILITIES

e2v technologies has in-house facilities for circuit preparation using thick and thin film techniques on ferrite and garnet substrates, with a large range of proven devices. e2v technologies can design circuits for your application or print your design on the required substrate materials.



Ka-Band Phase Shift Circulator

## F SERIES HIGH POWER WAVEGUIDE DEVICES

Device	Type	Freq GHz		Bandwidth MHz	Insertion dB	Isolation dB	Power		Remarks
		From	To				Peak	Mean	
F1003-33	<b>Water cooled isolator &amp; separate water load</b>	2.425	2.475	50	0.2	19		6KW	Standard band
F1003-34		2.425	2.475	50	0.2	19		6KW	As -33, alternative mounting position
F1003-43		2.350	2.400	50	0.2	19		6KW	Eastern European band
F1003-44	<b>Water cooled isolator &amp; integral water load</b>	2.350	2.400	50	0.2	19		6KW	As -43, alternative mounting position
F1003-35		2.425	2.475	50	0.2	20	9.0KW	6KW	Integral casting isolator
F1003-36		2.425	2.475	50	0.2	20	9.0KW	6KW	As -35, alternative mounting position
F1003-37	<b>WG 10 resonance isolator</b>	2.425	2.475	50	0.2	20	9.0KW	6KW	As -36, with reverse circulation
F1004-60		2.852	2.861	0.6	27	5.0MW	3.0KW	Several alternatives available	
F1151-02	<b>WG 8 air cooled circulator</b>	2.0	2.3	300	0.3	21		2.0Kw	Machined casting
F1152-01	<b>WG 9A air cooled circulator</b>	2.35	2.7	350	0.25	22		1.0Kw	Machined casting
F1152-52	<b>WG 4 Water cooled circulator</b>	0.894	0.898	4	0.2	18		60KW	British frequency band
F1152-53		0.913	0.917	4	0.2	18		60KW	European frequency band
F1152-62		0.894	0.898	4	0.2	18		60KW	British frequency band
F1152-63		0.913	0.917	4	0.2	18		60KW	European frequency band
F1154-01	<b>Air cooled circ</b>	5.4	5.9	500	0.2	20	375W	20KW	R48 round flanges
F1154-04	<b>Air cooled circ</b>	4.4	5.0	600	0.2	20	1KW	1KW	
F1154-05	<b>Air cooled circ</b>	4.4	5.0	600	0.2	20	3KW	3KW	
F1157-02	<b>Air cooled circ</b>	8.6	9.2	600	0.3	21	300	200KW	Flanges drilled to UBR84
F1158-02	<b>Air cooled circ</b>	8.6	10	1400	0.25	19	500	60KW	WG 16 flanger to UBR100
F1158-07	<b>Air cooled circ</b>	8.5	9.6	1100	0.25	21			

## F SERIES SLIMLINE ISOLATOR DEVICES

Device	Type	Freq GHz		Bandwidth MHz	Insertion dB	Isolation dB	Power		Remarks
		From	To				Peak	Mean	
(Some designs in WG 14 and WG 15 - contact engineering)									
F1116-01	<b>WG 16</b>	8.4	12.1	100	0.4	35		2	Some specials also available
F1116-02		8.4	12.1	200	0.4	30		2	
F1116-03		8.4	12.1	300	0.4	25		2	
F1116-04		8.4	12.1	400	0.5	23		2	
F1117-01	<b>WG17</b>	10.0	15.0	100	0.4	30		2	Some specials also available
F1117-02		10.0	15.0	200	0.4	25		2	
F1117-03		10.0	15.0	300	0.4	20		2	
F1118-01	<b>WG18</b>	12.4	18.0	100	0.4	30		2	Some specials also available
F1118-02		12.4	18.0	200	0.4	25		2	
F1118-03		12.4	18.0	300	0.4	20		2	

## F SERIES COAXIAL DEVICES

Device	Type	Freq GHz		Bandwidth MHz	Insertion dB	Isolation dB	Power		Remarks
		From	To				Peak	Mean	
F1020-42	<b>Miniature coaxial X band Iso/circ</b>	7.0	12.5	5500	1.0	15.0		5	Large range of frequency/ SMA connector options available
F1020-43		8.5	9.6	1100	0.4	20.0		5	
F1020-44		7.2	10.8	3600	0.6	17.0		5	
F1020-49		11.0	11.5	500	0.5	25.0		5	
F1032-50	<b>Circ</b>	2.30	2.40	100				200	
F1092-40	<b>Circ</b>	0.82	0.875	55	0.35	20		5	Various connector and load options available
F1092-50		0.905	0.96	55	0.35	20		5	
F1085-10	<b>Circ</b>	4.4	5.0	600	0.3	20	1KW	25 into 2:1	Type N connectors
F1085-12		3.5	5.0	1500					Isolator variants possible
F1096-10	<b>Coaxial Iso / Circ</b>	8.2	8.75	550	0.3	20		5	Various connector and load options available
F1096-22		8.5	9.6	1100	0.3	20		5	
F1096-24		9.1	10.0	900	0.3	20		5	
F1096-25		9.05	9.6	550	0.3	20		5	
F1096-41		11.0	11.5	500	0.5	25		5	
F6*12	<b>Coaxial Iso / Circ</b>	0.3	0.6						Second digit denotes SMA or type N connectors ( 1 = SMA, 2 = N ). Followed by connector / load code eg FFF = 3 female connectors. MFL1= male, female, 1Watt load on ports 1,2,3 respectively. Use L10 for 10 Watt load. 1 Watt or 10 Watt load options. Many frequency and bandwidth options available.
F6*13		0.6	0.8						
F6*14		0.8	1.3						
F6*15		1.3	2.1						
F6*16		2.1	3.0	Large selection of frequencies & bandwidths available					
F6*17		3.0	4.0						
F6*18		4.0	6.0						
F6*19		6.0	8.0						
F6*20		8.0	12.4						

## F SERIES 4 PORT PHASE SHIFT DEVICES

Device	Type	Freq GHz		Bandwidth MHz	Insertion dB	Isolation dB	Power		Remarks
		From	To				Peak	Mean	
F1052-03	<b>Air cooled</b>	2.70	3.10	400	0.5	25 / 23	1.0MW	1.5KW	See `Sundries` for F1230 series of diversion assemblies
F1052-17	<b>Water cooled</b>	2.70	3.10	400	0.6	25 / 23	2.5MW	4.0KW	
F1052-28	<b>Water cooled</b>	2.715	2.915	200	0.3	20	4.5Mw	10Kw	
F1055-22	<b>4 port AC</b>	34	34.4	400	0.6	23	5KW	0.5KW	
F1053-02	<b>4 port AC</b>	13.4	14.0	600	0.4	20	350W	350W	
F1054-08	<b>4 port AC</b>	5.4	5.9	500	0.5	21	80KW	1.6KW	
F1057-01	<b>4 port AC</b>	8.5	9.3	800	0.5	25	300KW	300W	

## F SERIES LOW POWER WAVEGUIDE DEVICES

Device	Type	Freq GHz		Bandwidth MHz	Insertion dB	Isolation dB	Power		Remarks	MOQ
		From	To				Peak	Mean		
F1013-10	WG 16	7.75	8.5	750	0.2	25.0		25	F1045 series + load.	↗
F1013-21	Iso/Circ	8.2	8.8	600	0.2	25.0		25	Several variants available.	
F1013-07		7.9	8.5	600	0.2	30.0		25	Load on any point.	
F1015-22		8.2	10.0	1800	0.3	23		50		
F1015-23	WG 16	8.2	10.2	2000	0.4	23		50	F1046 series +	↗
F1015-24	Iso/Circ	9.2	11.2	2000	0.4	23		50	2 watt load.	
F1015-25		10.4	12.4	2000	0.4	23		50	Load on any port.	
F1015-26		8.2	12.4	4000	0.5	20		25		
F1015-32		8.2	10.0	1800	0.3	23		50		
F1015-33	WG 16	8.2	10.2	2000	0.4	23		50	F1046 series +	↗
F1015-34	Iso/Circ	9.2	11.2	2000	0.4	23		50	10 watt load.	
F1015-35		10.4	12.4	2000	0.4	23		50	Load on any port.	
F1015-36		8.2	12.4	4000	0.5	20		25		
F1047-02		12.25	13.25	1000	0.25	23		20		
F1047-03	WG 17	10.7	11.7	1000	0.2	26		200		
F1047-04	circulator	11.7	12.5	1200	0.2	26		20		
F1047-05		12.5	13.5	1000	0.2	26		200		
F1047-06		14.0	14.5	500	0.2	26		200		
F1048-33		12.4	14.2	1800	0.4	20		10	Other Frequencies available.	
F1048-34	WG 18	14.2	16.0	2800	0.4	20		10	Isolator versions also available	
F1048-35	circulator	16.0	18.0	2000	0.4	20		10	(F1017 series)	
F1048-36		12.4	18.0	5600	0.4	20		10		
F1019-22	WG 22	27.5	29	1500	0.3	20		5	Other Frequency variants available.	
F1019-34	isolator	33.35	34.35	1000	0.5	25		5	All F1019s available in various flange options and as isolators (F1049 series)	
F1019-44	circulator	33.3	36.45	3150	0.45	20		5		
F1019-21	WG 22	26.5	40.0	1000	0.5	28.0		5	Circulator versions F1049-21 & 22	
F1019-22	Iso/Circ	26.5	40.0	2000	0.5	23.0		5	Customer to specify centre frequency	

## PERFORMANCE MONITORS

Radar transceiver performance monitors for use on S- or X-band installations, providing a means of detecting system degradation. A requirement for some marine radar installations.

Frequency (GHz)	Type	Other equipment	Description
S-Band	<b>B3RX10111</b>	None	Performance monitor for use as a transponder on S-band transceiver systems. Generates four pulses at different power levels delayed 100 $\mu$ s after an applied trigger. Power levels can be made to track transmitted magnetron power or stay at a fixed level by a mode select. Inhibit function disables output power. Device uses an internal closed loop circuit to track power variations.
S-Band	<b>B3RX10121</b>	None	Performance monitor for use as a transponder on S-band transceiver systems. Generates two pulses at different power levels delayed 200 $\mu$ s after an applied trigger. Power levels track incident magnetron power. AFC function locks output to magnetron frequency. Device uses an internal closed loop circuit to track power variations.
X-Band	<b>B3RX16261</b>	None	Performance monitor for use as a transponder on X-band transceiver systems. Generates two pulses at different power levels delayed 200 $\mu$ s after an applied trigger. Power levels track incident magnetron power. AFC function locks output to magnetron frequency. Device uses an internal closed loop circuit to track power variations.
X-Band	<b>B3RX16331</b>	None	Performance monitor for use as a transponder on S-band transceiver systems. Generates four pulses at different power levels delayed 100 $\mu$ s after an applied trigger. Power levels can be made to track transmitted magnetron power or stay at a fixed level by a mode select. Inhibit function disables output power. Device uses an internal closed loop circuit to track power variations.
X-Band	<b>B3ED99101</b>	B3IM16431 range	Measures transmitted/reflected peak power and receiver noise figure.
X-Band	<b>B3ED99101A</b>	B3IM1618 B3IM1619	Measures transmitted/reflected peak power and receiver noise figure. 100 MHz IF.

## MIXERS

e2v technologies offers an extensive range of standard mixers covering frequencies up to 110 GHz. Waveguide, coaxial, thin and thick film structures are available supplied by e2v's own Silicon and Gallium Arsenide Schottky diode manufacturing facilities. Designs can be customised to meet the most demanding requirements

Operating frequency (GHz)	Type	Intermediate frequency (MHz)	Typical conversion loss (dB)	Conversion gain (dB)	Noise figure (dB)	Description
8.8–9.9	<b>DA1351F</b>	–	6.5	–	–	Balanced mixer
34–36	<b>DA1317</b>	0–100	7.5	–	–	Balanced mixer
35	<b>DA160021</b>	1700	–	20	7.5	Integrated mixer/low-noise amplifier
30.5–35.5	<b>DA1309</b>	70	–	12	11	Balanced mixer with IF pre-amplifier
35.5–35.9	<b>B3RX22011</b>	10–70	–	25	8	Balanced mixer with input low-noise amplifier and IF pre-amplifier
34.5–35.5	<b>B3RX22021</b>	55–85	–	25	5	Image rejection mixer with input low-noise amplifier and IF pre-amplifier

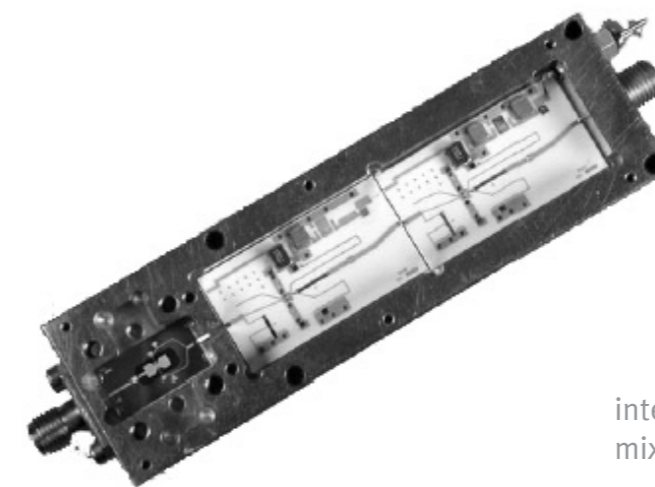

integrated Ka-band mixer/low-noise amplifier

## MICROSTRIP CONTROL COMPONENTS

e2v technologies' design and manufacturing expertise covers the whole range of control components operating at frequencies up to 94 GHz:

- Limiters
- Modulators
- Attenuators
- Phase shifters
- Switches
- Couplers
- Splitters/Combiners
- Detectors

These products are available as discrete connectorised modules, open carriers or integrated into more complex sub-systems. A selection of currently available modules is listed below:

Operating frequency (GHz)	Type	Description	Notes
0.1–0.5	<b>DA2015</b>	Digital attenuator	<0.2dB accuracy over 15dB range
X-band	<b>DA2064</b>	5-bit digital phase shifter	full MIL spec operating range
Ku-band	<b>DA2129</b>	PIN switch	>75 dB isolation
0.001–0.2	<b>DA2808</b>	Power splitter (3-way)	<0.1dB insertion loss variation
8–16	<b>DA2813</b>	Four-way power divider	Rugged construction
0.1–12	<b>DA3009</b>	Passive detector module	Back diode delivers very stable temperature performance
0.1–18	<b>DA3011</b>	Passive detector module	General purpose high sensitivity detector
0.1–18	<b>DA3013</b>	Passive detector module	As DA3011 but with a BNC output
16–17	<b>DA3040</b>	Variable output detector module	Adjustment screw allows accurate setup of voltage vs. power
26.5–40	<b>DA3070A</b>	Zero bias detector module	General purpose high sensitivity detector. WIG input

## SURFACE-MOUNT LIMITERS

Below are examples of surface-mount limiters available from e2v technologies.

Frequency range (GHz)	Type	Input power (dBm max.)	Fault power (dBm max.)	Output flat leakage (dBm max.)	Recovery (to 1 dB) (ns)	Insertion loss		VSWR	Description
						small signal (dB max.)	flatness (dB <sub>pk-pk</sub> max)		
9 – 10	<b>B3LT90811</b>	+38 (peak) <sup>[7]</sup>	+47 <sup>[7]</sup>	+17	100	1.4	—	1.4:1	Passive X-band limiter
2.7–3.3	<b>B3LT98161</b>	+26 (CW)	—	+14	200	1.0	0.3	1.5:1	3 GHz limiter
2.7–3.3	<b>B3LT98151</b>	+36 (CW) +40 (peak) <sup>[8]</sup>	—	+27	200	2.0	0.3	1.5:1	Integrated 3 GHz limiter and SPDT switch <sup>[9]</sup>



Passive X-Band Limiter

[7] Pulsed 1 μs, 25%

[8] 25% duty, 63 ms max.

[9] Isolation 40 dB min.

## AMPLIFIER MODULES

- Multi-octave bandwidths
- 2 to 18 GHz
- Max input VSWR 2:1
- Low noise and limiting
- GaAs FET variants available
- Saturated output power 16–30 dBm
- Supply voltage 15 V typical
- Custom designs available

Frequency (GHz)	Type	Bandwidth (%)	Gain (dB)	Noise figure (dB)	Output (dBm)	Input VSWR	Output VSWR
10	<b>DA65361</b>	2	20	—	30	1.5:1	1.5:1
10	<b>DA67011</b>	5	26	2.5	18	1.3:1	1.5:1
17	<b>DA65431</b>	3	35	2	10	1.3:1	2:1
9	<b>DA65371</b>	5	08	—	24	1.5:1	1.5:1
9	<b>DA67081</b>	2	28	1.1	10	1.5:1	1.5:1
9	<b>B3AM16011</b>	2	17	7	12	1.5:1	1.5:1
9	<b>B3AM16021</b>	2	11	1.8	13	1.5:1	1.5:1
9	<b>B3AM16031</b>	2	25	7	21	1.5:1	1.5:1



X-Band Limiting Amplifiers

X-Band Low Noise Amplifier

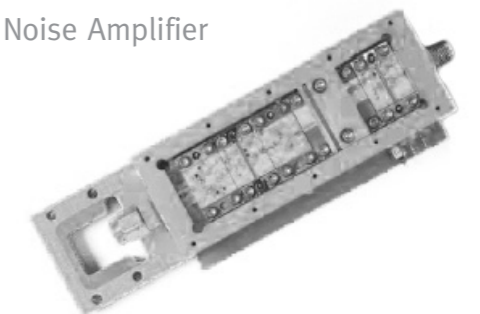

Ku-Band Low Noise Amplifier

## COIL PRE-AMPLIFIERS FOR MRI

- Completely non-magnetic
- Input/output protection
- Industry standard outline
- PIN diode input protection (on DA5977 and DA5979)
- Surface-mount or leaded package option
- Standard products cover 0.5 T to 3.0 T
- Custom design facility

Frequency (MHz)	Type	Max Noise Figure (dBm)	Gain (dB)	Input Z ( $\Omega$ )	Supply (V)	Dimensions (mm)	Notes
21.35 (0.5 T)	<b>DA5972-021</b>	0.70	27	$5 \pm j14$	+15	41 x 23 x 14	
42.30 (1.0 T)	<b>DA5972-042</b>	0.55	27	$7 \pm j14$	+15	41 x 23 x 14	
63.70 (1.5 T)	<b>DA5972-064</b>	0.55	27	$7 \pm j14$	+15	41 x 23 x 14	
25.60 (0.6 T)	<b>DA5973-026</b>	0.50	27	$6 \pm j5$	+8	42 x 23 x 12	
29.80 (0.7 T)	<b>DA5973-030</b>	0.50	27	$4 \pm j5$	+8	42 x 23 x 12	
63.72 (1.5 T)	<b>DA5973-064</b>	0.50	25	$6 \pm j5$	+8	42 x 23 x 12	
128.0 (3.0 T)	<b>DA5973-128</b>	0.60	23	$6 \pm j5$	+8	42 x 23 x 12	
29.80 (0.7 T)	<b>DA5975-030</b>	0.50	27	$4 \pm j5$	+8	42 x 23 x 12	
63.72 (1.5 T)	<b>DA5975-064</b>	0.50	25	$6 \pm j5$	+8	42 x 23 x 12	
128.0 (3.0 T)	<b>DA5975-128</b>	0.65	23	$6 \pm j5$	+8	42 x 23 x 12	
29.80 (0.7 T)	<b>DA5977-030</b>	0.50	27	$4 \pm j5$	+8	42 x 23 x 12	PIN diode input protection
63.72 (1.5 T)	<b>DA5977-064</b>	0.50	25	$6 \pm j5$	+8	42 x 23 x 12	PIN diode input protection
128.0 (3.0 T)	<b>DA5977-128</b>	0.65	23	$6 \pm j5$	+8	42 x 23 x 12	PIN diode input protection
63.72 (1.5 T)	<b>DA5979-064</b>	0.50	29.5	$2.0 \pm j2.5$	+9-15	41 x 24 x 12	PIN diode input protection
128.0 (3.0 T)	<b>DA5979-128</b>	0.55	29.5	$1.5 \pm j2.5$	+9-15	41 x 24 x 12	PIN diode input protection
42.58 (1.0 T)	<b>DA5980-0425</b>	0.5	26	$2.5 \pm j1.0$	+9.5	41 x 22 x 12	

## INTEGRATED MICROWAVE PACKAGES (IMPs)

e2v technologies develops and manufactures Integrated Microwave Packages (IMPs) for radars between L-band and Ka-band. IMPs combine a range of microwave elements in a single package customised to the user's requirements and providing optimum microwave performance.

The microwave elements can include duplexer circulators, isolators, filters, power monitoring facilities, noise generators, receiver protectors and electronic drive circuits with built-in test (BIT). The following specifications are typical:

### RF HEADS

Frequency	Type	Band-width (%)	Peak power Active (kW)	Peak power Passive (kW)	Mean power Active (W)	Mean power Passive (W)	RF leakage (mW)	VSWR	Insertion loss (dB)	Recovery to -1 dB (ns)
Ku-Band	<b>B3IM18301</b>	5.0	—	0.8	—	6.0	20	1.4	1.2	350
Ka-Band	<b>B3IM22171</b>	1.0	0.2	—	40	—	10	1.3	1.5	250

### RF RECEIVERS

Frequency (GHz)	Type	Details	MDS (dBm typical)	Noise figure (dB max)	Power supplies (V)
9.3 — 9.5	<b>B3IM16161</b>	4 bandwidths, performance monitoring, AFC, 25kW	-100	4.7	+15, +5, -15
9.1 — 9.3	<b>B3IM16171</b>	Frequency variant of B3IM16161	-100	4.7	+15, +5, -15
9.3 — 9.5	<b>B3IM16181</b>	High definition (50 MHz bandwidth) plus performance monitoring	-100	4.7	+15, +5, -5.2
9.1 — 9.3	<b>B3IM16191</b>	Frequency variant of B3IM16181	-100	4.7	+15, +5, -5.2
9.35 — 9.55	<b>B3IM16411</b>	3 bandwidths, log/linear video amplifiers, AFC, 3-port circulator, 25 kW power handling	-100	4.7	+15, +5, -5.2
9.1 — 9.3	<b>B3IM16421</b>	Frequency variant of B3IM16411	-100	4.7	+15, +5, -5.2
9.3 — 9.5	<b>B3IM16431</b>	Version of B3IM16411 with performance monitoring, 4-port circulator, 25 kW	-100	4.7	+15, +5, -5.2
9.1 — 9.3	<b>B3IM16441</b>	Frequency variant of B3IM16431	-100	4.7	+15, +5, -5.2
9.1 — 9.3	<b>B3IM16451</b>	Version of B3IM16411 with 4-port circulator, 25 kW	-100	4.7	+15, +5, -5.2
9.35 — 9.55	<b>B3IM16511</b>	Version of B3IM16411 with AFC optimised at 10 kW	-100	4.7	+15, +5, -5.2
9.1 — 9.3	<b>B3IM16521</b>	Version of B3IM16421 with AFC optimised at 10 kW	-100	4.7	+15, +5, -5.2
9.3 — 9.5	<b>B3IM16531</b>	Version of B3IM1643 with AFC optimised at 10 kW	-100	4.7	+15, +5, -5.2
9.35 — 9.55	<b>B3IM16611</b>	Version of B3IM16411 with AFC optimised at 4 kW	-100	4.7	+15, +5, -5.2
9.1 — 9.3	<b>B3IM16621</b>	Version of B3IM16421 with AFC optimised at 4 kW	-100	4.7	+15, +5, -5.2
Ka-Band	<b>B3IM22061</b>	Integrated front-end, comprising TR cell, active limiter and low-noise amplifier/balanced mixer	—	10	+5, -15
Ka-Band	<b>B3IM22071</b>	Integrated front-end, comprising active limiter, local oscillator and low-noise amplifier/image rejection mixer	—	7	+5, -15
Ka-Band	<b>B3IM22081</b>	Integrated front-end, comprising circulator, active limiter, local oscillator, low-noise amplifier/image rejection mixer and magnetron	—	8	+5, -15, +EHT



Ka-Band IMP

## CUSTOM DESIGNED INTEGRATED MICROWAVE PACKAGES

e2v technologies utilises a broad spectrum of technologies to produce a highly integrated RF module for key defence applications. The following illustrate application-specific products.

### X-Band TWTA Driver Amplifier Module

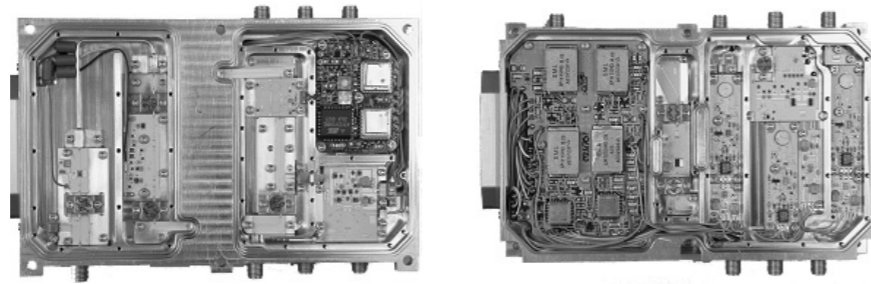

X-band power amplifier with integrated variable attenuator with 30 dB of attenuation in 0.5 dB steps. Output power 28 dBm with integrated precision video detectors allowing monitoring of input and output power levels. High input-output isolation (>60dB) and low mass (<700g). Military airborne environment compatibility

X-band Driver AmplifierModule, showing internal views of microwave circuit and control electronics

### Ultra Low Noise UHF Sources

Surface Acoustic Wave Oscillators provide UHF output with very good close-to-carrier phase noise, together with defined temperature stability and long-term stability. Typically frequencies are in the range 600MHz to 1200MHz. Such oscillators are combined with power supplies, output amplification and switching to realise a compact, high performance, multiple-frequency source module.

To further enhance the electrical performance whilst under mechanical vibration, proprietary mechanical structures are used to isolate the SAW oscillators from the module housing. Oscillator module construction is compatible with military airborne environmental requirements.

- Surface Acoustic Wave (SAW) oscillator technology
- Ultra low RF Noise performance
- Ultra low Phase Noise performance
- Electronic switching between multiple, independent SAW Oscillator frequency channels (TTL interface)
- UHF frequency band



Ultra low noise UHF Oscillator Module

### X-Band power splitter

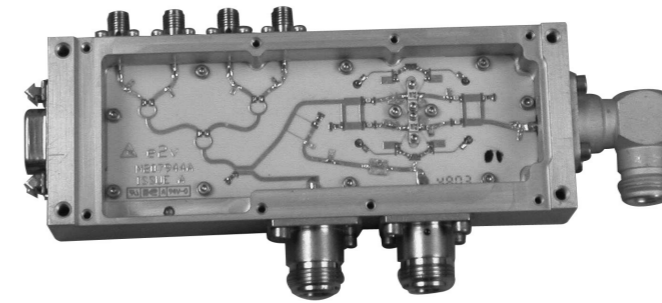

9 GHz RF amplifier and power splitter sourcing two pairs of balanced, isolated RF LO drive signals and two coupled power levels for coherent parallel receiving channels

### Upconverter/Multiplier

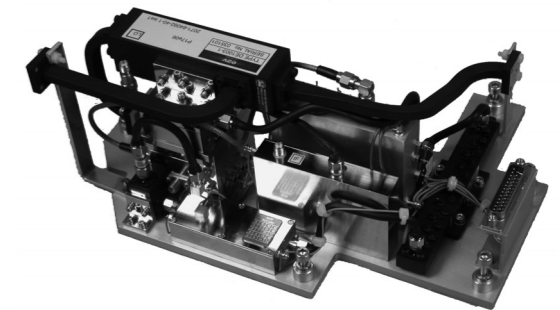

Upconversion module multiplying input S-Band signals to 35GHz. No significant fundamental, harmonics or spurious on output signal.

### KU-Band integrated RF Head

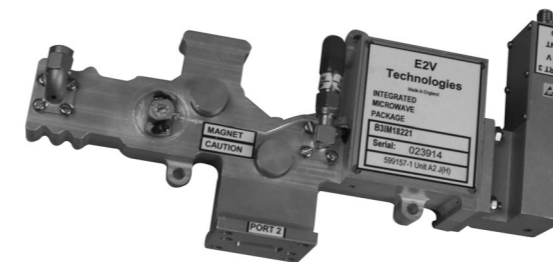

15 GHz circulator, limiter and low noise amplifier

e2v technologies is capable of utilising a broad spectrum of technologies to produce a highly integrated RF module for key defence applications. The following illustrate three application-specific products.

X-Band TR Module for phased array radar

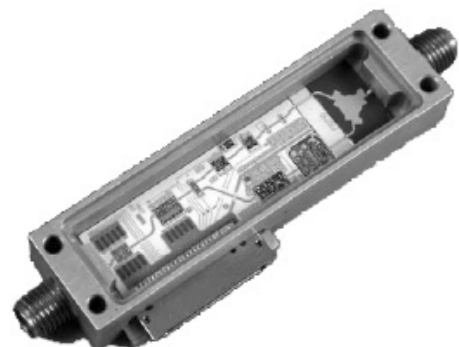

Transmit-receive module emitting 30 dBm output power inclusive of integral attenuators and phase shifters. Gold-on-ferrite isolator and extensive use of MMIC technology throughout.

X-band power amplifier, variable attenuator with 30 dB of attenuation in 0.5 dB steps. Output power 28 dBm, built-in detectors allowing monitoring of input and output powers.

X-Band TWTA Driver Amplifier Module

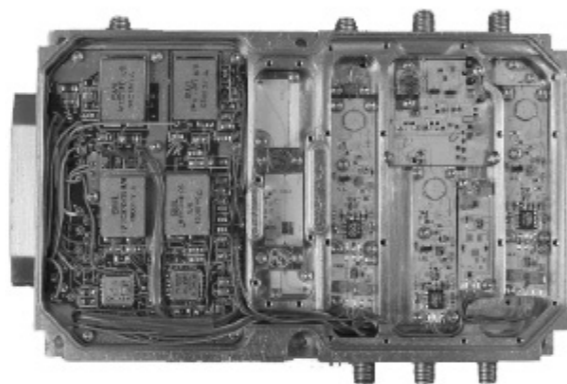

94 GHz Radar Head

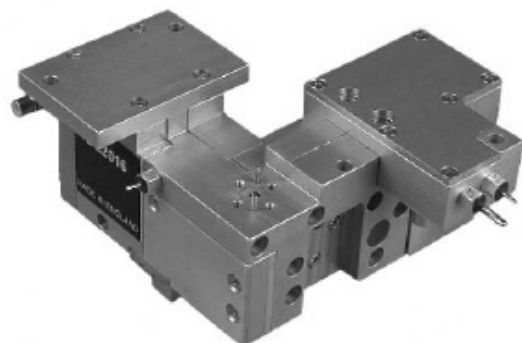

94 GHz radar head with one transmit-receive port and one receive only port, incorporating a Gunn diode microwave source, isolators, mixers, down converters and IF amplification.

### CIRCUITS

e2v technologies' circuits facilities provide not only internal expertise and supply of circuits for the integrated modules offered, but also provide a custom circuit foundry and assembly service for military and commercial customers.

Service offered includes:

- Full technical advice on the most suitable circuit medium for any given application
- Mask-making facility from customer's DXF file, reducing lead times.
- Full circuit design service available, given an agreed specification
- Laser system to trim, scribe, through hole form and profile circuits
- Full assembly of chip and wire or surface-mount components
- Full analytical and environmental facilities available
- Prototype quantities to volume manufacture

Circuit media offered:

- Standard thick film to 8 conductor layers if required
- Photo-etchable thick film — capable to 100 GHz
- Thin film — capable to 100 GHz
- Softboard

Materials include:

- Alumina (96%, 99.5%, 99.6%)
- Ferrite
- Z-cut quartz (single crystal)
- Fused quartz
- Zirconium Tin Titanate
- Aluminium Nitride

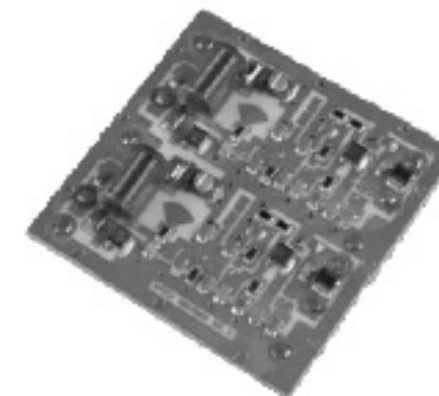

Example of hybrid chip and wire circuit assembly



Laser defined thin film substrate

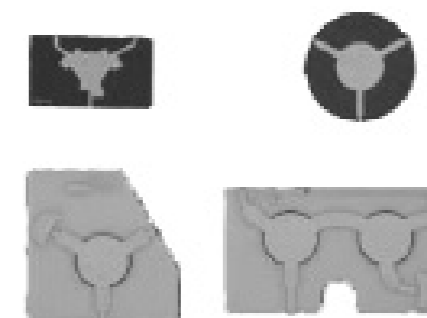

Examples of patterned ferrite devices

## MICROWAVE SEMICONDUCTORS

A selection of e2v technologies' microwave (and mmwave) semiconductors can be seen on pages 23 through 28. This selection represents e2v technologies' long history of design and manufacture of semiconductors that were built into demanding custom applications by both military and commercial OEMs for major programs.

e2v technologies continues to support long term programme requirements for microwave semiconductors, providing a UK source to many worldwide electronic system designers.

The custom service available provides microwave semiconductors fabricated entirely using in-house facilities, to an agreed customer specification. This encompasses the following:

- Specification and purchase of semiconductor epitaxial material
- Processing of semiconductor material
- Packaging of the processed die into the required package type
- Electrical test to meet agreed specified performance on in-house prepared test fixtures
- Full environmental testing to the agreed specification
- Supported by full in-house analytical abilities

Semiconductor device types offered are:

- GaAs Graded Gap Gunn Diodes (28 – 100 GHz)
- GaAs Schottky Diodes (28 – 100 GHz)
- GaAs Varactor Diodes
- Silicon PIN Diodes

In addition, the capability exists to produce custom GaAs PINs, Si Mixers and Si Varactors for specialist applications.

## GALLIUM ARSENIDE SCHOTTKY DIODES FOR MIXERS

Frequency	Type	Typical forward voltage at 100 $\mu$ A (mV)	Minimum reverse voltage at 10 $\mu$ A (V)	Typical series resistance@ 10-20 mA( $\Omega$ )	Typical junction capacitance at 0 V (fF)	Outline (see page 24)	Application
X-Band	<b>DC1301</b>	600	2	5	80	20	Microstrip
X-Band	<b>DC1301C</b>	600	2	5	80	20	Microstrip
X-Band	<b>DC1332</b>	600	2	5	80	59	Microstrip
Ku-Band	<b>DC1306</b>	700	2	4	100	107	Microstrip
Ku-Band	<b>DC1323</b>	600	2	6	60	20	Microstrip
Ku-BAnd	<b>DC1334</b>	600	2	6	60	59	Microstrip
Ku-Band	<b>DC1340</b>	700	2	4	100	107	Microstrip
Ka-Band	<b>DC1338</b>	700	2	4	75	107	Microstrip
Ka-Band	<b>DC1339</b>	700	2	4	55	107	Microstrip
Ka-Band	<b>DC1343</b>	700	2	4	80	111	Microstrip
30-100 GHz	<b>DC1346</b>	720	2	7 max	40 max	107	Microstrip

## GALLIUM ARSENIDE SCHOTTKY DIODES FOR DETECTORS

Frequency	Type	Typical forward voltage at 100 $\mu$ A (mV)	Minimum reverse voltage at 10 $\mu$ A (V)	Typical series resistance@ 10-20 mA( $\Omega$ )	Typical junction capacitance at 0 V (fF)	Outline (see page 29)	Application
X-Band	<b>DC1312</b>	600	2	5	80	59	Microstrip
X-Band	<b>DC1321</b>	600	2	5	80	20	Microstrip
X-Band	<b>DC1314</b>	600	2	5	60	59	Microstrip
Ku-Band	<b>DC1316</b>	600	2	6	60	20	Microstrip

NB: All characteristics shown are typical at T-ambient of 25°C

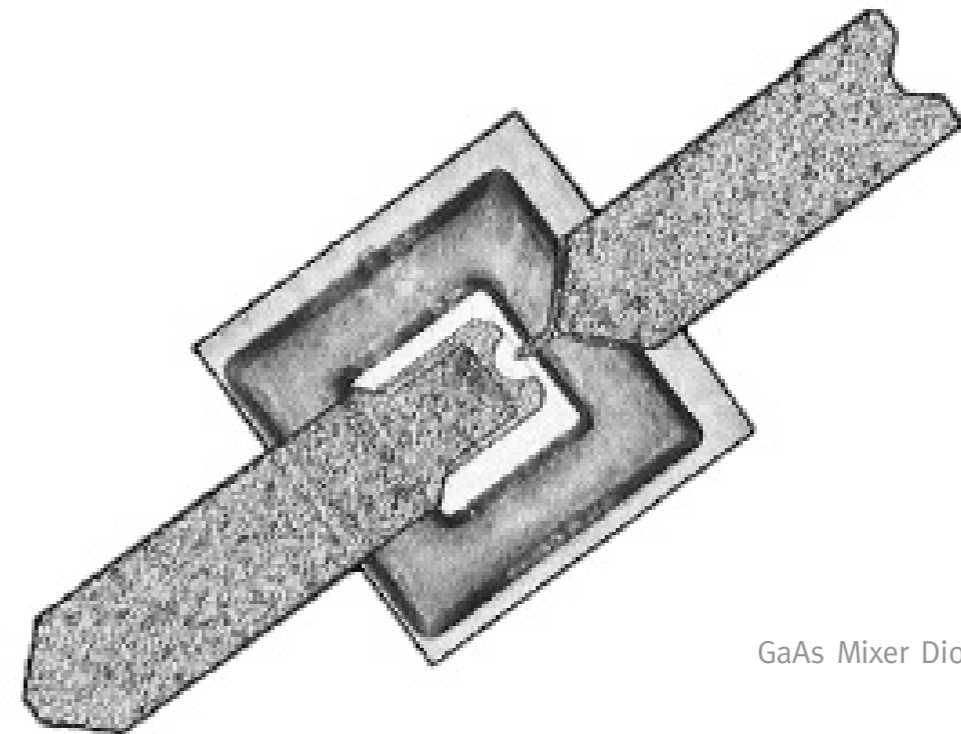

GaAs Mixer Diode

## SILICON SCHOTTKY DIODES FOR MIXERS

Frequency	Type	Typical forward voltage at 100 $\mu$ A (mV)	Minimum reverse voltage at 10 $\mu$ A (V)	Typical series resistance ( $\Omega$ )	Typical junction capacitance at 0 V (fF)	Outline (see page 29 & 30)	Application
S-Band	<b>DC1508</b>	350	2	10	180	20	Microstrip
S-Band	<b>DC1511</b>	350	2	10	180	59	Microstrip
S-Band	<b>DC1571</b>	200	2	10	180	20	Microstrip (low drive)
S-Band	<b>DC1573</b>	200	2	10	180	59	Microstrip (low drive)
X-Band	<b>DC1536</b>	400 at 2.5 mA	2	18	150	107	Microstrip
X-Band	<b>DC1575</b>	200	2	20	80	20	Microstrip (low drive)
X-Band	<b>DC1578</b>	200	2	20	80	59	Microstrip (low drive)
X-Band	<b>DC1596</b>	200	—	20	150	59	Microstrip (Protected Mixer)
Ku-Band	<b>DC1524</b>	350	2	20	60	20	Microstrip

## SILICON SCHOTTKY DIODES FOR DETECTORS

Frequency	Type	Typical forward voltage at 100 $\mu$ A (mV)	Minimum reverse voltage at 10 $\mu$ A (V)	Typical series resistance 10-20 mA ( $\Omega$ )	Typical junction capacitance at 0 V (fF)	Outline (see page 29)	Application
S-Band	<b>DC1513</b>	350	2	20	80	59	Microstrip
S-Band	<b>DC1517</b>	350	2	20	80	20	Microstrip
X-Band	<b>DC1512</b>	350	2	20	80	59	Microstrip
X-Band	<b>DC1516</b>	350	2	20	80	20	Microstrip
Ku-Band	<b>DC1520</b>	350	2	20	60	20	Microstrip

## SILICON ZERO BIAS SCHOTTKY DIODES FOR DETECTORS

Frequency	Type	Typical forward voltage at 100 $\mu$ A (mV)	Typical series resistance ( $\Omega$ )	Video impedance @9.375GHz ( $\Omega$ )	Tangential sensitivity @9.375GHz (fF)	Outline (see page 29)	Application
	<b>DC1557</b>	50	40	3000	-50	59	
X-Band	<b>DC1553</b>	50	40	3000	-50	20	Microstrip (zero bias)

## WAVEGUIDE PIN DIODES

Suitable for use as switches, modulators, attenuators and limiters.

- Low resistance
- Frequency range 10 MHz to 18 GHz
- Low capacitance
- Mesa and planar versions available
- High breakdown voltage

Type	Minimum reverse voltage (V)	Maximum forward resistance ( $\Omega$ )	Maximum total capacitance (pF)	Typical lifetime $\tau_L$ (ns)	Thermal resistance ( $^{\circ}$ C/W)	Outline (see page 29)
<b>DC2110A</b>	50	2.0 at 20 mA	0.4	5	50	00
<b>DC2118A</b>	100	1.0 at 100 mA	0.4	50	30	00
<b>DC2119A</b>	100	1.0 at 100 mA	0.4	50	30	00

## MICROSTRIP PIN DIODES FOR SWITCHES

- Low resistance
- High breakdown voltage
- Low capacitance
- Mesa and planar versions available

Frequency range (GHz)	Type	Maximum peak input power (W)	Maximum mean input power (W)	Minimum reverse voltage (V)	Insertion loss at 20 V, 12 GHz (dB)	Isolation at 20 mA, 9.5 GHz (dB)	Typical switching speed (ns)	Outline (see page 29)
1–12	<b>DC2610A</b>	100	10	50	0.6	20	6	30
1–12	<b>DC2611</b>	100	10	50	0.6	20	6	31
1–12	<b>DC2612A</b>	10	1	20	0.6	20	3	30
1–12	<b>DC2613</b>	10	1	20	0.6	20	3	31
1–12	<b>DC2614*</b>	100	25	100	0.5	20	40	31
1–12	<b>DC2615*</b>	100	25	100	0.5	20	40	31
1–12	<b>DC2616</b>	10	1	20	0.6	20	3	31
1–12	<b>DC2618A</b>	100	25	100	0.5	20	40	30
1–12	<b>DC2619A*</b>	100	25	100	0.5	20	40	30
1–12	<b>DC2652A*</b>	10	1	20	0.6	20	3	30

NB: All characteristics shown are typical at T-ambient of 25 $^{\circ}$ C

\* Anode is base. All others cathode is base

## MILLIMETRE WAVE GRADED GAP GUNN DIODES

The DC1200-T series extends the range of high power, graded gap, GaAs CW Gunn diodes further into the millimetre wave frequency band. They offer superior stability where low  $df/dt$ , low  $df/dv$  and cold start turn-on are at a premium.

- Low FM and AM noise
- Fixed frequency or wideband
- High efficiency
- High reliability
- Custom devices available
- Military temperature range

Within Frequency band (GHz)	Type	Minimum output power (mW)	Typical operating voltage (V)	Typical operating current (mA)
26-40	DC1276F-T	50	5.0	400
26-40	DC1276G-T	100	5.0	600
26-40	DC1276H-T	200	5.0	850
26-40	DC1276J-T	300	5.0	1200
40-60	DC1277D-T	20	3.5	350
40-60	DC1277E-T	30	3.5	400
40-60	DC1277F-T	50	3.5	500
40-60	DC1277G-T	100	3.5	700
60-75	DC1278D-T	20	6.0	600
60-75	DC1278E-T	30	6.0	650
60-75	DC1278F-T	50	6.5	700
75-110	DC1279B-T	10	5.0	500
75-110	DC1279C-T	15	5.0	550
75-110	DC1279D-T	20	5.0	600
75-110	DC1279E-T	30	5.0	650
75-110	DC1279F-T	50	5.0	700

All in 106 outline (see p. 30)

All characteristics shown are typical at T-ambient of 25°C

Centre frequency of operation to be specified



Outline 106, 10 X actual size

## GALLIUM ARSENIDE TUNING VARACTORS

This range of epitaxial GaAs Schottky barrier variable capacitance diodes is designed primarily for electronic tuning of Gunn and transistor microwave oscillators. They have the advantage over silicon tuning diodes in that the required change in capacitance occurs over a lower tuning voltage range and, as such, is more compatible with Gunn and transistor power supplies.

GaAs varactors also exhibit excellent low noise characteristics.

The total capacitance includes the encapsulation capacitance which is approximately 0.25 pF for outline 00, and 0.08 pF for outline 20. Diodes can be supplied to reduced total capacitance spread to special order.

Type	Minimum working voltage (V)	Total capacitance (pF)	Typical capacitance ratio		Typical quality factor at 10 GHz (QV)	Outline (see page 29)
			0 – 20 V	0 – 30 V		
DC4301A	20	2.2	4.5	—	4.3	00
DC4302A	20	1.3	4.5	—	6.0	00
DC4303A	20	0.8	4.5	—	6.6	00
DC4304A	20	3.3	4.5	—	3.4	00
DC4305A	20	4.7	4.5	—	3.3	00
DC4301B	30	2.2	4.5	6.0	4.3	00
DC4302B	30	1.3	4.5	6.0	6.0	00
DC4303B	30	0.8	4.5	6.0	6.6	00
DC4304B	30	3.3	4.5	6.0	3.4	00
DC4305B	30	4.7	4.5	6.0	3.3	00
DC4371A	20	2.2	4.5	—	4.3	20
DC4372A	20	1.3	4.5	—	6.0	20
DC4373A	20	0.8	4.5	—	6.6	20
DC4374A	20	3.3	4.5	—	3.4	20
DC4375A	20	4.7	4.5	—	3.3	20
DC4371B	30	2.2	4.5	6.0	4.3	20
DC4372B	30	1.3	4.5	6.0	6.0	20
DC4373B	30	0.8	4.5	6.0	6.6	20
DC4374B	30	3.3	4.5	6.0	3.4	20
DC4375B	30	4.7	4.5	6.0	3.3	20

NB: All characteristics shown are typical at T-ambient of 25°C



Outline 00, 10 X actual size

### SEMICONDUCTOR PACKAGE OUTLINES (DIMENSIONS IN MILLIMETRES)

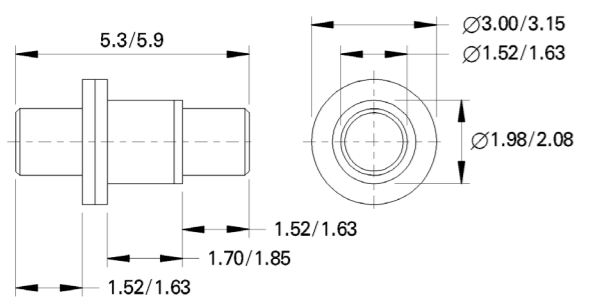

Package 00

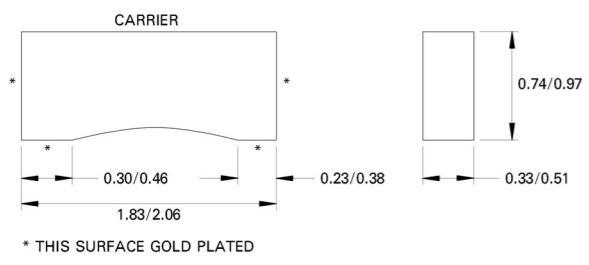

Package 20

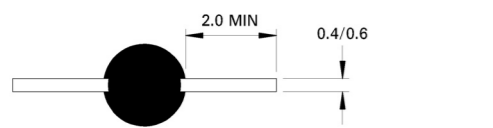

Package 30

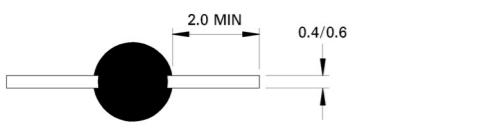
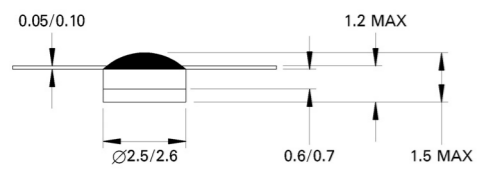

Package 31

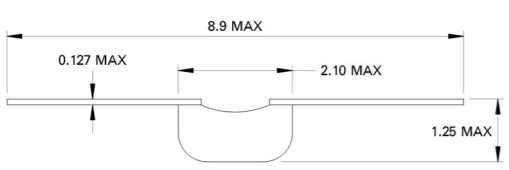
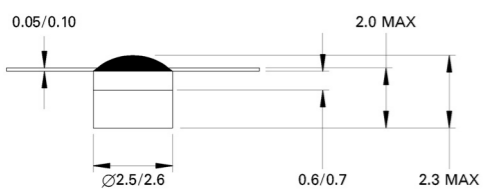

Package 59

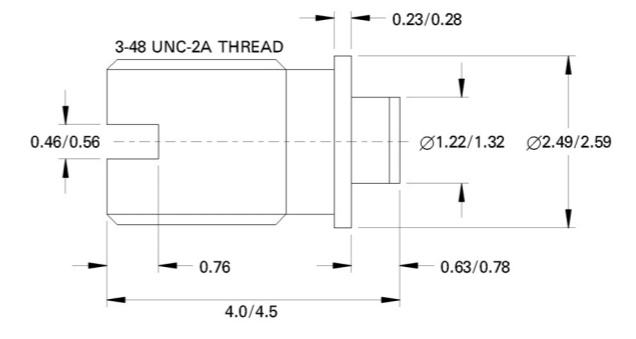
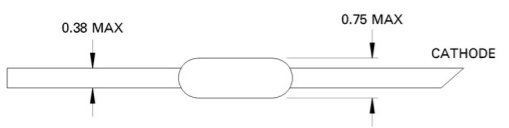

Package 86

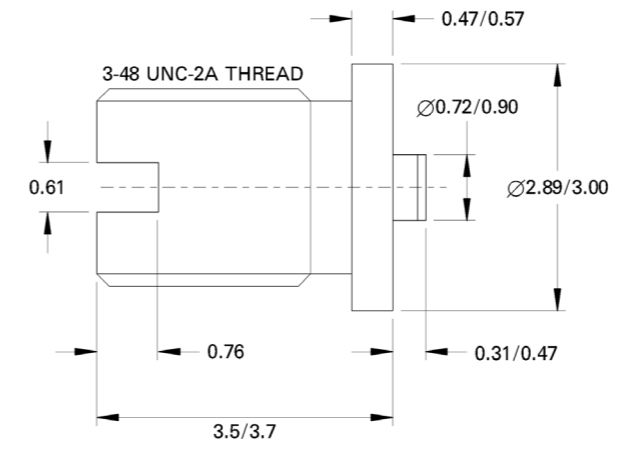

Package 106

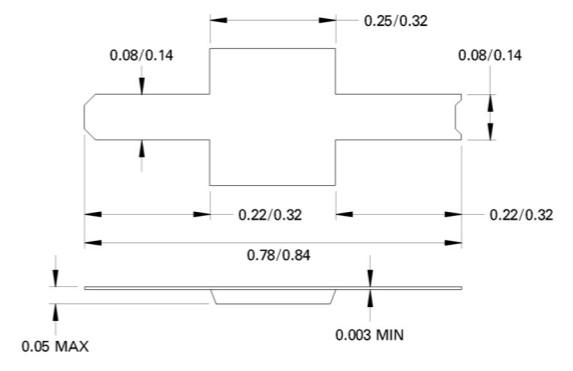

Package 107

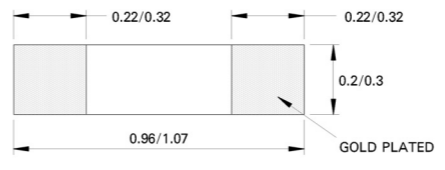

Package 111



## ELECTRONIC SAFETY AND ARMING

e2v technologies has been active in the Electronic Safety and Arming (ES&A) technology arena since 1984. The activity began with e2v technologies funding Exploding Foil Initiator (EFI) technology in conjunction with RARDE (now QinetiQ and Dstl).

Through the late 1980s and early 1990s, work was concentrated on EFI research and characterisation, explosive material characterisation and firing circuit development.

e2v technologies secured its first product contract for an electronic safety and arming unit (ESAU), including EFI detonator, in 1994. This contract resulted in qualification of a basic firing system in 1996 and delivery of approximately 1,000 production devices.

Since the mid-1990's, the activity has grown and is now a key part of e2v technologies' future business strategy. Today, e2v technologies supplies electronic safety and arming units and firing systems containing EFI detonators to more than ten weapon systems. These include torpedoes, sea mines, ground to air missiles and explosive ordnance disposal systems.

Ongoing technology research into low energy EFIs and next generation electronic safety and arming systems is securing the e2v technologies portfolio for the future.

Key system parameters for the devices are as follows:

### Exploding Foil Initiators

- HNS explosive fill
- Flexi-circuit or rigid board construction
- Threshold energy 0.2 J
- Explosive take-over proven into various warhead and explosive chain materials
- 99.9% @ 95% confidence all fire energy: 0.29 J
- Characterised against STANAG 4560
- Material compatibility tested against STANAG 4147

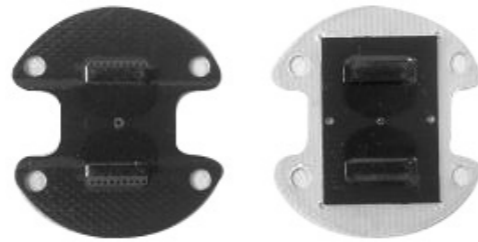

Examples of e2v Exploding Foil Initiators, rigid board configurations

### Firing Systems

- Low inductance firing capacitor
- 3-electrode triggered vacuum switch
- Flexi-circuit or rigid board interconnect
- 0.45 J typical storage energy
- DC-DC converter to provide high voltage for firing capacitor
- <100 ms capacitor charge time
- 9 V to 40 V dc input
- <2 μs trigger input to explosive output delay time



SAU Electronics Assembly for ground to air missile application

### Electronic Safety and Arming Units

- Solid-state sensors and electronics detect independent environmental events, e.g.
  - Acceleration (launch and / or flight)
  - Gas pressure (rocket motor)
  - Water pressure (underwater weapons)
  - Umbilical break (from various platforms)
- Safety switching and logic realised in discrete circuitry to maximise safety
- Electrical, mechanical and explosive interfaces designed to meet specific weapon application
- Designed to meet UK PP101 and PP102



Electronic Safety, Arming and Initiation Device (ESAID) for ground to air missile application

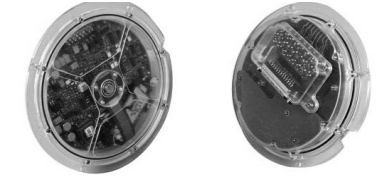

Internal views of ESAID electronics assembly, showing captive EFI and detonator explosive pellet (left) and electrical interface connection (right)

## ES&A PRODUCT OVERVIEW

Type	Application	Environments Sensed	Operating Voltage	Arm Time	Explosive Interface
EIS1061	Underwater grenade	Electrical Inputs	12V	80ms	Removable Detonator
EIS1161	Underwater EOD	Electrical Inputs	24V	100ms	Removable Detonator
EIS1171	Sea Mine	Electrical Inputs	30V	40 secs.	Removable Detonator
EIS1211	Surface / Air Missile	Acceleration / Electrical Input	28V	100ms	Removable Detonator
EIS1221	Surface / Air Missile	Acceleration / Umbilical Break and Impact Sensor for initiation	28V	75ms	Integral Detonator
EIS1241	Underwater EOD	Electrical Inputs	12V	5mins.	Integral Detonator
EIS1251	EOD	Electrical Input	12V	500ms	Removable Detonator arm & fire
EIS1291	Torpedo	Lanyard Pull / Water Pressure	33V	400ms	Removable Detonator

## FREE ELECTRON TECHNOLOGIES

The Chelmsford-based Free Electron Technologies (FET) operation of e2v technologies is founded on more than 56 years of experience in the development and manufacture of electronic vacuum devices. During that time, the range of products offered, and the technologies drawn on have grown to produce modern components addressing the requirements of the most demanding of applications.

Through a consciously developed partnering approach, the FET product range has evolved to address customer requirements by ensuring that their needs are clearly understood. To this end, e2v's engineers and scientists frequently work closely with individual customers at key stages of new product development, ensuring clear understanding of requirements and exemplary customer service.

This philosophy has served both e2v technologies and its customers well, with products now being key to many global market sectors including cancer treatment, defence systems, industrial processes, digital television transmission, satellite communications, high power switching and radar. Many people in the world today are impacted to some extent by an e2v product almost every day of their lives. Whether this be making a phone call, watching TV, undergoing radiotherapy or travelling by air - e2v technologies' vacuum components will be a part of the systems that make it all happen smoothly, repeatably and reliably.

FET also has a long tradition of utilising a wide variety of innovative processes, manufacturing techniques and production materials:

**Design** using CAD and numerical modelling is used extensively during the design phase of any new product. 2D and 3D packages, as well as custom modelling packages, are used by a dedicated modelling team in order to provide manufacturing areas with comprehensive performance data.

**Chemical and thermal processing** of raw materials and individual components is pivotal to the quality of finished products. Many materials exhibit properties in vacuum very different to those normally expected in air. As a result, plating with precious metals, ion implantation, thin film coating and mechanical surface texturing are some of the techniques used to enhance the performance of a component on an atomic or electronic level.

**Ceramic-to-metal vacuum seals** are produced using propriety metallising paints and ceramic substrates selected for individual applications. In some instances, the ceramic purity is almost high enough to become sapphire.

**Cathodes**, designed to provide stable electron emission for tens of thousands of hours of continuous operation are also manufactured in-house. Cathodes with doped surfaces that



S-Band Linac Magnetron

reduce their operational temperature, or increase the current they can provide, cater for high current applications. It is not uncommon for e2v technologies' tubes to achieve lives in excess of 100,000 hours.

**Manufacture of products** employs state-of-the-art welding and vacuum brazing techniques to ensure the highest possible reliability and tube integrity. Clean manufacturing areas ensure contamination of the products and their individual components is minimised at every stage.

**Proprietary vacuum processing** of FET's products utilises the latest spectrographic technology to guarantee the integrity of device vacuum and long life of product in the field.

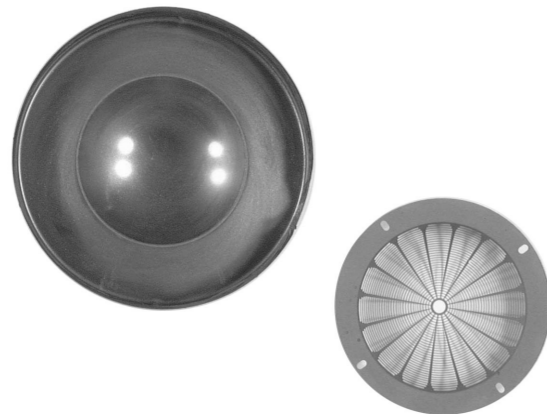

Pyrolytic Graphite Grid

## MAGNETRONS

### LINEAR ACCELERATOR MAGNETRONS

e2v technologies Linac Magnetrons are specifically designed for use in electron beam linear accelerators for medical or industrial applications.

All these magnetrons have mechanical or electronically driven tuners to enable automatic frequency control (AFC) to be employed.



S-Band Linac Magnetron

Frequency range (MHz)	Type	Peak output power (MW)	Typical operation				Duty cycle	Tuning	Accessories available (see below)	Class (see below)
			Peak anode voltage (kV)	Peak anode current (A)	Pulse duration (µs)					
2993 — 3002	<b>MG5125</b>	2.0	43	100	5.0	0.001	Mechanical	MT	SWX	
2993 — 3002	<b>MG5125P</b>	2.0	43	100	5.0	0.001	Mechanical	MT	SWX	
2993 — 3002	<b>MG5125X</b>	2.0	43	100	5.0	0.00126	Mechanical	MT	SWX	
2993 — 3002	<b>MG5193</b>	2.6	47	110	5.0	0.0012	Mechanical	MT	EWX	
		0.5	25	50						
2993 — 3002	<b>MG6060</b>	2.6	47	110	5.0	0.0012	Mechanical	MT	EWX	
2993 — 3002	<b>MG5349</b>	3.1	50	115	5.0	0.0013	Mechanical	MT	EWX	
		1.8	30	140	3.0	0.0012				
2852 — 2861	<b>M5028</b>	5.5	48	210	3.0	0.0006	Mechanical	MRH	EWZ	
		1.8	30	140	3.0	0.0012				
2852 — 2861	<b>MG6028</b>	5.5	48	210	3.0	0.0006	Electronic	MRH	EWZ	

### ACCESSORIES AND MAGNETS FOR LINEAR ACCELERATOR MAGNETRONS

Description	Type	Used on
Water cooled electromagnet	<b>MG6062</b>	MG5125, MG5125P, MG5125X, MG5193, MG6060
Water cooled electromagnet	<b>MG6053</b>	MG5349, MG6090
Water cooled electromagnet and transition to UG-53/U	<b>MG6030</b>	M5028, MG6028
Transition section to WG10/WR284		
rectangular flange CPR284F	<b>M4152S</b>	MG5125, MG5125P, MG5125X, MG5193, MG6060
Radiation absorber	<b>MA761</b>	M5028
Radiation absorber	<b>MG6016</b>	MG6028
Capacitor	<b>MA997A</b>	M5028, MG6028

#### ACCESSORIES

M Separate magnet  
 T Transition to waveguide  
 R Radiation absorber  
 H Heater/cathode capacitor

#### CLASS

**Magnetic Field**  
 E Electromagnet  
 S Separate magnet  
 P Permanent magnet

**Cooling**  
 A Forced-air  
 W Water  
 B Conduction  
 N Natural

**Output**  
 X Requires transition section  
 Z Requires electromagnet with launching section  
 G Waveguide  
 C Coaxial

## CW MAGNETRONS (FIXED FREQUENCY)

This range of magnetrons is typically used for microwave heating and processing applications.

Frequency range (MHz)	Type	Typical output power (kW)	Typical operation			Class (see footnotes page 28)
			Anode voltage (kV)	Anode current (A)	Load VSWR max	
896 ± 5	<b>BM30LA</b>	30	12.5	3.0	2.0:1	EWAZ
915 ± 5	<b>BM30LB</b>	30	12.5	3.0	2.0:1	EWAZ
896 ± 5	<b>BM50LA</b>	50	15	4.1	2.0:1	EWAZ
915 ± 5	<b>BM50LB</b>	50	15	4.1	2.0:1	EWAZ
896 ± 5	<b>BM60LA</b>	60	16	4.5	2.0:1	EWAZ
915 ± 5	<b>BM60LB</b>	60	16	4.5	2.0:1	EWAZ
896 ± 5	<b>BM75LA</b>	75	17	5.1	1.5:1	EWAZ
915 ± 5	<b>BM75LB</b>	75	17	5.1	1.5:1	EWAZ
896 ± 5	<b>BM100LA</b>	100	18	6.0	1.5:1	EWAZ
915 ± 5	<b>BM100LB</b>	100	18	6.0	1.5:1	EWAZ

## CW MAGNETRON ACCESSORIES

Type	Description	Used on
<b>F1152-62</b>	Circulator	BM Series (896 MHz)
<b>F1152-63</b>	Circulator	BM Series (915 MHz)
<b>MA2729A</b>	Cathode connectors	BM Series
<b>MA3543A</b>	RF washer	BM Series
<b>MA3544A</b>	Cathode adaptors	BM Series
<b>MA3568A</b>	Pole piece	BM Series

## PULSE MAGNETRONS — S-BAND

This range of magnetrons is typically used in radar applications. Fixed frequency types except where otherwise indicated

Frequency range (MHz)	Type	Typical operation					Class (see footnotes page 28)
		Peak output power (kW)	Peak anode voltage (kV)	Peak anode current (A)	Pulse duration (µs)	Duty cycle	
3040 — 3060	<b>MG5314</b>	4.9	4.3	2.5	0.8	0.00064	PBNG
3040 — 3060	<b>MG5315</b>	12	5.8	5.0	0.8	0.00064	PBNG
3025 — 3075	<b>MG5289</b>	26 <sup>[11]</sup>	7.0	8.0	1.0	0.001	PANX
	<b>MG5223</b>						
3040 — 3060	<b>MG5223F</b>	30	8.0	8.0	0.55	0.00055	PANG
3025 — 3075	<b>MG5267</b>	56	9.0	15	0.55	0.00055	PANX
3025 — 3075	<b>MG5240</b>	60	9.3	15	0.55	0.00055	PAG

[10] Check with e2v technologies for availability

[11] Maintenance type

## PULSE MAGNETRONS - X-BAND

Fixed frequency types except where otherwise indicated

Frequency range (MHz)	Type	Peak output power (kW)	Typical operation				Class (see footnotes page 28)
			Peak anode voltage (kV)	Peak anode current (A)	Pulse duration (µs)	Duty cycle	
9380 — 9440	<b>MG5353</b>	1.5	2.0	2.0	0.5	0.001	PNG
9380 — 9440	<b>MG4004</b>	4.0 <sup>[10]</sup>	3.7	3.0	1.0	0.001	PANG
	<b>MG5238A</b>						
9415 — 9475	<b>MG5238B</b>	4.0 <sup>[11]</sup>	3.7	3.0	1.0	0.001	PNG
9415 — 9475	<b>MG5243</b>	4.0	3.7	3.0	1.0	0.001	PNG
9380 — 9440	<b>MG5248</b>	4.0	3.7	3.0	1.0	0.001	PNG
9380 — 9440	<b>MG5251</b>	4.0 <sup>[11]</sup>	3.7	3.0	1.0	0.001	PNG
9210 — 9270	<b>MG5274</b>	4.0 <sup>[14]</sup>	3.7	3.0	1.0	0.001	PNG
9380 — 9440	<b>MG5388</b>	4.0	3.7	3.0	1.0	0.001	PNG
9380 — 9440	<b>MG5388C</b>	4.0	3.7	3.0	1.0	0.001	PNG
9345 — 9405	<b>MG5401</b> <sup>[12]</sup>	4.0	3.7	3.0	4.0	0.00054	PNG
9380 — 9440	<b>MG4006</b>	6.0 <sup>[10]</sup>	4.5	4.5	1.0	0.001	PANG
	<b>MG5232</b>						
9380 — 9440	<b>MG5232F</b>	6.0	4.5	3.5	0.6	0.001	PNG
380 — 9440	<b>MG5255</b>	6.0 <sup>[11]</sup>	4.5	3.5	0.6	0.001	PNG
9380 — 9440	<b>MG5273</b>	6.0 <sup>[11]</sup>	4.5	3.5	0.6	0.001	PNG
9380 — 9440	<b>MG5389</b>	6.0	4.5	3.5	0.6	0.001	PNG
9345 — 9405	<b>MG5430</b> <sup>[12]</sup>	6.0	4.8	4.5	4.0	0.0001	PNG
9345 — 9405	<b>MG5496</b> <sup>[12]</sup>	6.0	4.7	4.0	4.0	0.0004	PANG
9380 — 9440	<b>MG5233</b>	8.0 <sup>[11]</sup>	4.4	5.0	0.75	0.0006	PNG
9415 — 9475	<b>MG5234</b>	8.0 <sup>[11]</sup>	4.4	5.0	0.75	0.0006	PNG
9345 — 9405	<b>MG5498</b> <sup>[12]</sup>	8.0	5.7	4.0	4.0	0.0004	PANG
9345 — 9405	<b>MG5253</b> <sup>[12]</sup>	10	5.5	4.5	2.5	0.001	PNG
9355 — 9395	<b>MG5254</b> <sup>[12]</sup>	12	5.9	5.75	3.5	0.00035	PNG
9355 — 9395	<b>MG5431</b>	12	5.9	5.75	3.5	0.00035	PNG
9380 — 9440	<b>MG4010</b> <sup>[10]</sup>	12.5	5.8	5.0	1.0	0.001	PANG
	<b>MG5241</b>						
9380 — 9440	<b>MG5241F</b>	12.5	5.8	5.0	1.0	0.001	PNG
9345 — 9405	<b>MG5244</b>	12.5 <sup>[11]</sup>	5.8	5.0	1.0	0.001	PANG
9345 — 9405	<b>MG5245</b>	12.5	5.8	5.0	1.0	0.001	PNG
9345 — 9405	<b>MG5256</b>	12.5 <sup>[11]</sup>	5.8	5.0	1.0	0.001	PANG
9380 — 9440	<b>MG5257</b>	12.5 <sup>[11]</sup>	5.8	5.0	1.0	0.001	PANG
9380 — 9440	<b>MG5258</b>	12.5 <sup>[11]</sup>	5.8	5.0	1.0	0.001	PANG
9380 — 9440	<b>MG5473</b>	12.5	5.8	5.0	1.0	0.001	PANG
9345 — 9405	<b>8356 (CV8505)</b> <sup>[12]</sup>	20 <sup>[11][14]</sup>	7.2	7.5	2.5	0.001	PANG
9265 — 9315	<b>MG5286</b> <sup>[13]</sup>	22.5 <sup>[14]</sup>	8.2	8.0	0.5	0.001	PAG

[10] Check with e2v technologies for availability

[11] Maintenance type

[12] Operable at high altitude

[13] Multipactor tuned

[14] Made to special order only

[15] Mechanically tuned over the specified frequency range

## PULSE MAGNETRONS - X-BAND CONTINUED

Fixed frequency types except where otherwise indicated

Frequency range (MHz)	Type	Peak output power (kW)	Typical operation				Class (see footnotes page 28)
			Peak anode voltage (kV)	Peak anode current (A)	Pulse duration ( $\mu$ s)	Duty cycle	
9620 — 9680	<b>M5068</b>	25	8.2	8.0	1.0	0.0005	PANG
9415 — 9460	<b>M5089T</b>	25	8.0	8.0	1.0	0.001	PANG
9380 — 9460 <sup>[15]</sup>	<b>M5149</b>	25 <sup>[14]</sup>	8.2	8.0	1.0	0.001	PANG
	<b>M5187</b>						
9380 — 9440	<b>M5187F</b>	25	8.2	8.0	1.0	0.0005	PANG
9330 — 9410 <sup>[15]</sup>	<b>MG5213</b>	25 <sup>[14]</sup>	8.2	8.0	1.0	0.001	PANG
9380 — 9440	<b>MG5218</b>	25 <sup>[11]</sup>	8.4	8.0	0.8	0.0007	PBNG
9345 — 9405	<b>MG5222</b>	25	8.2	8.0	1.0	0.001	PANG
9345 — 9405	<b>MG5222G</b>	25	8.2	8.0	1.0	0.001	PANG
9140 — 9200	<b>MG5230</b>	25	8.2	8.0	1.0	0.0005	PANG
9140 — 9200	<b>MG5230T</b>	25	8.0	8.0	1.0	0.001	PANG
9460 — 9520	<b>MG5231</b>	25	8.2	8.0	1.0	0.0005	PANG
9460 — 9520	<b>MG5231T</b>	25	8.0	8.0	1.0	0.001	PANG
9350 — 9400	<b>MG5239</b>	25	8.2	8.0	1.0	0.001	PANG
9345 — 9405	<b>MG5239T</b>	25	8.0	8.0	1.0	0.001	PANG
9380 — 9440	<b>MG5242</b>	25	8.2	8.0	1.0	0.0005	PANG
9380 — 9440	<b>MG5242T</b>	25	8.0	8.0	1.0	0.001	PANG
9380 — 9440	<b>MG5264</b>	25	8.2	8.0	1.0	0.0005	PANG
9345 — 9405	<b>MG5271</b>	25 <sup>[11]</sup>	8.4	8.0	0.8	0.0007	PBNG
9380 — 9440	<b>MG5424</b>	25	8.2	8.0	1.0	0.001	PANG
9380 — 9440	<b>MG5436</b>	25	8.2	8.0	1.0	0.001	PANG
9380 — 9440	<b>MG5437</b>	25	8.2	8.0	1.0	0.001	PANG
8870 — 8930	<b>MG5494</b>	25	8.2	8.0	1.0	0.001	PANG
9195 — 9255	<b>MG5497T</b>	25	8.0	8.0	1.0	0.001	PANG
9415 — 9460	<b>M5089</b>	30	8.3	9.0	1.0	0.0005	PANG
9415 — 9475	<b>M5199</b>	30	8.3	9.0	1.0	0.0005	PANG
9455 — 9495	<b>MG5265</b>	30	8.3	9.0	1.0	0.0005	PANG
	<b>M5005 (CV9424)<sup>[12]</sup></b>	53 <sup>[11]</sup>					
9345 — 9405	<b>M5005A<sup>[12]</sup></b>	53 <sup>[11]</sup>	13	12	4.0	0.0016	PAG
9440 — 9480	<b>M575B</b>	80 <sup>[11]</sup>	15	15	1.0	0.001	PAG
9380 — 9440	<b>M5188</b>	95 <sup>[11]</sup>	15	16	1.0	0.00085	PAG
9555 — 9645	<b>MAG21B</b>	130 <sup>[11]</sup>	17	20	0.25	0.001	PAG

S-band and X-band pulse magnetrons



[11] Maintenance type

[12] Operable at high altitude

[14] Made to special order only

## PULSE MAGNETRONS - KU(J)-BAND

Fixed frequency types except where otherwise indicated.

Frequency range (MHz)	Type	Peak output power (kW)	Typical operation			Class (see footnotes page 28)	
			Peak anode voltage (kV)	Peak anode current (A)	Pulse duration (ms)		
16.35 — 16.65	<b>MAG19<sup>[27]</sup></b>	35 <sup>[14]</sup>	11	10.5	0.5	0.001	PANG
16.2 — 17.4	<b>MG5323<sup>[16]</sup></b>	40 <sup>[14]</sup>	12	10	0.6	0.001	PABG
15 — 18	<b>MG5272<sup>[16]</sup></b>	50	14	11	0.5	0.001	PABG
16.2 — 17.4	<b>MG5387<sup>[17]</sup></b>	80 <sup>[14]</sup>	15	13	1.0	0.001	PAG

## PULSE MAGNETRONS - KA(Q)-BAND

Fixed frequency types except where otherwise indicated.

Centre frequency range (GHz)	Type	Peak output power (kW)	Typical operation				Class (see footnotes page 28)	
			Tuning range (MHz)	Peak anode voltage (kV)	Peak anode current (A)	Pulse duration (ns)		
33 — 37	<b>M5154<sup>[17]</sup></b>	1.3 <sup>[14]</sup>	—	4.0	1.5	400	0.0016	PBNG
33 — 37	<b>MG5280</b>	1.3 <sup>[14]</sup>	—	4.0	1.5	400	0.0016	PBNG
34.8 — 35.2	<b>MG5330<sup>[17]</sup></b>	2.0	—	4.1	3.0	100	0.0003	PBG
34.8 — 35.2	<b>MG5321<sup>[17]</sup></b>	10 <sup>[14]</sup>	—	8.0	7.0	100	0.001	PBG
34.4 — 35.4	<b>MG5492<sup>[18]</sup></b>	18	—	12	9.0	30	0.00045	PAG
34.51 — 35.21	<b>MG5328<sup>[18]</sup></b>	20	—	13.5	12	140	0.0005	PAG
34.75 — 35.25	<b>MG5438<sup>[18]</sup></b>	40	500 $\beta$	14	16	50	0.0004	PAG
34.5 — 35.5	<b>MG5301<sup>[18]</sup></b>	46	—	14.5	13	125	0.001	PAG
35.0	<b>MG5302<sup>[18]</sup></b>	46	300 $\beta$	14.5	13	125	0.001	PAG
35.0	<b>MG5303<sup>[18]</sup></b>	46	300 $\beta$	14.5	13	125	0.001	PAG
35.0	<b>MG5304<sup>[18]</sup></b>	46	300 $\beta$	14.5	13	125	0.0005	PAG
34.5 — 35.5	<b>MG5311</b>	50	270 $\epsilon$	14.5	14.5	200	0.0004	PAG
34.15	<b>MG5329<sup>[18]</sup></b>	60	300	15	16	50	0.0004	PAG

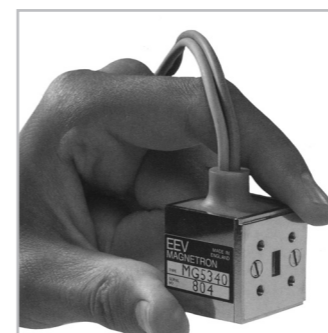

Miniature KA(Q)-Band pulse magnetron

[14] Made to special order only

[15] Mechanically tuned over the specified frequency range

[16] Coaxial magnetron

[17] Rugged

[18] Lightweight magnet

[19] Frequency agile

[20] Pulsed anode

[21] Precision tuned

[27] Quick heat cathode

## INJECTION-LOCKED MAGNETRONS — KU(J)-BAND

e2v technologies' expertise in high duty ratio magnetron and high power circulator technologies has been combined to produce a range of integrated magnetron/circulator units, suitable for operation as injection locked amplifiers, with low added phase noise and exceptional environmental tolerance.

The PLM5800 series phase locked magnetron amplifiers can be offered either as single magnetron/circulator matched assemblies, or in combination as enhanced gain amplifier chains.

These devices are small and lightweight, with fast warm-up (2 seconds typical), and are designed to withstand extreme vibration, shock and acceleration.

Typical ranges of characteristics available are:

Bandwidth (MHz)	Gain (dB)	Mean power (W)	Pulse duration (µs)	Duty cycle	Load VSWR	Temperature range (°C)	Added phase noise (dB/Hz)
50–150	10–23	10–100	0.5–5.0	0.25 max	2.0 max	-50 to +125	Better than -90

## MAGNETRON MODULATORS

Traditional high-power magnetron modulators have normally used Hydrogen Thyratrons (which continue to be available from e2v) as the switching device.

Innovation in the means of switching solid-state devices such as MOSFETs has allowed e2v to create a range of fully solid-state custom modulators for the linear accelerator and radar markets. These are characterised by the ability to control pulse length and inter-pulse period on a pulse-by-pulse basis. Excellent RF spectrum from the magnetron is ensured by careful control of the voltage rise and fall rates with positive current switch on and off. No lifed components are employed and means to confirm modulator integrity can be provided, maximising in service reliability.

In appropriate instances, designs can be offered which eliminate the need for a pulse transformer. Power supplies can also be incorporated.

Further details are available on request against specific requirements.

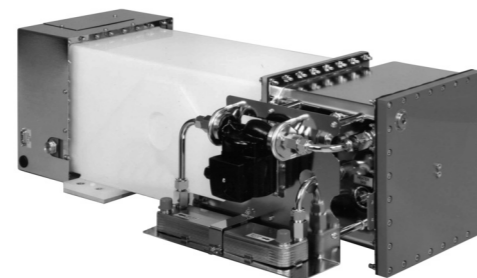

solid-state magnetron modulator

## BROADBAND CW TRAVELLING WAVE TUBES FOR ECM

Increased bandwidth, efficiency and gain are characteristic of this range, which extends from 4.5 to 18 GHz.

The rugged construction of these tubes ensures stable performance with high reliability when operated under severe environmental conditions. Beam switching is achieved by means of a focus electrode. This range includes small lightweight miniature TWTs ideal for a variety of demanding ECM applications including decoy systems.



Broadband CW Travelling Wave Tube for ECM

Frequency range (GHz)	Type	Output power (W)	Gain (dB)	Helix voltage (kV)	Collector to Cathode Voltage (kV)	Collector Current (mA)	Output Connector	Weight (kg)
6–18	<b>N10173</b> <sup>[24]</sup>	75–120	39–57	4.55	2.45/1.58	200	TNC	0.6
6–18	<b>N10137</b> <sup>[24]</sup>	60–110	37–52	4.55	2.7/1.86	200	SMA	0.6
4.5–10 <sup>[11]</sup>	<b>N1078</b>	1.5	37	2.0	2.0	25	SMA	0.9
4.5–10 <sup>[11]</sup>	<b>N1077</b>	1.5	27	5.8	3.2	210	TNC	3.6
4.5–18	<b>N10122</b> <sup>[24]</sup>	25–140	30–50	4.55	2.4/1.5	200	SMA	0.6
4.5–18	<b>N10122A§</b> <sup>[24]</sup>	25–125	30–50	4.55	2.7/1.86	200	SMA	0.6
4.5–18	<b>N10122B§</b> <sup>[24]</sup>	25–100	20–35	4.55	2.7/1.86	200	SMA	0.6
6–18	<b>N10128</b>	75–120	35–55	4.5	2.3	200	SMA	0.6
6–18	<b>N10110</b>	180–260	40–65	6.2	3.6	285	SMA, WRD650	1.4
8–16.5 <sup>[11]</sup>	<b>N1081</b>	100	30	7.1	4.2	210	Waveguide	3.4
7–18 <sup>[11]</sup>	<b>N1082</b>	0.5	34	2.0	2.0	20	SMA	0.7
8–18	<b>N10091</b> <sup>[24]</sup>	270 min.	35	9.2	4.6	420	SMA, WRD750	5.5

## BROADBAND CW TRAVELLING WAVE TUBES FOR DECOY SYSTEMS

Wide and ultra wide band robust mini travelling wave tubes, supplied in unpackaged form for incorporation into décor and other expendable of multi use applications where pace is at a premium. Designs can be tailored to fit within specific platform constraints.

These tubes are characterised by their ability to withstand extremes of temperature, shock and vibration, making them eminently suitable for use in these demanding military applications.

4.5–18	<b>N10171</b> <sup>[24]</sup>	25–140	30–50	4.55	2.4/1.5	200	SMA	0.6
6–18	<b>N10167</b> <sup>[24]</sup>	75–125	39–57	4.55	2.45/1.58	200	SMA	0.6
4.5–18	<b>N10122A</b> <sup>[23] [24]</sup>	25–125	30–50	4.55	2.7/1.86	200	SMA	0.6
4.5–18	<b>N10122B</b> <sup>[23] [24]</sup>	25–100	20–35	4.55	2.7/1.86	200	SMA	0.6

## BROADBAND CW TRAVELLING WAVE TUBE CHAINS FOR ECM

Each chain consists of two tubes combined with other microwave components to form a single high gain unit of relatively short length. A range of modulation facilities can be included. The use of a TWT for the driver stage eliminates the

need for high gain in the output tube, giving reduced noise output under certain operational conditions. Chains can be configured to provide optimum performance for specific customer requirements.

Frequency (GHz)	Type	Output power (W)	Drive Tubes	Collector to Cathode power (dBm)	Collector Cathode Voltage (kV)	Current (mA)	RF connectors
4.5 – 10	<b>N10500</b>	150	N1078 drive N1077 output	-13	2.0	21	SMA input TNC output
8 – 16.5	<b>N10501</b>	150	N1082 drive N1081 output	-14	2.1	16	SMA input WG output

[11] Maintenance type

[22] Not recommended for new equipment

[23] Focus electrode switched

[24] High efficiency two-stage depressed collector

## PULSED COUPLED-CAVITY TRAVELLING WAVE TUBES FOR RADAR

The range consists of tubes of rugged metal/ceramic construction, designed for mobile military environments. They employ high  $\mu$  shadow grid modulation suitable for modern multi-function radars.

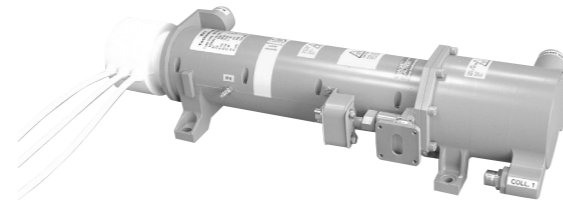

X-Band, 20kW Pulsed Coupled Cavity TWT

Frequency range (GHz)	Type	Peak output power (kW min.)	Duty cycle	Gain (dB typ.)	voltage (kV typ.)	current (A typ.)	Beam Focus system	Beam Cooling
5.25-5.85	<b>N10563</b> <sup>[24]</sup>	70	0.02	52	38	9.5	PPM	Liquid
5.25-5.85	<b>N10575</b> <sup>[24]</sup>	70	0.02	52	38	9.5	PPM	Liquid
5.4-5.9	<b>N10524</b>	50	0.024	51	31	9.0	PPM	Liquid
X-Band	<b>N10559</b> <sup>[24]</sup>	10	0.10	43	22	3.2	PPM	Liquid
X-Band	<b>N10543</b>	15	0.035	55	24	3.8	PPM	Liquid
X-Band	<b>N10570A</b>	20	0.0825	42	25	4.0	PPM	Liquid
8.6-9.5	<b>N10503C</b>	25	0.01	50	25	6.0	PPM	Forced-air
X-Band	<b>N10502</b>	50	0.015	42	31	7.5	PPM	Liquid
8.6-9.6	<b>N10530</b>	50	0.0015	42	32	7.5	PPM	Liquid
X-Band	<b>N10555</b>	50	0.015	50	32	7.5	PPM	Forced-air
16.5-17	<b>N10517</b> <sup>[24]</sup>	12	0.025	45	29.5	2.0	PPM	Liquid
35	<b>N10544</b>	4.5	0.035	48	37	1.25	PPM	Forced-air

## HELIX PULSED TRAVELLING WAVE TUBES FOR RADAR

Pulsing of the higher power tubes in this range is achieved by means of precision-manufactured shadow grids. Low close-to-carrier noise, essential in modern pulse Doppler radars, is ensured by rugged gun construction which maintains grid-cathode spacing within close limits under extreme operating conditions.

Frequency range (GHz)	Type	Peak output power (W)	Duty cycle	Gain (dB)	Collector to cathode voltage (kV)	Collector current (mA)	RF connector	Cooling
4.4-5.8	<b>N1094</b>	270	0.05	40	3.4	370	SMA	Conduction
8-10	<b>N10099</b>	1200	0.02	47	11.0	830	TNC	Conduction
9-10.5	<b>N10011</b> <sup>[25]</sup>	900	0.5	51	5.5	740	Waveguide	Conduction
		220	1.0	30	5.5	300		

<sup>[24]</sup> High resistivity water cooling; contact e2v technologies for details

<sup>[25]</sup> Low resistivity water cooling; contact e2v technologies for details

[24] High efficiency two-stage depressed collector

[25] Dual mode tube, pulsed and CW

## TRAVELLING WAVE TUBES FOR SATELLITE GROUND STATIONS AND TERRESTRIAL COMMUNICATIONS

Rugged helix construction and conservative cathode ratings combine with other design features to give a range of tubes capable of long reliable life in both fixed and transportable systems. Where a value is not quoted for the noise figure, contact e2v technologies for more information.

Frequency range (GHz)	Output power (W)	Type	Gain (dB)	Noise factor (dBc)	Collector to cathode voltage (kV)	Collector current (mA)	RF connectors	Cooling
7.9-8.4	60	<b>N10025</b> <sup>[24]</sup>	34	-28	2.1/1.5	49/43	SMA, waveguide	Conduction
12.75-14.5	300	<b>N10130A</b>	36	-35	4.8	320	SMA, WG17	Forced-air <sup>[26]</sup>
12.75-14.5	350	<b>N10131</b>	36	—	4.3	300	SMA, WG17	Forced-air
12.75-14.5	500	<b>N10151</b>	36	—	4.3	380	SMA, WG17	Forced-air
5.85-6.425	100		30					
7.9-8.4	140		38					
13.75-14.5	95	<b>N10125T</b>	32	—	3.0	220	SMA, WRD580	Forced-air
13.75-14.5	150	<b>N10125</b>	44	—	3.2	230	SMA, WG17	Forced-air
13.75-14.5	350	<b>N10132</b>	36	—	4.3	300	SMA, WG17	Forced-air
13.75-14.5	500	<b>N10152</b>	36	—	4.3	380	SMA, WG17	Forced-air
14-14.5	350	<b>N10130</b>	36	-35	4.3	300	SMA, WG17	Forced-air <sup>[26]</sup>
14-14.5	500	<b>N10101</b>	38	-35	4.6	400	SMA, WG18	Conduction
14-14.5	500	<b>N10150</b>	36	-35	4.3	380	SMA, WG17	Forced-air <sup>[26]</sup>

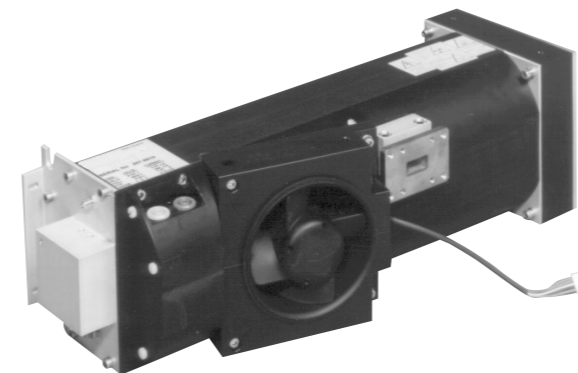

500W, 14-14.5 GHz Communication TWT

[24] High efficiency two-stage depressed collector

[26] Includes tube mount and cooling fans