

PERFORMANCE

Range	0 - 20 ppm
Maximum overload.....	250 ppm
Sensitivity (see note).....	450 - 750 nA/ppm NO2
Zero in air at 20 °C.....	<0.9 ppm NO2
Resolution.....	0.1 ppm NO2
Linearity	linear across range
Response time, t90	<35 s
Long-term output drift.....	<2% signal/month
Warranty	2 years

Note: This output current is negative. This is because the sensor reaction is a reduction of the target gas.

OPERATING CONDITIONS

Temperature range	-20 to +50 °C
Operating humidity.....	15 - 90% RH (non-condensing)
Pressure range	90 - 110 kPa (nominal)
Operating circuit.....	see Electrochemical Toxic Sensor Application Note
Applied potential	0 V
Storage life.....	6 months in original packaging (0 - 25 °C)

PHYSICAL CHARACTERISTICS

Label colour	silver
Weight.....	5 g approx.
Dimensions	see outline

This device is designed to be RoHS compliant.

CROSS-SENSITIVITY DATA

GAS	Concentration (ppm)	Sensor Response (As ppm NO2)
Carbon Monoxide	300	0
Hydrogen Sulfide	15	-1.2
Sulfur Dioxide	5	-5
Nitric Oxide	35	0
Chlorine	1	-1

Important Note

Do not solder to the connector pins as this may damage the sensor and thereby invalidate the warranty.

Details on recommended connector pins can be found in the Frequently Asked Questions within the Gas Sensor section of the e2v website.

OUTLINE

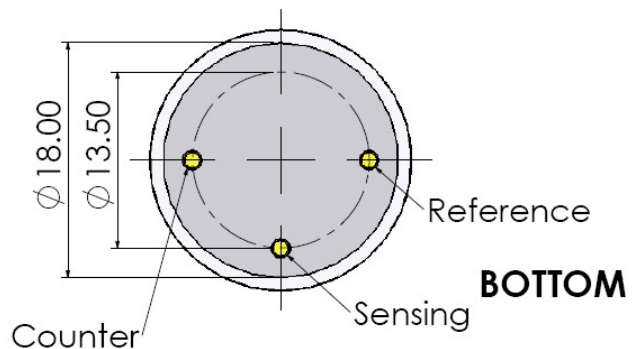
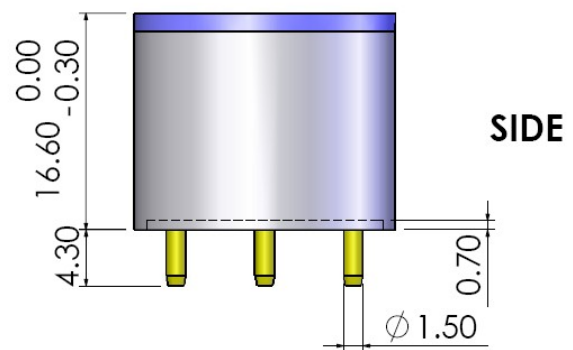
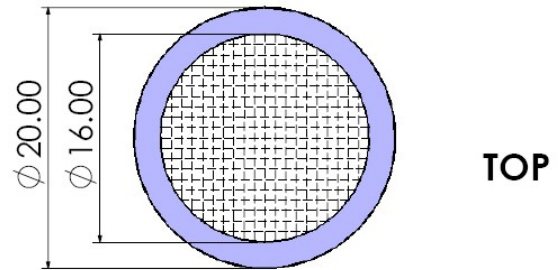

All dimensions in mm.
All tolerances ± 0.15 mm unless otherwise stated.

Whilst e2v technologies has taken care to ensure the accuracy of the information contained herein it accepts no responsibility for the consequences of any use thereof and also reserves the right to change the specification of goods without notice. e2v technologies accepts no liability beyond the set out in its standard conditions of sale in respect of infringement of third party patents arising from the use of tubes or other devices in accordance with information contained herein.

e2v technologies (uk) limited, Waterhouse Lane, Chelmsford, Essex CM1 2QU United Kingdom Telephone: +44 (0)1245 493493 Facsimile: +44 (0)1245 492492

e-mail: enquiries@e2v.com Internet: www.e2v.com Holding Company: e2v technologies plc

e2v technologies inc. 520 White Plains Road, Suite 450, Tarrytown, NY10591 USA Telephone: (914) 592-6050 Facsimile: (914) 592-5148 e-mail: enquiries@e2vtechnologies.us

TEMPERATURE DEPENDENCE

EC4-20-NO2 Graph of Zero vs Temperature

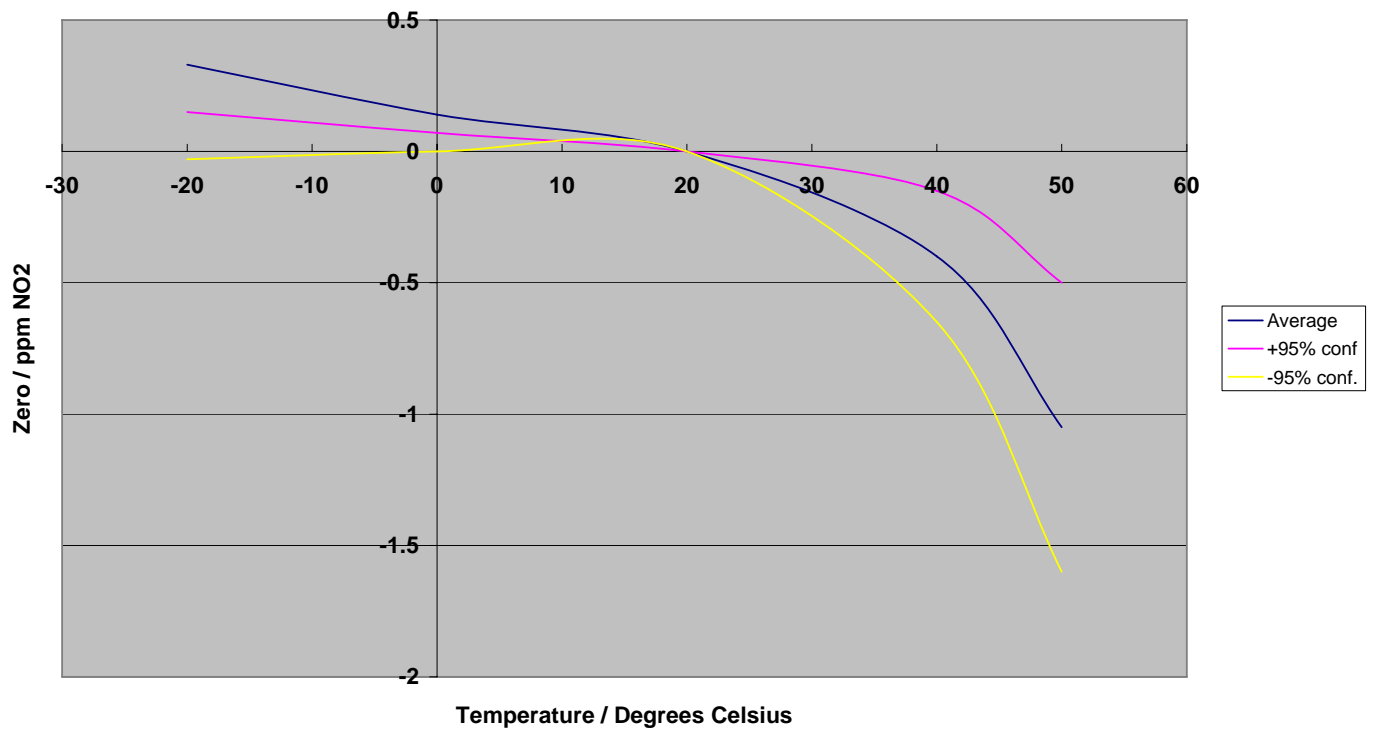

EC4-20-NO2 Graph of Sensitivity vs Temperature

