

This datasheet describes the use of the MiCS-2614 in ozone detection applications. The package and the mode of operation described in this document target the detection of the oxidising gas O₃ in indoor or outdoor environments. Ozone is a hazardous gas, which can cause respiratory problems at concentrations above 100 ppb.

FEATURES

- Low heater current
- Wide detection range
- High sensitivity
- Fast thermal response
- Miniature dimensions
- High resistance to shocks and vibrations

IMPORTANT PRECAUTIONS

Read the following instructions carefully before using the MiCS-2614 sensor described in this document to avoid erroneous readings and to prevent the device from permanent damage.

- The sensor must not be wave soldered without protection, or exposed to high concentrations of organic solvents, ammonia, or silicone vapours, to avoid poisoning the sensitive layer.
- Heating powers above the maximum rating of 95 mW can destroy the sensor due to overheating.
- After exposing the sensor to high concentrations of O₃, make sure the sensor is given enough time to recover before taking new measurements.
- For any additional questions, email enquiries@e2v.com or telephone +44 (0)1245 493493.

OPERATING MODE

The recommended mode of operation is a constant voltage mode. A heater power of P_H = 80 mW is applied. This causes the temperature of the sensing resistor (R_S) to reach about 430 °C.

Detection of the O₃ concentration is achieved by measuring the sensing resistor R_S during operation.

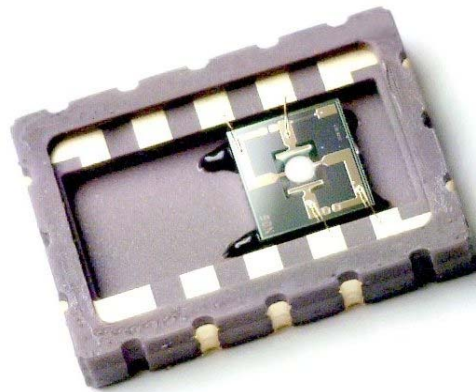

Product shown without cap

SENSOR CONFIGURATION

The silicon gas sensor structure consists of an accurately micro machined diaphragm with an embedded heating resistor and the sensing layer on top.

The internal connections are shown below.

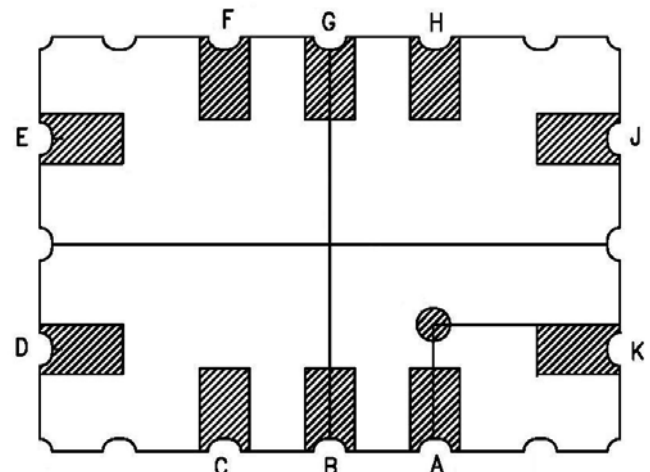

Pin	Connection
A	
B	
C	Rh1
D	Rs1
E	
F	Rh2
G	Rs2
H	
J	
K	

R_s: sensor resistance
R_h: heater resistance

Fig. 1: MiCS-2614 configuration (bottom view).

Whilst e2v technologies has taken care to ensure the accuracy of the information contained herein it accepts no responsibility for the consequences of any use thereof and also reserves the right to change the specification of goods without notice. e2v technologies accepts no liability beyond the set out in its standard conditions of sale in respect of infringement of third party patents arising from the use of tubes or other devices in accordance with information contained herein.

e2v technologies (uk) limited, Waterhouse Lane, Chelmsford, Essex CM1 2QU United Kingdom Telephone: +44 (0)1245 493493 Facsimile: +44 (0)1245 492492

e-mail: enquiries@e2v.com Internet: www.e2v.com Holding Company: e2v technologies plc

e2v technologies inc. 520 White Plains Road, Suite 450, Tarrytown, NY10591 USA Telephone: (914) 592-6050 Facsimile: (914) 592-5148 e-mail: enquiries@e2vtechnologies.us

POWER CIRCUIT EXAMPLE

As shown below, one external load resistor can be used to power the heater with a single 5 V power supply.

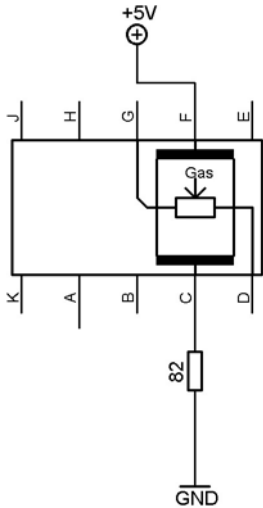

Figure 2: MiCS-2614 with recommended supply circuit (top view)

R is 82 Ω. This resistor is necessary to obtain the right temperature on the heater while using a single 5 V power supply. The resulting voltage is typically $V_H = 2.35$ V.

MEASUREMENT CIRCUIT EXAMPLE

As shown below, the sensitive resistance shall be read by using a load resistor.

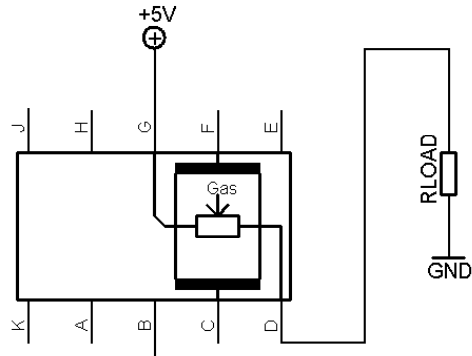

Figure 3: MiCS-2614 with measurement circuit (top view)

The voltage measured on the load resistor is directly linked to the resistance of the sensor. RLOAD must be 820 Ω at the lowest in order not to damage the sensitive layer.

SENSOR CHARACTERISTICS

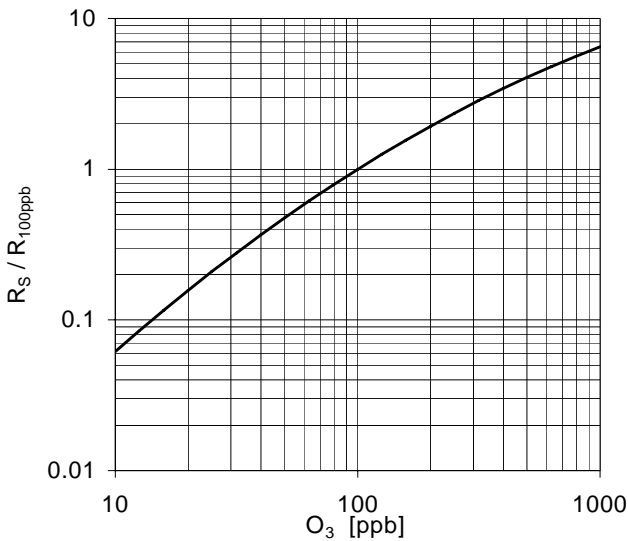

Fig. 4: R_s/R_0 as a function of gas concentration at 50% RH and 25 °C.

ELECTRICAL CHARACTERISTICS

Rating	Symbol	Value/Range	Unit
Maximum heater power dissipation (see note 1)	P_H	95	mW
Maximum sensitive layer power dissipation	P_S	1	mW
Voltage supply	V_{supply}	4.9 – 5.1	V
Relative humidity range	R_H	5 – 95	%RH
Ambient operating temperature	T_{amb}	-40 – 70	°C
Storage temperature range (see note 2)	T_{sto}	-40 – 50	°C
Storage humidity range	RH_{sto}	5 - 95	%RH

OPERATING CONDITIONS

Parameter	Symbol	Typ	Min	Max	Unit
Heating power (see note 3)	P_H	80	66	95	mW
Heating voltage	V_H	2.35	-	-	V
Heating current	I_H	34	-	-	mA
Heating resistance at nominal power (see note 4)	R_H	68	58	78	Ω

SENSITIVITY CHARACTERISTICS

Characteristic	Symbol	Typ	Min	Max	Unit
O ₃ detection range	FS		10	1000	ppm
Sensing resistance in air	R_0	11	3	60	k Ω
Sensitivity factor (see note 5)	S_R	2	1.5	4	-

Notes:

1. Heating powers above 95 mW can cause permanent damage to the sensor due to overheating.
2. Storage of parts in original shipping package.
3. To ensure a correct operating temperature, the heater voltage should be adjusted so that the resulting heating power equals 80 mW. Lower heating power will reduce the sensitivity and increase the response time. Heating powers above 95 mW can cause permanent damage to the sensor due to overheating.
4. Heating resistor values from sensors out of production range between 58 and 78 Ω measured at $V_H = 2.35V$. Due to material properties of the heating resistor its value increases during operating life.
5. Sensitivity factor S_R is defined as R_s at 100 ppb of O₃ divided by R_s at 50 ppb of O₃. Test conditions are 50 ± 5% RH and 25 ± 2 °C.

PACKAGE OUTLINE

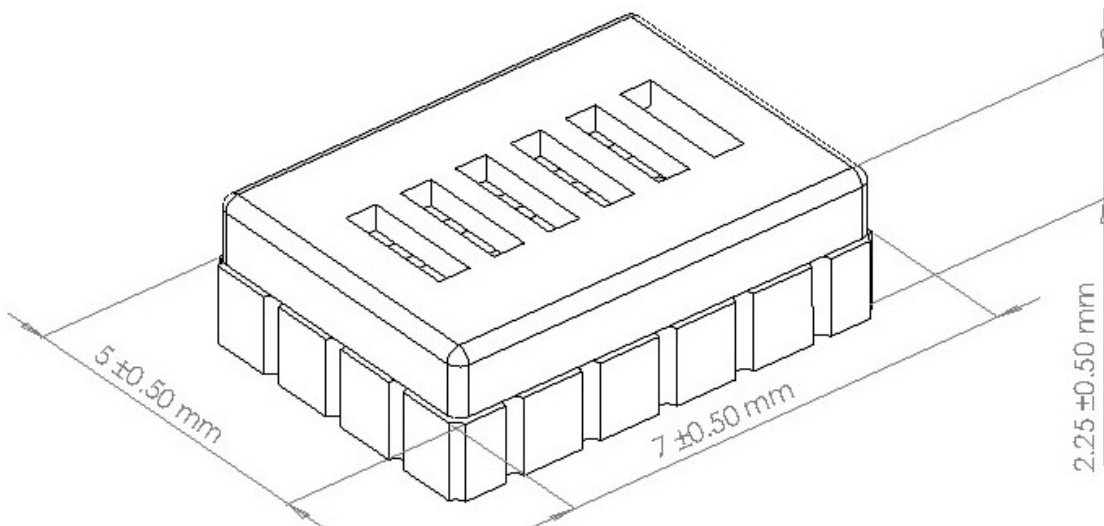

SOLDERING PADS GEOMETRY

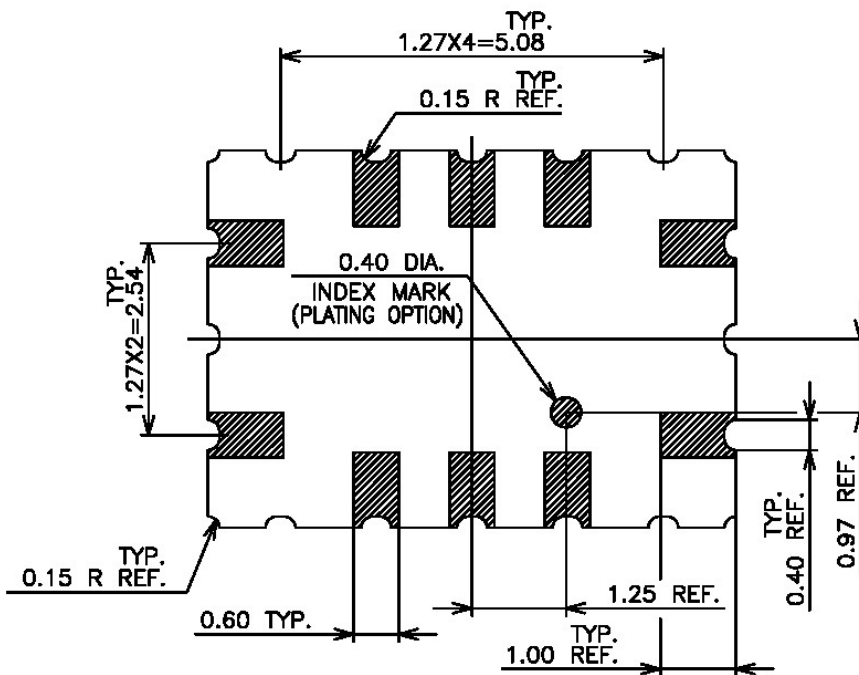

e2v semiconductor gas sensors are well suited for leak detection and applications requiring limited accuracy. Their use for absolute gas concentration detection is more complicated because they typically require temperature compensation, calibration, and sometimes as well, humidity compensation. Their base resistance in clean air and their sensitivity can vary overtime depending on the environment they are in. This effect must be taken into account for any application development (1087-1.1).