

Description

ZXGD3006E6 is a 40V Gate Driver for switching IGBTs and SiC MOSFETs. It can transfer up to 10A peak source/sink current into the gate for effective charging and discharging of a large capacitive load.

The ZXGD3006E6 can drive typically 4A into the low gate impedance of an IGBT, with just 1mA input from a controller. Also, the turn-on and turn-off switching behavior of the IGBT can be individually tailored to suit an application. In particular, by defining the switching characteristics appropriately, EMI and cross conduction problems can be reduced.

Applications

Gate driving IGBTs and SiC MOSFETs in:

- Solar inverters
- Power supplies
- Plasma display panel power modules
- DC-DC converters in electric cars

Features

- High-gain buffer with typically 4A output from 1mA input
- 40V supply for +20V to -18V gate driving to prevent dV/dt induced false triggering
- Emitter-follower that is rugged to latch-up / shoot-through issues, and delivers <10ns propagation delay time
- Separate source and sink outputs for independent control of IGBT turn-on and turn-off times
- Optimized pin-out to simplify PCB layout and reduce parasitic trace inductances
- Near-zero quiescent supply current
- **Totally Lead-Free & Fully RoHS compliant (Notes 1 & 2)**
- **Halogen and Antimony free. "Green" Device (Note 3)**
- **Qualified to AEC-Q101 Standards for High Reliability**
- **PPAP capable (Note 4)**

Mechanical Data

- Case: SOT26
- Case material: molded plastic. "Green" molding compound.
- UL Flammability Rating 94V-0
- Moisture Sensitivity: Level 1 per J-STD-020
- Terminals: Finish - Matte Tin Plated Leads, Solderable per MIL-STD-202, Method 208
- Weight: 0.018 grams (approximate)

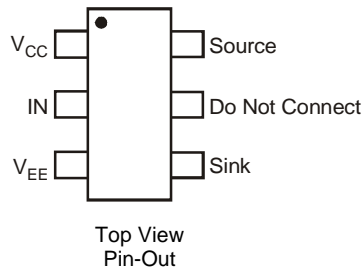

Pin Name	Pin Function
V _{CC}	Supply voltage high
IN	Driver input pin
V _{EE}	Supply voltage low
SOURCE	Source current output
SINK	Sink current output

Ordering Information (Notes 4 & 5)

Product	Compliance	Marking	Reel size (inches)	Tape width (mm)	Quantity per reel
ZXGD3006E6TA	AEC-Q101	3006	7	8	3000
ZXGD3006E6QTA	Automotive	3006	7	8	3000

- Notes:
1. No purposely added lead. Fully EU Directive 2002/95/EC (RoHS) & 2011/65/EU (RoHS 2) compliant.
 2. See <http://www.diodes.com> for more information about Diodes Incorporated's definitions of Halogen and Antimony free, "Green" and Lead-Free.
 3. Halogen and Antimony free "Green" products are defined as those which contain <900ppm bromine, <900ppm chlorine (<1500ppm total Br + Cl) and <1000ppm antimony compounds.
 4. Automotive products are AEC-Q101 qualified and are PPAP capable. Automotive, AEC-Q101 and standard products are electrically and thermally the same, except where specified.
 5. For packaging details, go to our website at <http://www.diodes.com>

Marking Information

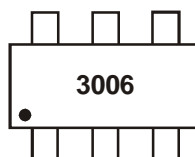

3006 = Product Type Marking Code

Typical Application Circuit

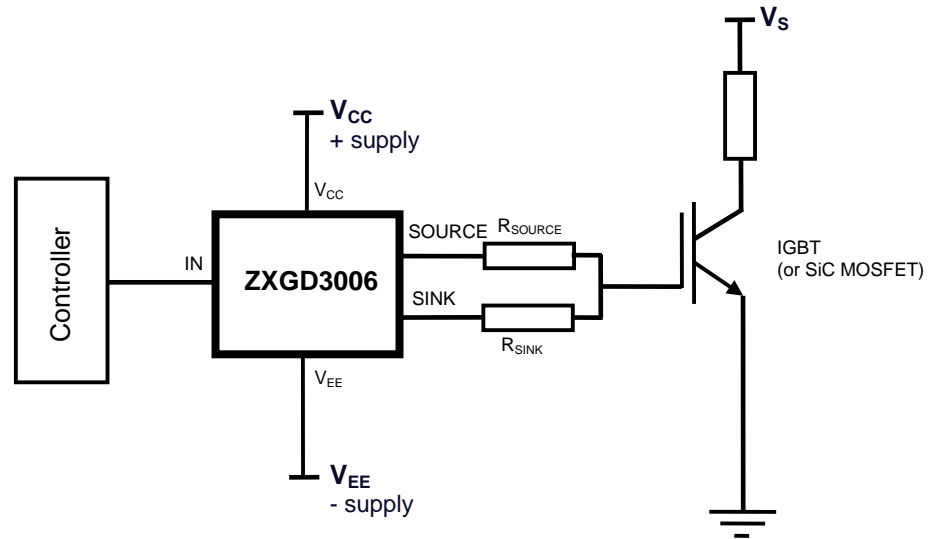

Maximum Ratings (@T_A = +25°C, unless otherwise specified.)

Characteristic	Symbol	Value	Unit
Supply voltage, with respect to V _{EE}	V _{CC}	40	V
Input voltage, with respect to V _{EE}	V _{IN}	40	V
Output difference voltage (Source – Sink)	ΔV _(source-sink)	±7.5	V
Peak output current	I _{PK}	±10	A
Input current	I _{IN}	±100	mA

Thermal Characteristics (@T_A = +25°C, unless otherwise specified.)

Characteristic	Symbol	Value	Unit
Power Dissipation (Notes 6 & 7)	P _D	1.1	W
Linear derating factor		8.8	mW/°C
Thermal Resistance, Junction to Ambient (Notes 6 & 7)	R _{θJA}	113	°C/W
Thermal Resistance, Junction to Lead (Note 8)	R _{θJL}	105	
Operating and Storage Temperature Range	T _J , T _{STG}	-55 to +150	°C

- Notes:
6. For a device surface mounted on 25mm x 25mm x 0.6mm FR4 PCB with high coverage of single sided 1oz copper, in still air conditions; the device is measured when operating in a steady-state condition. The heatsink is split in half with the pin 1 (V_{CC}) and pin 3 (V_{EE}) connected separately to each half.
 7. For device with two active die running at equal power.
 8. Thermal resistance from junction to solder-point at the end of each lead on pin 1 (V_{CC}) and pin 3 (V_{EE}).

Electrical Characteristics (@T_A = +25°C, unless otherwise specified.)

Characteristic	Symbol	Min	Typ	Max	Unit	Test Condition
Output voltage, high	V _{OUT(hi)}	V _{CC} - 1.0	V _{CC} - 0.8	-	V	V _{IN} = V _{CC} C _L = 1nF
Output voltage, low	V _{OUT(low)}	-	V _{EE} + 0.12	V _{EE} + 0.3		V _{IN} = V _{EE} R _{SOURCE} = 0Ω, R _{SINK} = 0Ω
Supply breakdown voltage	BV _{CC}	40	-	-	V	I _Q = 100μA, V _{IN} = V _{CC}
		40	-	-		I _Q = 100μA, V _{IN} = V _{EE} = 0V
Quiescent supply current	I _Q	-	-	50	nA	V _{CC} = 30V, V _{IN} = V _{CC}
		-	-	50		V _{CC} = 30V, V _{IN} = V _{EE} = 0V
Source current	I _(source)	-	4.0	-	A	V _{CC} = 5V, I _{IN} = 1mA, V _{OUT} = 0V
Sink current	I _(sink)	-	3.8	-		V _{CC} = 5V, I _{IN} = -1mA, V _{OUT} = 5V
Source current with varying input resistances	I _(source)	-	6.4	-	A	V _{CC} = 15V, V _{EE} = 0V V _{IN} = 15V C _L = 100nF, R _L = 0.18Ω R _{SOURCE} = 0Ω, R _{SINK} = 0Ω
			5.5			
			3.9			
			2.2			
			0.44			
Sink current with varying input resistances	I _(sink)	-	7.7	-	A	V _{CC} = 15V, V _{EE} = 0V V _{IN} = 15V C _L = 100nF, R _L = 0.18Ω R _{SOURCE} = 0Ω, R _{SINK} = 0Ω
			6.5			
			4.4			
			2.3			
			0.46			
Switching times with low load capacitance C _L = 10nF	t _{d(rise)} t _r t _{d(fall)} t _f	-	8	-	ns	V _{CC} = 15V, V _{EE} = 0V V _{IN} = 0 to 15V R _{IN} = 1kΩ C _L = 10nF, R _L = 0.18Ω R _{SOURCE} = 0Ω, R _{SINK} = 0Ω
			48			
			16			
			35			
Switching times with high load capacitance C _L = 100nF	t _{d(rise)} t _r t _{d(fall)} t _f	-	46	-	ns	V _{CC} = 15V, V _{EE} = 0V V _{IN} = 0 to 15V R _{IN} = 1kΩ C _L = 100nF, R _L = 0.18Ω R _{SOURCE} = 0Ω, R _{SINK} = 0Ω
			419			
			47			
			467			
Switching times with asymmetric source and sink resistors	t _{d(rise)} t _r t _{d(fall)} t _f	-	27	-	ns	V _{CC} = 20V, V _{EE} = -18V V _{IN} = -18 to 20V R _{IN} = 1kΩ C _L = 10nF, R _L = 0.18Ω R _{SOURCE} = 4.7Ω, R _{SINK} = 0Ω
			208			
			11			
			53			

Switching Test Circuit and Timing Diagram

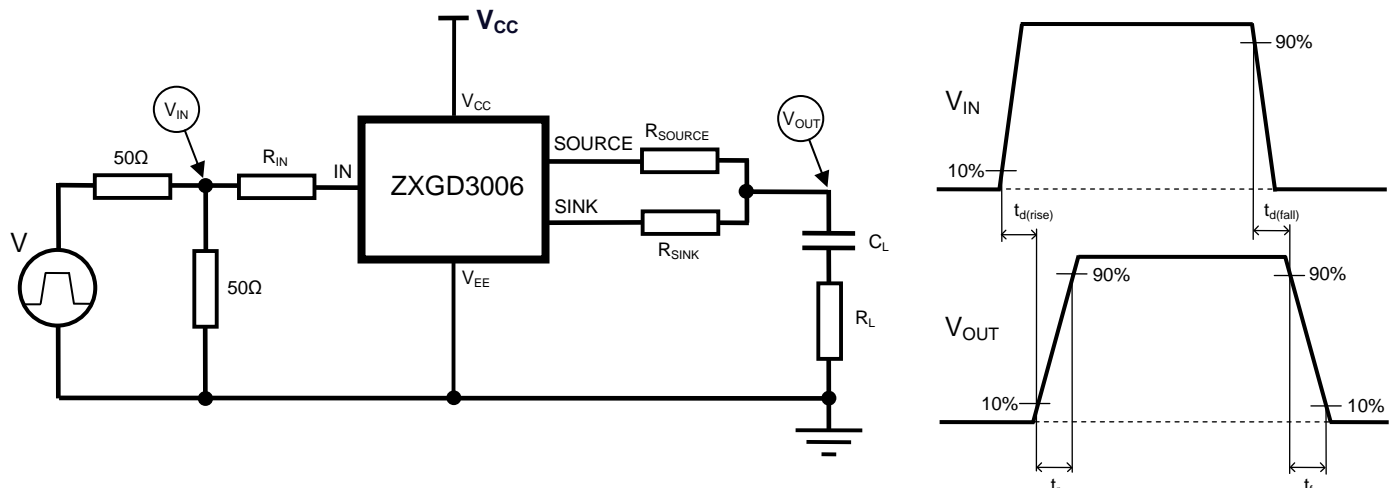

Typical Switching Characteristics (@T_A = +25°C, unless otherwise specified.)

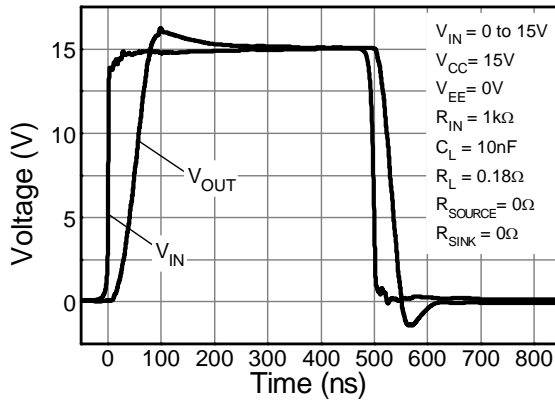

Switching Speed
Low Load Capacitance $C_L = 10\text{nF}$

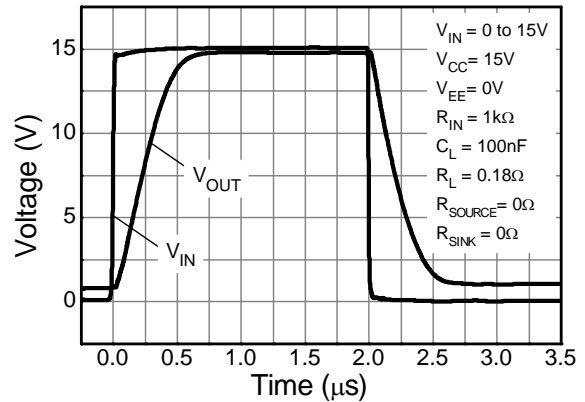

Switching Speed
High Load Capacitance $C_L = 100\text{nF}$

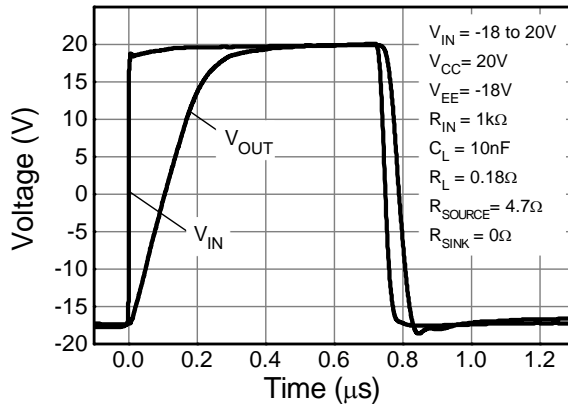

Switching Speed
Asymmetric Source and Sink Resistors

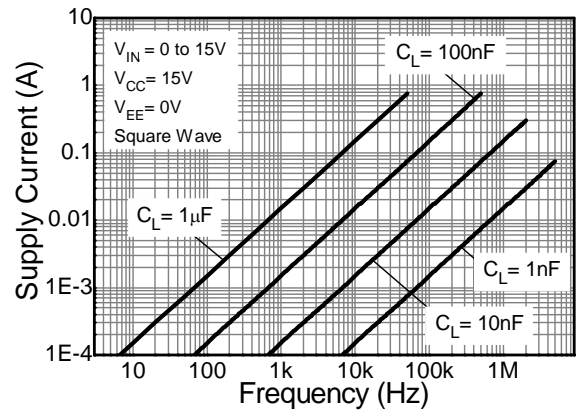

Supply Current

Typical Switching Characteristics (@ $T_A = +25^\circ\text{C}$, unless otherwise specified.)

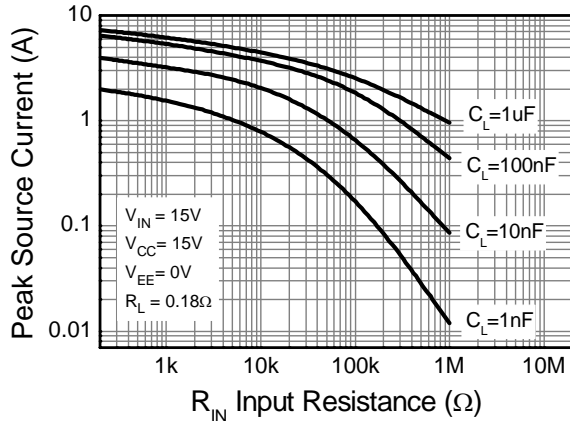

Source Current vs. Input Resistance

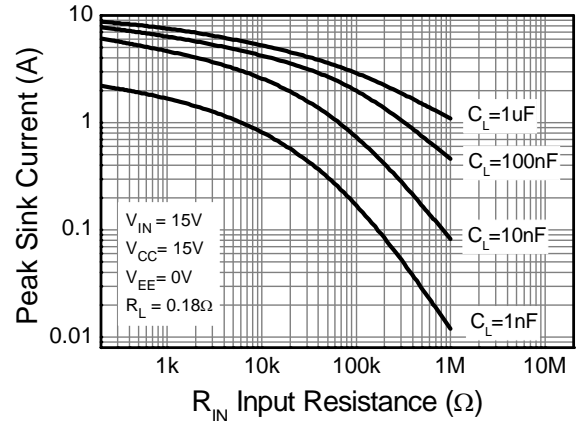

Sink Current vs. Input Resistance

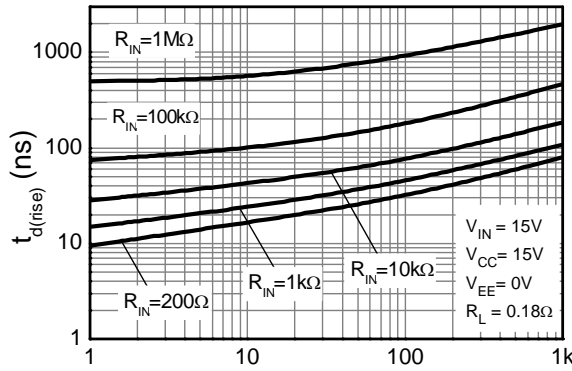

Turn-On Delay Time

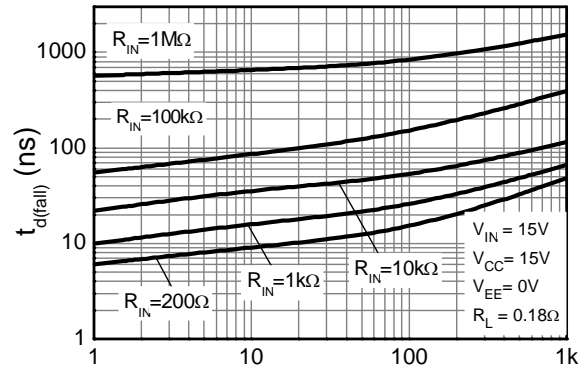

Turn-Off Delay Time

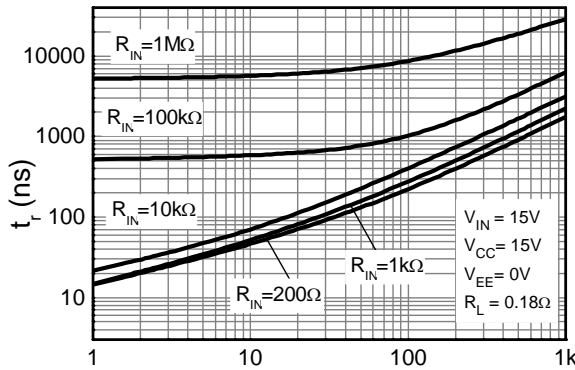

Turn-On Rise Time

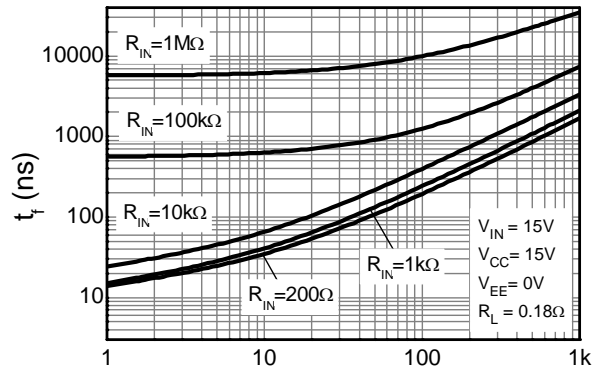

Turn-Off Fall Time

Circuit Examples

ZXGD3006 driving a MOSFET

Application example of the ZXGD3006 driving the gate of a MOSFET from 0 to +15V with $R_{SOURCE} = R_{SINK} = 0\Omega$

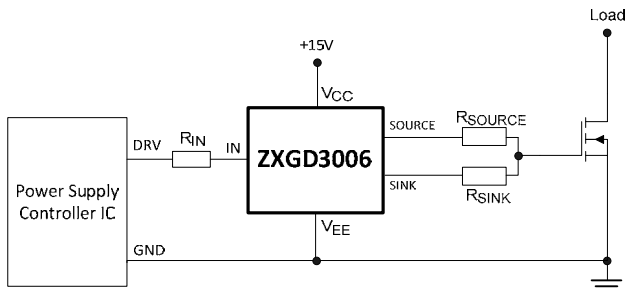

Switching Time Characteristic

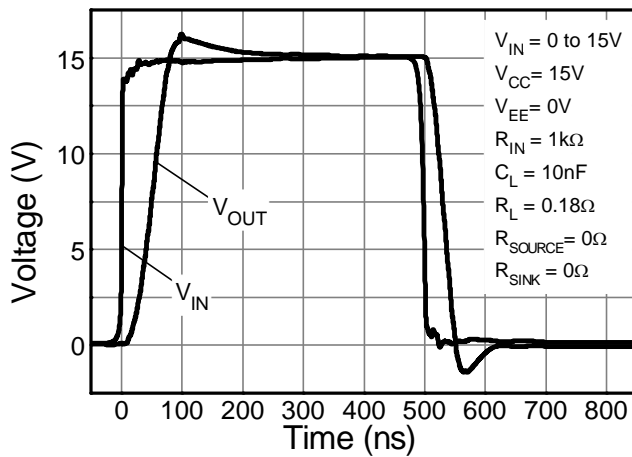

Symmetric Source and Sink Resistors

ZXGD3006 driving an IGBT

Application example of ZXGD3006 driving the gate of an IGBT with independent t_{on} and t_{off} using asymmetric R_{SOURCE} and R_{SINK} . In addition, the gate is driven negative to -18V to prevent dV/dt induced false triggering.

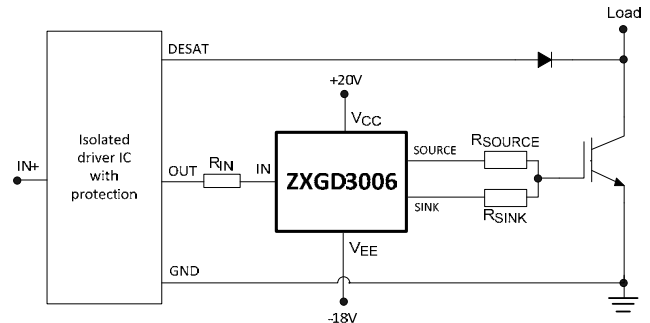

Switching Time Characteristic

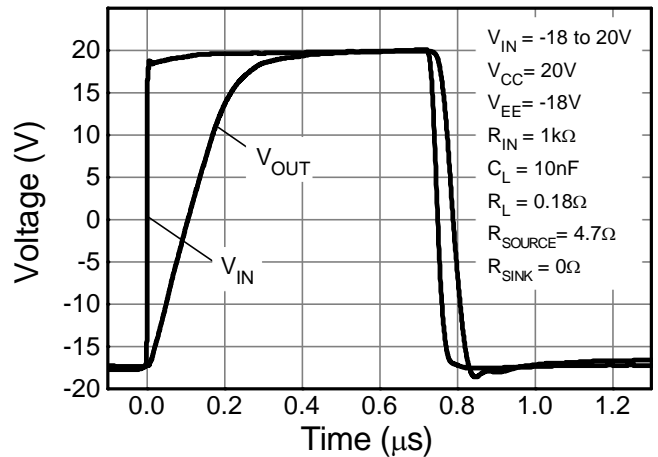

Asymmetric Source and Sink Resistors

Package Outline Dimensions

Please see AP02002 at <http://www.diodes.com/datasheets/ap02002.pdf> for latest version.

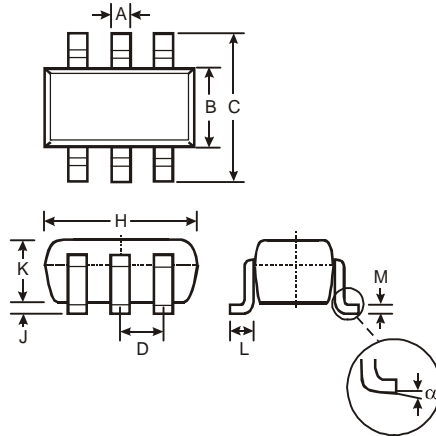

SOT26			
Dim	Min	Max	Typ
A	0.35	0.50	0.38
B	1.50	1.70	1.60
C	2.70	3.00	2.80
D	—	—	0.95
H	2.90	3.10	3.00
J	0.013	0.10	0.05
K	1.00	1.30	1.10
L	0.35	0.55	0.40
M	0.10	0.20	0.15
α	0°	8°	—
All Dimensions in mm			

Suggested Pad Layout

Please see AP02001 at <http://www.diodes.com/datasheets/ap02001.pdf> for the latest version.

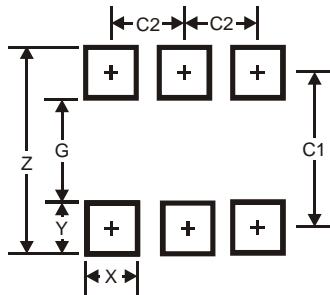

Dimensions	Value (in mm)
Z	3.20
G	1.60
X	0.55
Y	0.80
C1	2.40
C2	0.95

IMPORTANT NOTICE

DIODES INCORPORATED MAKES NO WARRANTY OF ANY KIND, EXPRESS OR IMPLIED, WITH REGARDS TO THIS DOCUMENT, INCLUDING, BUT NOT LIMITED TO, THE IMPLIED WARRANTIES OF MERCHANTABILITY AND FITNESS FOR A PARTICULAR PURPOSE (AND THEIR EQUIVALENTS UNDER THE LAWS OF ANY JURISDICTION).

Diodes Incorporated and its subsidiaries reserve the right to make modifications, enhancements, improvements, corrections or other changes without further notice to this document and any product described herein. Diodes Incorporated does not assume any liability arising out of the application or use of this document or any product described herein; neither does Diodes Incorporated convey any license under its patent or trademark rights, nor the rights of others. Any Customer or user of this document or products described herein in such applications shall assume all risks of such use and will agree to hold Diodes Incorporated and all the companies whose products are represented on Diodes Incorporated website, harmless against all damages.

Diodes Incorporated does not warrant or accept any liability whatsoever in respect of any products purchased through unauthorized sales channel. Should Customers purchase or use Diodes Incorporated products for any unintended or unauthorized application, Customers shall indemnify and hold Diodes Incorporated and its representatives harmless against all claims, damages, expenses, and attorney fees arising out of, directly or indirectly, any claim of personal injury or death associated with such unintended or unauthorized application.

Products described herein may be covered by one or more United States, international or foreign patents pending. Product names and markings noted herein may also be covered by one or more United States, international or foreign trademarks.

This document is written in English but may be translated into multiple languages for reference. Only the English version of this document is the final and determinative format released by Diodes Incorporated.

LIFE SUPPORT

Diodes Incorporated products are specifically not authorized for use as critical components in life support devices or systems without the express written approval of the Chief Executive Officer of Diodes Incorporated. As used herein:

A. Life support devices or systems are devices or systems which:

1. are intended to implant into the body, or
2. support or sustain life and whose failure to perform when properly used in accordance with instructions for use provided in the labeling can be reasonably expected to result in significant injury to the user.

B. A critical component is any component in a life support device or system whose failure to perform can be reasonably expected to cause the failure of the life support device or to affect its safety or effectiveness.

Customers represent that they have all necessary expertise in the safety and regulatory ramifications of their life support devices or systems, and acknowledge and agree that they are solely responsible for all legal, regulatory and safety-related requirements concerning their products and any use of Diodes Incorporated products in such safety-critical, life support devices or systems, notwithstanding any devices- or systems-related information or support that may be provided by Diodes Incorporated. Further, Customers must fully indemnify Diodes Incorporated and its representatives against any damages arising out of the use of Diodes Incorporated products in such safety-critical, life support devices or systems.

Copyright © 2012, Diodes Incorporated

www.diodes.com