

### 1. General Description

The DM9161 is a physical layer, single-chip, and low power transceiver for 100BASE-TX 100BASE-FX and 10BASE-T operations. On the media side, it provides a direct interface either to Unshielded Twisted Pair Category 5 Cable (UTP5) for 100BASE-TX Fast Ethernet, or UTP5/UTP3 Cable for 10BASE-T Ethernet. Through the Media Independent Interface (MII), the DM9161 connects to the Medium Access Control (MAC) layer, ensuring a high inter-operability from different vendors.

The DM9161 uses a low power and high performance CMOS process. It contains the entire physical layer

functions of 100BASE-TX as defined by IEEE802.3u, including the Physical Coding Sublayer (PCS), Physical Medium Attachment (PMA), Twisted Pair Physical Medium Dependent Sublayer (TP-PMD), 10BASE-TX Encoder/Decoder (ENC/DEC), and Twisted Pair Media Access Unit (TPMAU). The DM9161 provides a strong support for the auto-negotiation function, utilizing automatic media speed and protocol selection. Furthermore, due to the built-in wave-shaping filter, the DM9161 needs no external filter to transport signals to the media in 100BASE-TX or 10BASE-T Ethernet operation.

### 2. Block Diagram

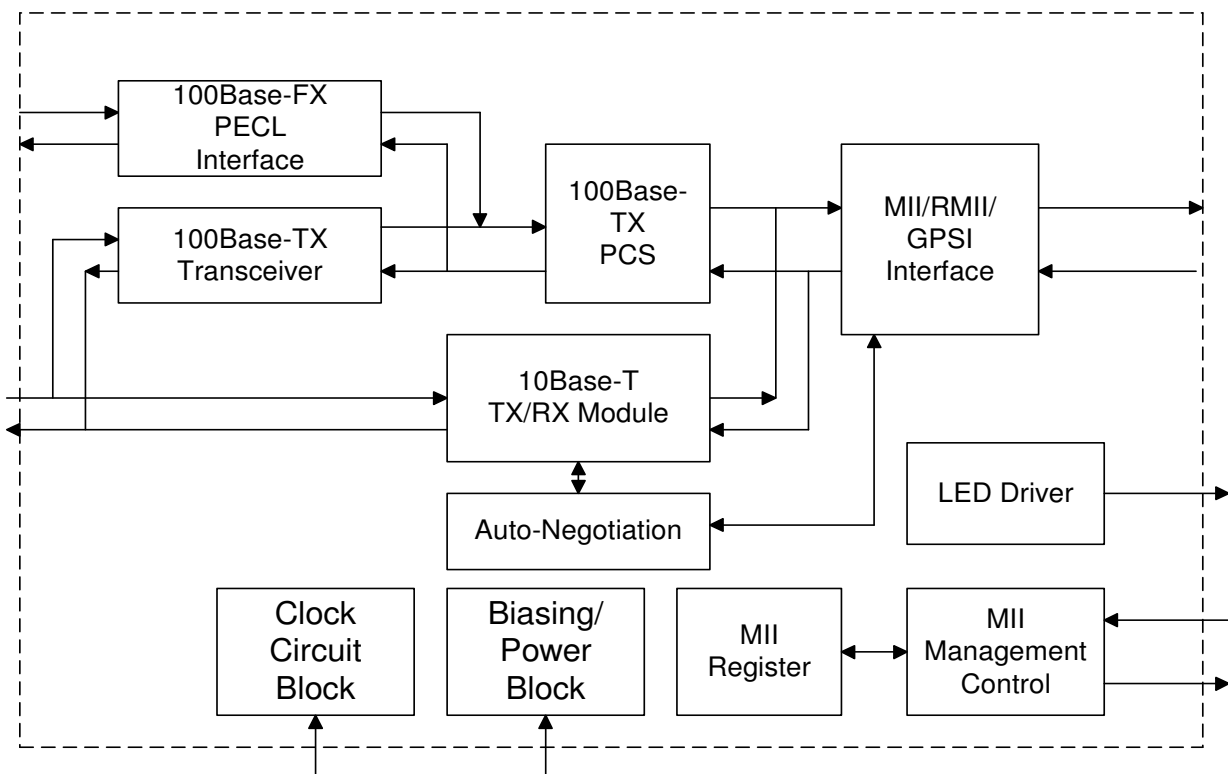



## Table of Contents

1. General Description .....	3	7.2.10 Management Interface – Write Frame Structure .....	19
2. Block Diagram .....	3	7.2.11 Power Reduced Mode .....	20
3. Features .....	4	7.2.12 Power Down Mode.....	20
4. Pin Configuration: DM9161 LQFP .....	5	7.2.13 Reduced Transmit Power Mode .....	20
5. Pin Description .....	6	8. MII Register Description.....	21
5.1 Normal MII Interface, 21 pins .....	6	8.1 Basic Mode Control Register (BMCR) - 00 .....	22
5.2 Media Interface, 4 pins.....	8	8.2 Basic Mode Status Register (BMSR) - 01.....	23
5.3 LED Interface, 3 pins .....	8	8.3 PHY ID Identifier Register #1 (PHYIDR1) - 02.....	24
5.4 Mode, 2 pins.....	8	8.4 PHY ID Identifier Register #2 (PHYIDR2) - 03.....	24
5.5 Bias and Clock, 4 pins .....	9	8.5 Auto-negotiation Advertisement Register (ANAR) - 04 .....	25
5.6 Power, 13 pins.....	9	8.6 Auto-negotiation Link Partner Ability Register (ANLPAR) - 05 .....	26
5.7 Table A.....	9	8.7 Auto-negotiation Expansion Register (ANER) - 06 .....	27
5.8 Pin Maps of Normal MII, Reduced MII, and 10Base-T GPSI (7-Wired) Mode .....	10	8.8 DAVICOM Specified Configuration Register (DSCR) –16 .....	27
6. LED Configuration .....	11	8.9 DAVICOM Specified Configuration and Status Register (DSCSR) - 17.....	29
7. Functional Description .....	12	8.10 10Base-T Configuration / Status (10BTC SR) - 18 .....	30
7.1 MII interface.....	12	8.11 DAVICOM Specified Interrupt Register - 21... ..	30
7.2 100Base-TX Operation .....	14	8.12 DAVICOM Specified Receive Error Counter Register (RECR) - 22 .....	31
7.2.1 100Base-TX Transmit .....	14	8.13 DAVICOM Specified Disconnect Counter Register (DISCR) - 23 .....	31
7.2.1.1 4B5B Encoder.....	15	8.14 DAVICOM Hardware Reset Latch State Register (RLSR) - 24 .....	31
7.2.1.2 Scrambler .....	15	9. DC and AC Electrical Characteristics	
7.2.1.3 Parallel to Serial Converter .....	15	9.1 Absolute Maximum Ratings( 25°C).....	32
7.2.1.4 NRZ to NRZI Encoder .....	15	9.2 Operating Conditions .....	32
7.2.1.5 MLT-3 Converter.....	15	9.3 DC Electrical Characteristics.....	33
7.2.1.6 MLT-3 Driver.....	15	9.4 AC Electrical Characteristics & Timing Waveform.....	33
7.2.1.7 4B5B Code Group.....	16	9.4.1 TP Interface .....	33
7.2.2 100Base-TX Receiver.....	17	9.4.2 Oscillator/Crystal Timing .....	33
7.2.2.1 Signal Detect .....	17	9.4.3 MDC/MDIO Timing .....	34
7.2.2.2 Adaptive Equalizer .....	17	9.4.4 MDIO Timing when OUTPUT by STA .....	34
7.2.2.3 MLT-3 to NRZI Decoder .....	17	9.4.5 MDIO Timing when OUTPUT by DM9161 ....	34
7.2.2.4 Clock Recovery Module .....	18	9.4.6 100Base-TX Transmit Timing Parameters....	35
7.2.2.5 NRZI to NRZ.....	18	9.4.7 100Base-TX Transmit Timing Diagram.....	35
7.2.2.6 Serial to Parallel.....	18	9.4.8 100Base-TX Receive Timing Parameters.....	35
7.2.2.7 Descrambler .....	18	9.4.9 MII 100Base-TX Receive Timing Diagram....	36
7.2.2.8 Code Group Alignment.....	18	9.4.10 MII 10Base-T Nibble Transmit Timing Parameters.....	36
7.2.2.9 4B5B Decoder .....	18		
7.2.3 10Base-T Operation.....	18		
7.2.4 Collision Detection .....	18		
7.2.5 Carrier Sense .....	18		
7.2.6 Auto-Negotiation .....	18		
7.2.7 MII Serial Management .....	19		
7.2.8 Serial Management Interface .....	19		
7.2.9 Management Interface – Read Frame Structure.....	19		



9.4.11 MII 10Base-T Nibble Transmit Timing Diagram .....	36	10. Application Notes .....	40
9.4.12 MII 10Base-T Receive Nibble Timing Parameters .....	37	10.1 Network Interface Signal Routing .....	40
9.4.13 MII 10Base-T Receive Nibble Timing Diagram .....	37	10.2 10Base-T/100Base-TX Application.....	40
9.4.14 Auto-negotiation and Fast Link Pulse Timing Parameters.....	37	10.3 10Base-T (Power Reduction Application) .....	41
9.4.15 Auto-negotiation and Fast Link Pulse Timing Diagram.....	38	10.4 Power Decoupling Capacitors .....	42
9.4.16 RMII Receive Timing Diagram .....	38	10.5 Ground Plane Layout .....	43
9.4.17 RMII Transmit Timing Diagram .....	38	10.6 Power Plane Partitioning.....	44
9.4.18 RMII Timing Diagram .....	39	10.7 Magnetics Selection Guide.....	45
9.4.19 RMII Timing Parameter .....	39	10.8 Crystal Selection Guide.....	45
		11. Package Information .....	46
		12. Order Information.....	47

### 3. Features

- Fully complies with IEEE 802.3u 10Base-T/100Base-TX/FX
- Support Auto-Negotiation function, compliant with IEEE 802.3u
- Fully integrated Physical layer single chip with direct interface to magnetic
- Integrated 10Base-T and 100Base-TX transceiver
- Selectable repeater or node mode
- Far end fault signaling option in FX mode
- Selectable MII or RMI (Reduced MII) interface, at the 100BASE-TX
- Selectable GPSI (7-Wired) or MII mode at the 10Base-T.
- Selectable twisted-pair or fiber mode output
- Selectable full-duplex or half-duplex operation
- MII management interface with maskable interrupt output capability
- Provide Loopback mode for easy system diagnostics
- LED status outputs indicate Link/ Activity, Speed10/100 and Full-duplex/Collision.
- Single low power Supply of 3.3V with 0.35 $\mu$ m CMOS technology
- Very Low Power consumption modes:
  - Power Reduced mode (cable detection)
  - Power Down mode
  - Selectable TX drivers for 1:1 or 1.25:1 transformers for additional power reduction.
- Compatible with 3.3V and 5.0V tolerant I/Os
- 48-pin LQFP small package (1x1 cm)

## 4. Pin Configuration: DM9161 LQFP

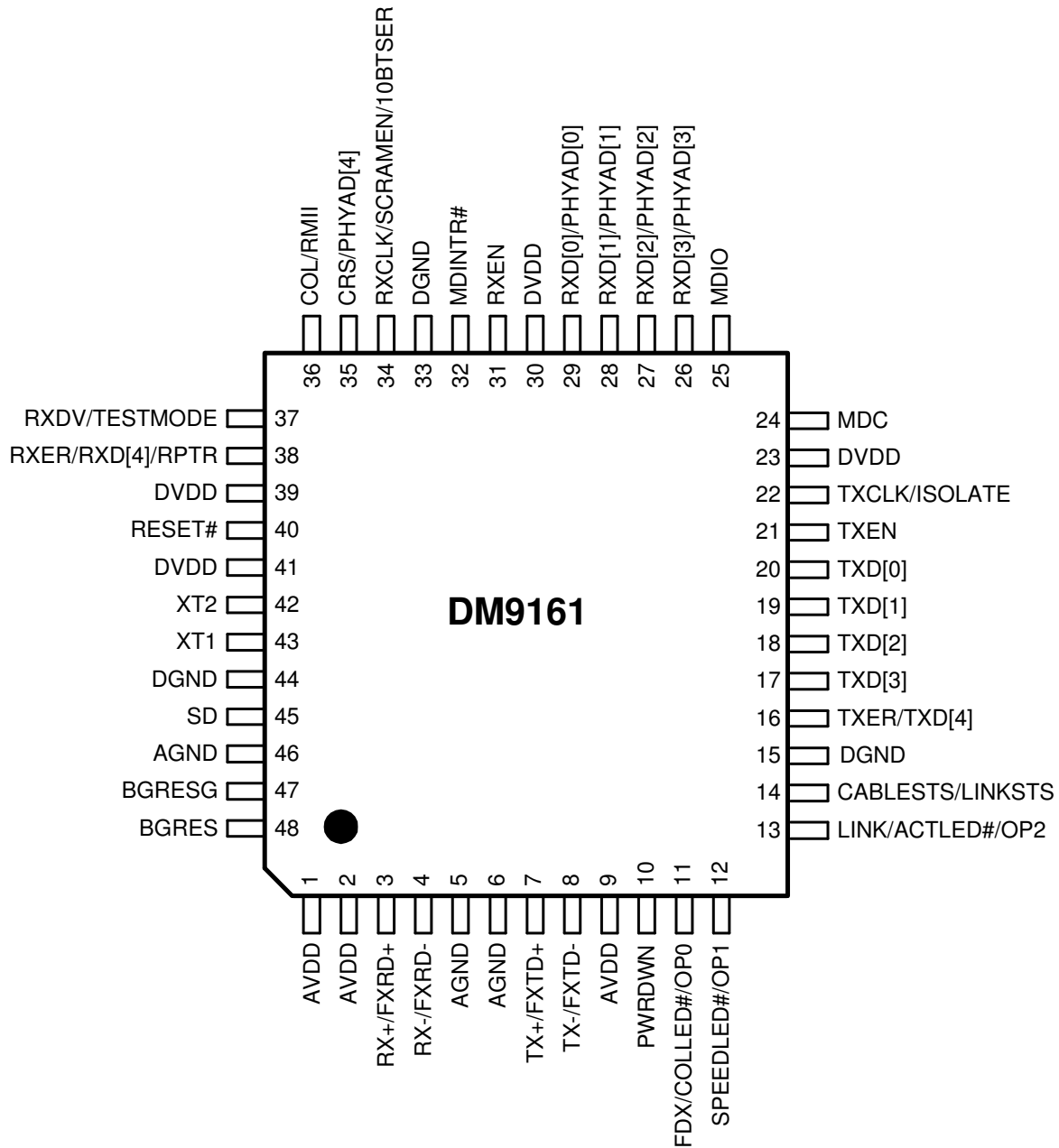

## 5. Pin Description

I: Input, O: Output, LI: Latch input when power-up/reset, Z: Tri-State output, U: Pulled up  
D: Pulled down

### 5.1 Normal MII Interface, 21 pins

Pin No.	Pin Name	I/O	Description
16	TXER/TXD [4]	I	Transmit Error/The Fifth TXD Data Bit In 100Mbps mode, when the signal indicates active high and TXEN is active, the HALT symbol substitutes the actual data nibble. In 10Mbps, the input is ignored In bypass mode (bypass BP4B5B), TXER becomes the TXD [4] pin, the fifth TXD data bit of the 5B symbol
20,19,18,17	TXD [0:3]	I	Transmit Data 4-bit nibble data inputs (synchronous to the TXCLK) when in 10/100Mbps nibble mode. In 10Mbps GPSI (7-Wired) mode, the TXD [0] pin is used as the serial data input pin, and TXD [1:3] are ignored.
21	TXEN	I	Transmit Enable Active high indicates the presence of valid nibble data on the TXD [0:3] for both 100Mbps and 10Mbps nibble modes. In 10Mbps GPSI (7-Wired) mode, active high indicates the presence of valid 10Mbps data on TXD [0].
22	TXCLK/ ISOLATE	O, Z, LI (D)	Transmit Clock The transmitting clock provides the timing reference for the transfer of the TXEN, TXD, and TXER. TXCLK is provided by the PHY 25MHz in 100Mbps nibble mode, 2.5MHz in 10Mbps nibble mode, 10MHz in 10Mbps GPSI (7-Wired) mode ISOLATE Setting: 0: Reg 0.10 will be initialized to "0".(Ref. to 8.1 Basic Control Register) 1: Reg 0.10 will be initialized to "1".
24	MDC	I	Management Data Clock Synchronous clock for the MDIO management data. This clock is provided by management entity, and it is up to 2.5MHz
25	MDIO	I/O	Management Data I/O Bi-directional management data which may be provided by the station management entity or the PHY
29,28,27,26	RXD[0:3] /PHYAD[0:3]	O, Z, LI (D)	Receive Data Output 4-bit nibble data outputs (synchronous to RXCLK) when in 10/100Mbps MII mode In 10Mbps GPSI (7-Wired) mode, the RXD [0] pin is used as the serial data output pin, and the RXD [1:3] are ignored PHY address [0:3] (power up reset latch input) PHY address sensing input pins
32	MDINTR#	O, Z	Status Interrupt Output: Asserted low whenever there is a status change (link, speed, duplex) The MDINTR# pin has a high impedance output, a 2.2K $\Omega$ pulled high resistor is needed



# DM9161

## 10/100 Mbps Fast Ethernet Physical Layer TX/FX Single Chip Transceiver

34	RXCLK /SCRAMEN /10BTSER	O, Z, LI (U)	Receive Clock The received clock provides the timing reference for the transfer of the RXDV, RXD, and RXER. RXCLK is provided by PHY. The PHY may recover the RXCLK reference from the received data or it may derive the RXCLK reference from a nominal clock 25MHz in 100Mbps MII mode, 2.5MHz in 10Mbps MII mode, 10MHz in 10Mbps GPSI (7-Wired) mode SCRAMEN 10BTSER only support for forced 100M mode or 10M mode; not support for auto-negotiation mode (power up reset latch input) 0 = Bypass scramble in 100M mode, GPSI (7-Wired) mode in 10M mode 1 = Enable scramble (default) in 100M mode, MII mode in 10M mode
35	CRS /PHYAD[4]	O, Z, LI (D)	Carrier Sense Detect/ PHYAD[4] Asserted high to indicate the presence of carrier due to receive or transmit activities in half-duplex mode of 10BASE-T or 100BASE-TX. In repeater mode or full-duplex mode, this signal is asserted high to indicate the presence of carrier due to receive activity only This pin is also used as PHYAD [4] (power up reset latch input) PHY address sensing input pin
36	COL /RMII	O, Z, LI (D)	Collision Detection Asserted high to indicate the detection of the collision conditions in 10Mbps and 100Mbps half-duplex mode. In full-duplex mode, this signal is always logical 0. Reduced MII enable: This pin is also used to select Normal MII or Reduced MII. (power up reset latch input) 0= Normal MII (default) 1= Reduced MII This pin is always pulled low except used as reduced MII
37	RXDV /TESTMODE	O, Z, LI (D)	Receive Data Valid Asserted high to indicate that the valid data is presented on the RXD [0:3] Test mode control pin (power up reset latch input) 0 = normal operation (default) 1 = enable test mode
38	RXER/RXD[4] /RPTR	O, Z, LI (D)	Receive Data Error/The Fifth RXD Data Bit of the 5B Symbol Asserted high to indicate that an invalid symbol has been detected In decoder bypass mode (bypass BP4B5B), RXER becomes RXD [4], the fifth RXD data bit of the 5B symbol This pin is also used to select Repeater or Node mode. (power up reset latch input) 0 = Node Mode (default) 1 = Repeater Mode
31	RXEN	I	Receive Enable Active high enables receive signals RXD [0:3], RXCLK, RXDV and RXCLK. Active low on this input tri-states these output pins. In node application, this pin should be pulled high. In repeater application, this pin may be connected to a repeater controller
40	RESET#	I	Reset Active low input that initializes the DM9161.

**5.2 Media Interface, 5 pins**

Pin No.	Pin Name	I/O	Description
3,4	RX+/FXRD+ RX-/FXRD-	I	Differential receive pair. Differential data is received from the media. Differential Pseudo ECL signal is received from the media in fiber mode.
7,8	TX+/FXTD+ TX-/FXTD-	O	Differential transmit pair. Differential data is transmitted to the media in TP mode. Differential Pseudo ECL signal transmits to the media in fiber mode.
45	SD	I	Fiber-optic signal detect PECL signal which indicates whether or not the fiber-optic receive pair is receiving valid signal levels.

**5.3 LED Interface, 3 pins**

Pin No.	Pin Name	I/O	Description
11	FDX /COL LED# /OP0	O, LI (U)	Full/Half Duplex LED Active states indicate the full-duplex mode. Active states see LED configuration Full-Duplex/Collision LED: when bit 5 of register 16 is set high Active states indicate the full-duplex mode or activity Collision LED when in the half-duplex mode. Active states see LED configuration OP0: (power up reset latch input) This pin is used to control the forced or advertised operating mode of the DM9161 according to the Table A. The value is latched into the DM9161 registers at power-up/reset
12	SPEED LED# /OP1	O, LI (U)	Speed LED Active states indicate the 100Mbps mode. Active states see LED configuration When bit 6 of Register 16 is set high, it controls the SPEED LED as 100Base-TX SD signal output. For debug only OP1: (power up reset latch input) This pin is used to control the forced or advertised operating mode of the DM9161 according to the Table A. The value is latched into the DM9161 registers at power-up/reset
13	LINK /ACT LED# /OP2	O, LI (U)	Link LED & Activity LED: Active states indicate the good link for 10Mbps and 100Mbps operations. It is also an active LED function when transmitting or receiving data. Active states see LED configuration OP2: (power up reset latch input) This pin is used to control the forced or advertised operating mode of the DM9161 according to the Table A. The value is latched into the DM9161 registers at power-up/reset

**5.4 Mode, 2 pins**

Pin No.	Pin Name	I/O	Description
10	PWRDWN	I	Power Down Control Asserted high to force the DM9161 into power down mode. When in power down mode, most of the DM9161 circuit block's power is turned off, only the MII management interface (MDC, MDIO) logic is available (the PHY should respond to management transactions and should not generate spurious signals on the MII). To leave power down mode, the DM9161 needs the hardware or software reset with the PWRDWN pin low
14	CABLESTS /LINKSTS	O, LI (D)	Cable Status or Link Status This pin is used to indicate the status of the cable connection when power up reset latch low (Default) 0 = Without cable connection 1 = With cable connection This pin is used to indicate the status of the Link connection when power up reset latch high 0 = Without link 1 = With link

**5.5 Bias and Clock, 4 pins**

Pin No.	Pin Name	I/O	Description
47	BGRESG	P	Bandgap Ground
48	BGRES	O	Bandgap Voltage Reference Resistor 6.8K ohm
42	XT2	I/O	Crystal Output; REF_CLK input for RMII mode
43	XT1	I	Crystal Input

**5.6 Power, 13 pins**

Pin No.	Pin Name	I/O	Description
1,2	AVDD	P	Analog Receive Power
9	AVDD	P	Analog Transmit Power
5	AGND	P	Analog Receive Ground
6	AGND	P	Analog Transmit Ground
46	AGND	P	Analog Substrate Ground
23,30,39,41	DVDD	P	Digital Power
15,33,44	DGND	P	Digital Ground

**5.7 Table A (Media Type Selection)**

OP2	OP1	OP0	Function
0	0	0	Dual Speed 100/10 HDX
0	0	1	Manually Select 100FX HDX
0	1	0	Manually Select 100FX FDX
0	1	1	Manually Select 10TX HDX
1	0	0	Manually Select 10TX FDX
1	0	1	Manually Select 100TX HDX
1	1	0	Manually Select 100TX FDX
1	1	1	Auto-negotiation Enables All Capabilities



**5.8 Pin Maps of Normal MII, Reduced MII, and 10Base-T GPSI (7-Wired) Mode**

<b>Normal MII Mode</b>	<b>Reduced MII Mode</b>	<b>10Base-T GPSI (7-Wired) Mode</b>
TXD [0:1]	TXD [0:1]	TXD [0] ; TXD [1] = NC
TXD [2:3]	NC	NC
TXEN	TXEN	TXEN
TXER/TXD [4]	NC	NC
TXCLK	NC	TXCLK
RXD [0:1]	RXD [0:1]	RXD [0] ; RXD [1] = NC
RXD[2:3]	NC	NC
RXEN	VCC	VCC
RXER/RXD[4]/RPTR/NODE	RPTR/NODE	RPTR/NODE
RXDV	CRS DV	NC
RXCLK	NC	RXCLK
COL	NC	COL
CRS (PHYADR [2:4]) (BP4B5B)	NC	CRS
MDC	MDC	MDC
MDIO	MDIO	MDIO
RESET#	RESET#	RESET#
XT1 (25 MHz)	XT1 (Floating)	XT1 (25 MHz)
XT2 (25 MHz)	XT2 (REF_CLK 50MHz)	XT2 (25 MHz)

## 6. LED Configuration

LEDs flash once per 200ms after power-on reset or software reset by writing PHY register. All LED pins are dual function pins, which can be configured as either active high or low by pulling them low or high

accordingly. If the pin is pulled high, the LED is active low after reset. Likewise, if the pin is pulled low, the LED is active high.

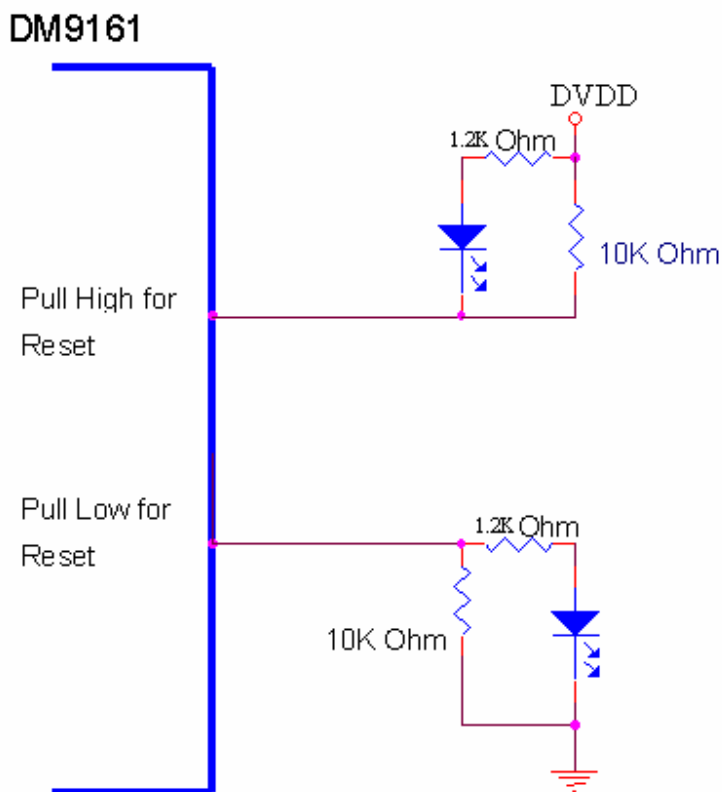

### 7. Functional Description

The DM9161 Fast Ethernet single-chip transceiver, providing the functionality as specified in IEEE 802.3u, integrates a complete 100Base-TX module and a complete 10Base-T module. The DM9161 provides a Media Independent Interface (MII) as defined in the IEEE 802.3u standard (Clause 22).

The DM9161 performs all PCS (Physical Coding Sublayer), PMA (Physical Media Access), TP-PMD (Twisted Pair Physical Medium Dependent) sublayer, 10Base-T Encoder/Decoder, and Twisted Pair Media Access Unit (TPMAU) functions. Figure 1 shows the major functional blocks implemented in the DM9161.

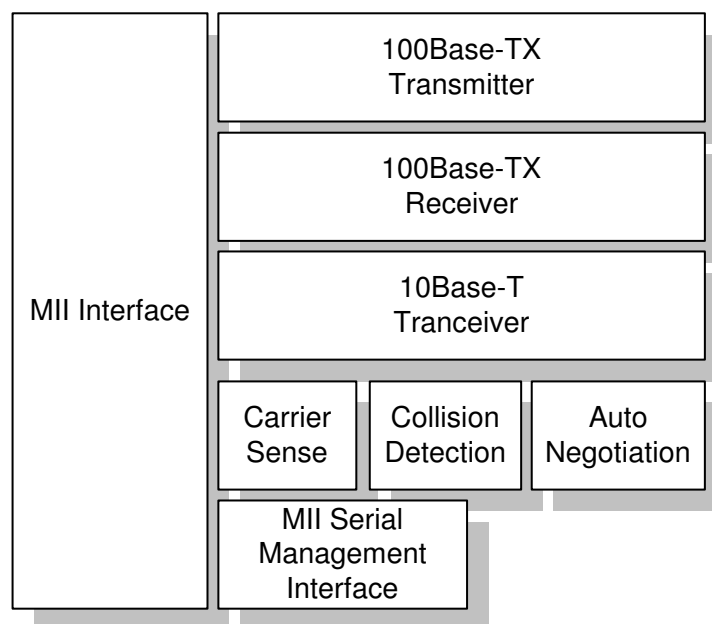

Figure 7-1

#### 7.1 MII Interface

The DM 9161 provides a Media Independent Interface (MII) as defined in the IEEE 802.3u standard (Clause 22).

The purpose of the MII interface is to provide a simple, easy to implement connection between the MAC Reconciliation layer and the PHY. The MII is designed to make the differences between various media transparent to the MAC sublayer.

The MII consists of a nibble wide receive data bus, a nibble wide transmit data bus, and control signals to facilitate data transfers between the PHY and the Reconciliation layer.

- TXD (transmit data) is a nibble (4 bits) of data that are driven by the reconciliation sublayer synchronously with

respect to TXCLK. For each TXCLK period, which TXEN is asserted, TXD(3:0) are accepted for transmission by the PHY.

- TXCLK (transmit clock) output to the MAC reconciliation sublayer is a continuous clock that provides the timing reference for the transfer of the TXEN, TXD, and TXER signals.
- TXEN (transmit enable) input from the MAC reconciliation sublayer indicates that nibbles are being presented on the MII for transmission on the physical medium.

### MII Interface (continued)

- TXER (transmit coding error) transitions are synchronously with respect to TXCLK. If TXER is asserted for one or more clock periods, and TXEN is asserted, the PHY will emit one or more symbols that are not part of the valid data delimiter set somewhere in the frame being transmitted.
- RXD (receive data) is a nibble (4 bits) of data that are sampled by the reconciliation sublayer synchronously with respect to RXCLK. For each RXCLK period which RXDV is asserted, RXD (3:0) are transferred from the PHY to the MAC reconciliation sublayer.
- RXCLK (receive clock) output to the MAC reconciliation sublayer is a continuous clock that provides the timing reference for the transfer of the RXDV, RXD, and RXER signals.
- RXDV (receive data valid) input from the PHY indicates that the PHY is presenting recovered and decoded nibbles to the MAC reconciliation sublayer. To interpret a receive frame correctly by the reconciliation sublayer, RXDV must encompass the frame, starting no later than the Start-of-Frame delimiter and excluding any End-Stream delimiter.
- RXER (receive error) transitions are synchronously with respect to RXCLK. RXER will be asserted for one or more clock periods to indicate to the reconciliation sublayer that an error was detected somewhere in the frame being transmitted from the PHY to the reconciliation sublayer.
- CRS (carrier sense) is asserted by the PHY when either the transmit or receive medium is non-idle, and de-asserted by the PHY when the transmit and receive medium are idle. Figure 7-2 depicts the behavior of CRS during 10Base-T and 100Base-TX transmission.

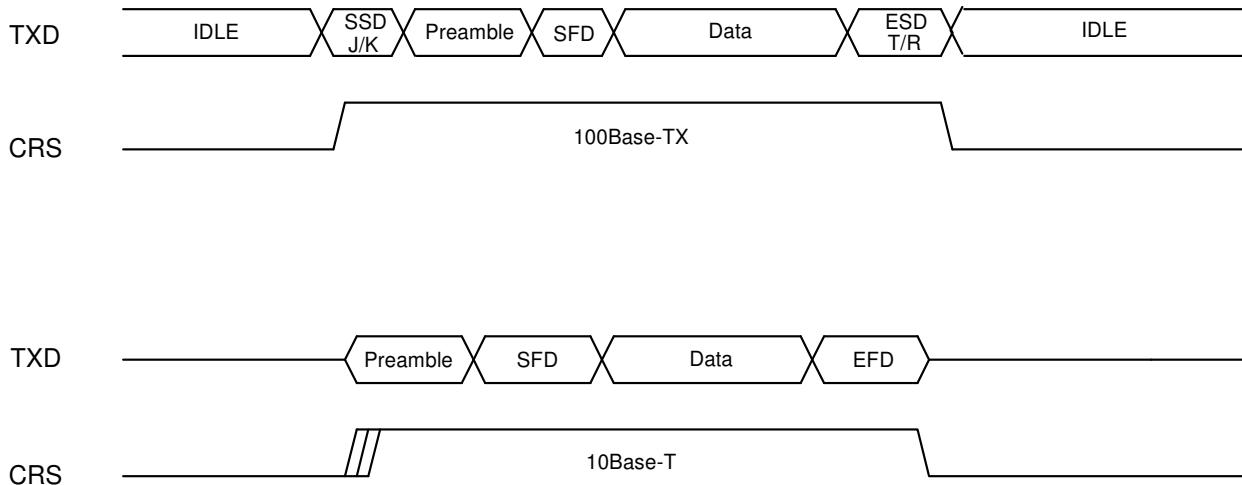

Figure 7-2

### 7.2 100Base-TX Operation

The 100Base-TX transmitter receives 4-bit nibble data clocked in at 25MHz at the MII, and outputs a scrambled 5-bit encoded MLT-3 signal to the media at 100Mbps. The on-chip clock circuit converts the 25MHz clock into a 125MHz clock for internal use.

The IEEE 802.3u specification defines the Media Independent Interface. The interface specification defines a dedicated receive data bus and a dedicated transmit data bus.

These two busses include various controls and signal indications that facilitate data transfers between the DM9161 and the Reconciliation layer.

#### 7.2.1 100Base-TX Transmit

The 100Base-TX transmitter consists of the functional blocks shown in figure 7-3. The 100Base-TX transmit section converts 4-bit synchronous data provided by the MII to a scrambled MLT-3 125, a million symbols per second serial data stream.

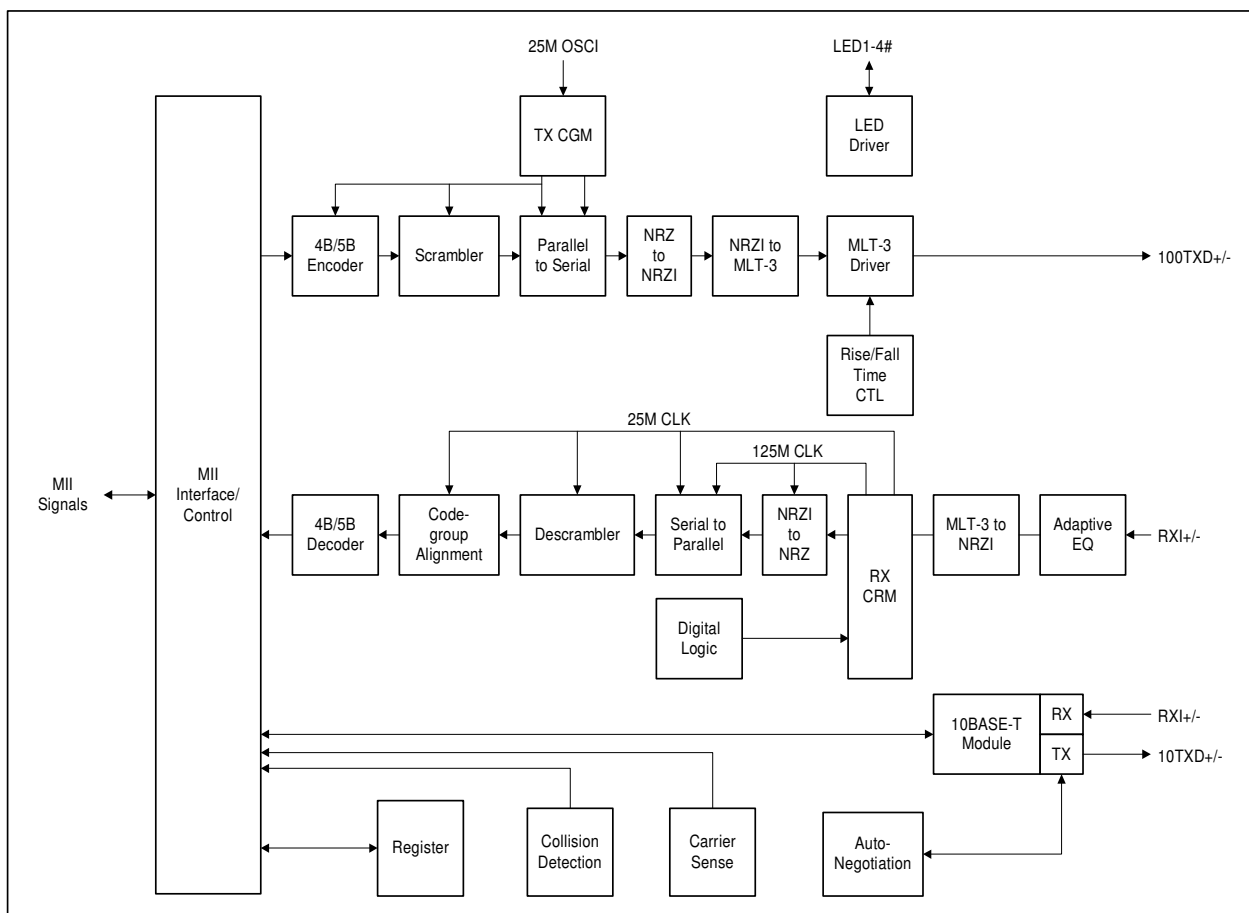

Figure 7-3

The block diagram in figure 7-3 provides an overview of the functional blocks contained in the transmit section.

The transmitter section contains the following functional blocks:

- 4B5B Encoder
- Scrambler
- Parallel to Serial Converter
- NRZ to NRZI Encoder
- NRZI to MLT-3
- MLT-3 Driver

#### **7.2.1.1 4B5B Encoder**

The 4B5B encoder converts 4-bit (4B) nibble data generated by the MAC Reconciliation Layer into a 5-bit (5B) code group for transmission, see reference Table 7-1. This conversion is required for control and packet data to be combined in code groups. The 4B5B encoder substitutes the first 8 bits of the MAC preamble with a J/K code group pair (11000 10001) upon transmit. The 4B5B encoder continues to replace subsequent 4B preamble and data nibbles with corresponding 5B code-groups. At the end of the transmit packet, upon the deassertion of the Transmit Enable signal from the MAC Reconciliation layer, the 4B5B encoder injects the T/R code group pair (01101 00111) indicating end of frame. After the T/R code group pair, the 4B5B encoder continuously injects IDLEs into the transmit data stream until Transmit Enable is asserted and the next transmit packet is detected.

The DM9161 includes a Bypass 4B5B conversion option within the 100Base-TX Transmitter for support of applications like 100 Mbps repeaters, which do not require 4B5B conversion.

#### **7.2.1.2 Scrambler**

The scrambler is required to control the radiated emissions (EMI) by spreading the transmit energy across the frequency spectrum at the media connector and on the twisted pair cable in 100Base-TX operation.

By scrambling the data, the total energy presented to the cable is randomly distributed over a wide frequency range. Without the scrambler, energy levels on the cable could peak beyond FCC limitations at frequencies related to repeated 5B sequences like continuous transmission of IDLE symbols. The scrambler output is combined with the NRZ 5B data from the code group encoder via an XOR logic function. The result is a scrambled data stream with sufficient randomization to decrease radiated emissions at critical frequencies.

#### **7.2.1.3 Parallel to Serial Converter**

The Parallel to Serial Converter receives parallel 5B scrambled data from the scrambler and serializes it (converts it from a parallel to a serial data stream). The serialized data stream is then presented to the NRZ to NRZI encoder block

#### **7.2.1.4 NRZ to NRZI Encoder**

Since the transmit data stream has been scrambled and serialized, the data must be NRZI encoded for compatibility with the TP-PMD standard for 100Base-TX transmission over Category-5 unshielded twisted pair cable.

#### **7.2.1.5 MLT-3 Converter**

The MLT-3 conversion is accomplished by converting the data stream output from the NRZI encoder into two binary data streams with alternately phased logic one events.

#### **7.2.1.6 MLT-3 Driver**

The two binary data streams, created at the MLT-3 converter, are fed to the twisted pair output driver, which converts these streams to current sources and alternately drives either side of the transmit transformer's primary winding, resulting in a minimal current MLT-3 signal. Refer to figure 7-4 for the block diagram of the MLT-3 converter.

**7.2.1.7 4B5B Code Group**

Symbol	Meaning	4B code 3210	5B Code 43210
0	Data 0	0000	11110
1	Data 1	0001	01001
2	Data 2	0010	10100
3	Data 3	0011	10101
4	Data 4	0100	01010
5	Data 5	0101	01011
6	Data 6	0110	01110
7	Data 7	0111	01111
8	Data 8	1000	10010
9	Data 9	1001	10011
A	Data A	1010	10110
B	Data B	1011	10111
C	Data C	1100	11010
D	Data D	1101	11011
E	Data E	1110	11100
F	Data F	1111	11101
I	Idle	undefined	11111
J	SFD (1)	0101	11000
K	SFD (2)	0101	10001
T	ESD (1)	undefined	01101
R	ESD (2)	undefined	00111
H	Error	undefined	00100
V	Invalid	undefined	00000
V	Invalid	undefined	00001
V	Invalid	undefined	00010
V	Invalid	undefined	00011
V	Invalid	undefined	00101
V	Invalid	undefined	00110
V	Invalid	undefined	01000
V	Invalid	undefined	01100
V	Invalid	undefined	10000
V	Invalid	undefined	11001

**Table 7-1**

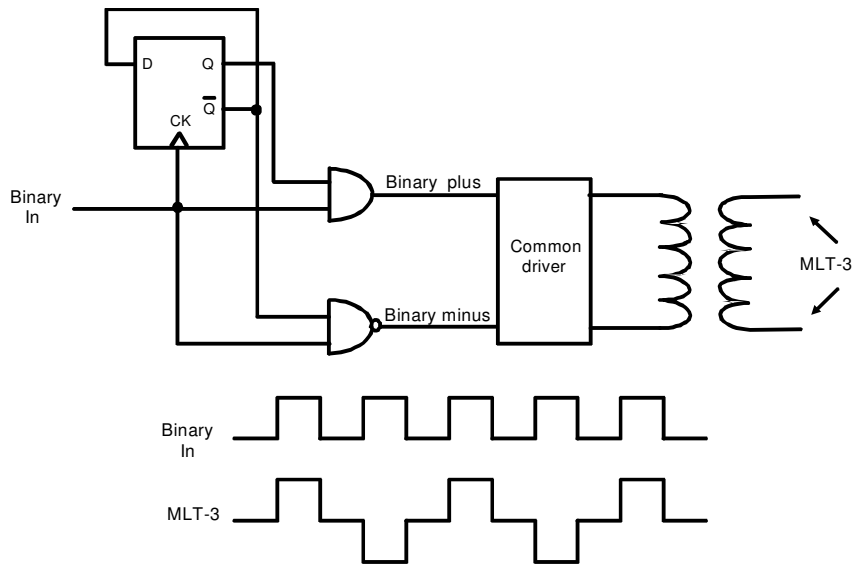
**Figure 7-4**

### 7.2.2 100Base-TX Receiver

The 100Base-TX receiver contains several function blocks that convert the scrambled 125Mb/s serial data to synchronous 4-bit nibble data, which is then provided to the MII.

The receive section contains the following functional blocks:

- Adaptive Equalizer
- MLT-3 to NRZI Decoder
- Clock Recovery Module
- NRZI to NRZ Decoder
- Serial to Parallel
- Descrambler
- Code Group Alignment
- 4B5B Decoder

#### 7.2.2.1 Signal Detect

The signal detect function meets the specifications mandated by the ANSI XT12 TP-PMD 100Base-TX Standards for both voltage thresholds and timing parameters.

#### 7.2.2.2 Adaptive Equalizer

When transmitting data at high speeds over copper twisted pair cable, attenuation based on frequency becomes a concern. In high speed twisted pair signaling, the frequency content of the transmitted signal can vary greatly during normal operation based on the randomness of the scrambled data stream. This variation in signal attenuation caused by frequency variations must be compensated for to ensure the integrity of the received data. In order to ensure quality transmission when employing MLT-3 encoding, the compensation must be able to adapt to various cable lengths and cable types depending on the installed environment. The selection of long cable lengths for a given implementation requires significant compensation, which will be over-kill in a situation that includes shorter, less attenuating cable lengths. Conversely, the selection of short or intermediate cable lengths requiring less compensation will cause serious under-compensation for longer length cables. Therefore, the compensation or equalization must be adaptive to ensure proper conditioning of the received signal independent of the cable length.

#### 7.2.2.3 MLT-3 to NRZI Decoder

The DM9161 decodes the MLT-3 information from the Digital Adaptive Equalizer into NRZI data. The relation between NRZI and MLT-3 data is shown in figure 7-4.

#### **7.2.2.4 Clock Recovery Module**

The Clock Recovery Module accepts NRZI data from the MLT-3 to NRZI decoder. The Clock Recovery Module locks onto the data stream and extracts the 125Mhz reference clock. The extracted and synchronized clock and data are presented to the NRZI to NRZ Decoder.

#### **7.2.2.5 NRZI to NRZ**

The transmit data stream is required to be NRZI encoded in for compatibility with the TP-PMD standard for 100Base-TX transmission over Category-5 unshielded twisted pair cable. This conversion process must be reversed on the receive end. The NRZI to NRZ decoder, receives the NRZI data stream from the Clock Recovery Module and converts it to a NRZ data stream to be presented to the Serial to Parallel conversion block.

#### **7.2.2.6 Serial to Parallel**

The Serial to Parallel Converter receives a serial data stream from the NRZI to NRZ converter, and converts the data stream to parallel data to be presented to the descrambler.

#### **7.2.2.7 Descrambler**

Because the scrambling process requires to control the radiated emissions of transmit data streams, the receiver must descramble the receive data streams. The descrambler receives scrambled parallel data streams from the Serial to Parallel converter, descrambles the data streams, and presents the data streams to the Code Group alignment block.

#### **7.2.2.8 Code Group Alignment**

The Code Group Alignment block receives un-aligned 5B data from the descrambler and converts it into 5B code group data. Code Group Alignment occurs after the J/K is detected, and subsequent data is aligned on a fixed boundary.

#### **7.2.2.9 4B5B Decoder**

The 4B5B Decoder functions as a look-up table that translates incoming 5B code groups into 4B (Nibble) data. When receiving a frame, the first 2 5-bit code groups received are

the start-of-frame delimiter (J/K symbols). The J/K symbol pair is stripped and two nibbles of preamble pattern are substituted. The last two code groups are the end-of-frame delimiter (T/R symbols).

The T/R symbol pair is also stripped from the nibble presented to the Reconciliation layer.

#### **7.2.3 10Base-T Operation**

The 10Base-T transceiver is IEEE 802.3u compliant. When the DM9161 is operating in 10Base-T mode, the coding scheme is Manchester. Data processed for transmit is presented to the MII interface in nibble format, converted to a serial bit stream, then Manchester encoded. When receiving, the Manchester encoded bit stream is decoded and converted into nibble format for presentation to the MII interface.

#### **7.2.4 Collision Detection**

For half-duplex operation, a collision is detected when the transmit and receive channels are active simultaneously. When a collision has been detected, it will be reported by the COL signal on the MII interface. Collision detection is disabled in Full Duplex operation.

#### **7.2.5 Carrier Sense**

Carrier Sense (CRS) is asserted in half-duplex operation during transmission or reception of data. During full-duplex mode, CRS is asserted only during receive operations.

#### **7.2.6 Auto-Negotiation**

The objective of Auto-negotiation is to provide a means to exchange information between segment linked devices and to automatically configure both devices to take maximum advantage of their abilities. It is important to note that Auto-negotiation does not test the link segment characteristics. The Auto-Negotiation function provides a means for a device to advertise supported modes of operation to a remote link partner, acknowledge the receipt and understanding of common modes of operation, and to reject un-shared modes of operation. This allows devices on both ends of a segment to establish a link at the best common mode of operation. If more than one common mode exists between the two devices, a mechanism is provided to allow the devices to resolve to a single mode of operation using a predetermined priority resolution function.

**Auto-Negotiation** (continued)

Auto-negotiation also provides a parallel detection function for devices that do not support the Auto-negotiation feature. During Parallel detection there is no exchange of configuration information, instead, the receive signal is examined. If it is discovered that the signal matches a technology, supported by the receiving device, a connection will be automatically established using that technology. This allows devices, which do not support Auto-negotiation but support a common mode of operation, to establish a link.

**7.2.7 MII Serial Management**

The MII serial management interface consists of a data interface, basic register set, and a serial management interface to the register set. Through this interface it is possible to control and configure multiple PHY devices, get status and error information, and determine the type and capabilities of the attached PHY device(s).

The DM9161 management functions correspond to MII specification for IEEE 802.3u-1995 (Clause 22) for registers 0 through 6 with vendor-specific registers 16,17, 18, 21, 22, 23 and 24.

In read/write operation, the management data frame is 64-bits long and starts with 32 contiguous logic one bits (preamble) synchronization clock cycles on MDC. The Start of Frame Delimiter (SFD) is indicated by a <01> pattern followed by the operation code (OP):<10> indicates Read operation and <01> indicates Write operation. For read operation, a 2-bit turnaround (TA) field between Register Address field and Data field is provided for MDIO to avoid contention. Following the turnaround time, 16-bit data is read from or written onto management registers.

**7.2.8 Serial Management Interface**

The serial control interface uses a simple two-wired serial interface to obtain and control the status of the physical layer through the MII interface. The serial control interface consists of MDC (Management Data Clock), and MDI/O (Management Data Input/Output) signals.

The MDIO pin is bi-directional and may be shared by up to 32 devices.

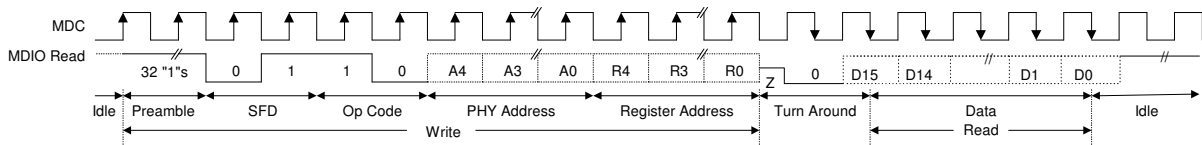
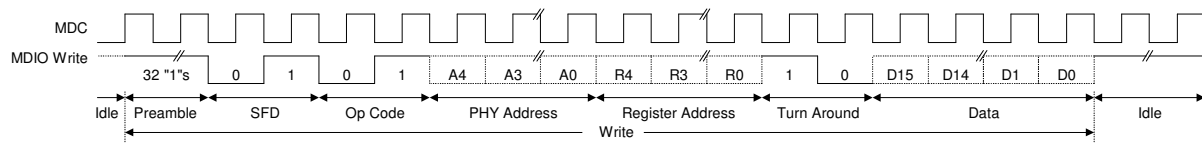
**7.2.9 Management Interface - Read Frame Structure**

**7.2.10 Management Interface - Write Frame Structure**

**Figure 7-5**



### 7.2.11 Power Reduced Mode

The Signal detect circuit is always turned on to monitor whether there is any signal on the media. In case of cable disconnection,, DM9161 will automatically turn off the power and enter the Power Reduced mode, regardless of its operation mode being N-way auto-negotiation or forced mode. While in the Power Reduced mode, the transmit circuit will continue sending out fast link pulses with minimum power consumption. If a valid signal is detected from the media, which might be N-way fast link pulses, 10Base-T normal link pulses, or 100Base-TX MLT3 signals, the device wakes up and resumes normal operation mode.

Automatic reduced power down mode can be disabled by writing Zero to Reg.16.4.

### 7.2.12 Power Down Mode

Power Down mode is entered by setting Reg.0.11 to ONE or pulling PWRDWN pin high, which disables all transmit and receive functions, and MII interface functions except the MDC/MDIO management interface.

### 7.2.13 Reduced Transmit Power Mode

Additional transmit power reduction can be gained by designing with 1.25:1 turns ratio magnetic on its TX side and using a 8.5K $\Omega$  resistor on BGRES and BGRESG pins, and the TX+/TX- pulled high resistors being changed from 50 $\Omega$  to 78 $\Omega$ . This configuration could reduce about 20% of transmit power.



**8. MII Register Description**

ADD	Name	15	14	13	12	11	10	9	8	7	6	5	4	3	2	1	0
00	CONTROL	Reset	Loop back	Speed select	Auto-N Enable	Power Down	Isolate	Restart Auto-N	Full Duplex	Coll. Test	Reserved						
01	STATUS	T4 Cap.	TX FDX Cap.	TX HDX Cap.	10 FDX Cap.	10 HDX Cap.	Reserved				Pream. Supr.	Auto-N Compl.	Remote Fault	Auto-N Cap.	Link Status	Jabber Detect	Extd Cap.
02	PHYID1	0	0	0	0	0	0	0	1	1	0	0	0	0	0	0	0
03	PHYID2	1	0	1	1	1	0	Model No.				Version No.					
04	Auto-Neg. Advertise	Next Page	FLP Rcv Ack	Remote Fault	Reserved		FC Adv	T4 Adv	TX FDX Adv	TX HDX Adv	10 FDX Adv	10 HDX Adv	Advertised Protocol Selector Field				
05	Link Part. Ability	LP Next Page	LP Ack	LP RF	Reserved		LP FC	LP T4	LP TX FDX	LP TX HDX	LP 10 FDX	LP 10 HDX	Link Partner Protocol Selector Field				
06	Auto-Neg. Expansion	Reserved										Pardet Fault	LP Next Pg Able	Next Pg Able	New Pg Rcv	LP AutoN Cap.	
16	Aux. Config.	BP 4B5B	BP SCR	BP ALIGN	BP_A DPOK	Repeat mode	TX/FX Select	FEF Enable	RMI Enable	Force 100LNK	SPDLE D_CTL	COLLE D_CTL	RPDCT R-EN	Reset St. Mch	Pream. Supr.	Sleep mode	Remote LoopOut
17	Aux. Conf/Stat	100 FDX	100 HDX	10 FDX	10 HDX	Reserved			PHY ADDR [4:0]				Auto-N. Monitor Bit [3:0]				
18	10T Conf/Stat	Rsvd	LP Enable	HBE Enable	SQUE Enable	JAB Enable	10T Serial	Reserved									Polarity Reverse
21	MDINTR	INTR PEND	Rsvd	Rsvd	Rsvd	FDX Mask	SPD Mask	Link Mask	INTR Mask	Rsvd	Rsvd	Rsvd	FDX Change	SPD Change	Link Change	Rsvd	INTR Status
22	Rcv Error Counter	Receive Error Counter															
23	Disconnect Counter	Reserved								Disconnect Counter							
24	Rstlh Stat	0	0	LH_ISO	LH_CSTS	LH_RMII	LH_SCRAM	LH_REP	LH_T5TMOD	LH_OP [2:0]			LH_PHYAD [4:0]				

**Key to Default**

In the register description that follows, the default column takes the form:  
 <Reset Value>, <Access Type> / <Attribute(s)>

<Access Type>:  
 RO = Read only  
 RW = Read/Write

Where :

<Reset Value>:

- 1 Bit set to logic one
- 0 Bit set to logic zero
- X No default value
- (PIN#) Value latched in from pin # at reset

<Attribute (s)>:

- SC = Self clearing
- P = Value permanently set
- LL = Latching low
- LH = Latching high

**8.1 Basic Mode Control Register (BMCR) - 00**

Bit	Bit Name	Default	Description
0.15	Reset	0, RW/SC	Reset 1=Software reset 0=Normal operation This bit sets the status and controls the PHY registers to their default states. This bit, which is self-clearing, will keep returning a value of one until the reset process is completed
0.14	Loopback	0, RW	Loopback Loop-back control register 1 = Loop-back enabled 0 = Normal operation When in 100Mbps operation mode, setting this bit may cause the descrambler to lose synchronization and produce a 720ms "dead time" before any valid data appears at the MII receive outputs
0.13	Speed selection	1, RW	Speed Select 1 = 100Mbps 0 = 10Mbps Link speed may be selected either by this bit or by auto-negotiation. When auto-negotiation is enabled and bit 12 is set, this bit will return auto-negotiation selected medium type
0.12	Auto-negotiation enable	1, RW	Auto-negotiation Enable 1 = Auto-negotiation is enabled, bit 8 and 13 will be in auto-negotiation status
0.11	Power down	0, RW	Power Down While in the power-down state, the PHY should respond to management transactions. During the transition to power-down state and while in the power-down state, the PHY should not generate spurious signals on the MII 1=Power down 0=Normal operation
0.10	Isolate	0,RW	Isolate 1 = Isolates the DM9161 from the MII with the exception of the serial management. (When this bit is asserted, the DM9161 does not respond to the TXD [0:3], TX_EN, and TX_ER inputs, and it shall present a high impedance on its TX_CLK, RX_CLK, RX_DV, RX_ER, RX [0:3], COL and CRS outputs. When PHY is isolated from the MII it shall respond to the management transactions) 0 = Normal operation
0.9	Restart Auto-negotiation	0,RW/SC	Restart Auto-negotiation 1 = Restart auto-negotiation. Re-initiates the auto-negotiation process. When auto-negotiation is disabled (bit 12 of this register cleared), this bit has no function and it should be cleared. This bit is self-clearing and it will keep returning to a value of 1 until auto-negotiation is initiated by the DM9161. The operation of the auto-negotiation process will not be affected by the management entity that clears this bit 0 = Normal operation

0.8	Duplex mode	1,RW	Duplex Mode 1 = Full duplex operation. Duplex selection is allowed when Auto-negotiation is disabled (bit 12 of this register is cleared). With auto-negotiation enabled, this bit reflects the duplex capability selected by auto-negotiation 0 = Normal operation
0.7	Collision test	0,RW	Collision Test 1 = Collision test enabled. When set, this bit will cause the COL signal to be asserted in response to the assertion of TX_EN 0 = Normal operation
0.6-0.0	Reserved	0,RO	Reserved Read as 0, ignore on write

**8.2 Basic Mode Status Register (BMSR) - 01**

Bit	Bit Name	Default	Description
1.15	100BASE-T4	0,RO/P	100BASE-T4 Capable 1 = DM9161 is able to perform in 100BASE-T4 mode 0 = DM9161 is not able to perform in 100BASE-T4 mode
1.14	100BASE-TX full-duplex	1,RO/P	100BASE-TX Full Duplex Capable 1 = DM9161 is able to perform 100BASE-TX in full duplex mode 0 = DM9161 is not able to perform 100BASE-TX in full duplex mode
1.13	100BASE-TX half-duplex	1,RO/P	100BASE-TX Half Duplex Capable 1 = DM9161 is able to perform 100BASE-TX in half duplex mode 0 = DM9161 is not able to perform 100BASE-TX in half duplex mode
1.12	10BASE-T full-duplex	1,RO/P	10BASE-T Full Duplex Capable 1 = DM9161 is able to perform 10BASE-T in full duplex mode 0 = DM9161 is not able to perform 10BASE-TX in full duplex mode
1.11	10BASE-T half-duplex	1,RO/P	10BASE-T Half Duplex Capable 1 = DM9161 is able to perform 10BASE-T in half duplex mode 0 = DM9161 is not able to perform 10BASE-T in half duplex mode
1.10-1.7	Reserved	0,RO	Reserved Read as 0, ignore on write
1.6	MF preamble suppression	0,RO	MII Frame Preamble Suppression 1 = PHY will accept management frames with preamble suppressed 0 = PHY will not accept management frames with preamble suppressed
1.5	Auto-negotiation Complete	0,RO	Auto-negotiation Complete 1 = Auto-negotiation process completed 0 = Auto-negotiation process not completed
1.4	Remote fault	0, RO/LH	Remote Fault 1 = Remote fault condition detected (cleared on read or by a chip reset). Fault criteria and detection method is DM9161 implementation specific. This bit will set after the RF bit in the ANLPAR (bit 13, register address 05) is set 0 = No remote fault condition detected
1.3	Auto-negotiation ability	1,RO/P	Auto Configuration Ability 1 = DM9161 is able to perform auto-negotiation 0 = DM9161 is not able to perform auto-negotiation



1.2	Link status	0,RO/LL	Link Status 1 = Valid link is established (for either 10Mbps or 100Mbps operation) 0 = Link is not established The link status bit is implemented with a latching function, so that the occurrence of a link failure condition causes the link status bit to be cleared and remain cleared until it is read via the management interface
1.1	Jabber detect	0, RO/LH	Jabber Detect 1 = Jabber condition detected 0 = No jabber This bit is implemented with a latching function. Jabber conditions will set this bit unless it is cleared by a read to this register through a management interface or a DM9161 reset. This bit works only in 10Mbps mode
1.0	Extended capability	1,RO/P	Extended Capability 1 = Extended register capable 0 = Basic register capable only

**8.3 PHY ID Identifier Register #1 (PHYID1) - 02**

The PHY Identifier Registers #1 and #2 work together in a single identifier of the DM9161. The Identifier consists of a concatenation of the Organizationally Unique Identifier (OUI), a vendor's model number, and a model revision number. DAVICOM Semiconductor's IEEE assigned OUI is 00606E.

Bit	Bit Name	Default	Description
2.15-2.0	OUI_MSB	<0181h>	OUI Most Significant Bits This register stores bit 3 to 18 of the OUI (00606E) to bit 15 to 0 of this register respectively. The most significant two bits of the OUI are ignored (the IEEE standard refers to these as bit 1 and 2)

**8.4 PHY ID Identifier Register #2 (PHYID2) - 03**

Bit	Bit Name	Default	Description
3.15-3.10	OUI_LSB	<101110>, RO/P	OUI Least Significant Bits Bit 19 to 24 of the OUI (00606E) are mapped to bit 15 to 10 of this register respectively
3.9-3.4	VNDR_MDL	<001000>, RO/P	Vendor Model Number Six bits of vendor model number mapped to bit 9 to 4 (most significant bit to bit 9)
3.3-3.0	MDL_REV	<000h>, RO/P	Model Revision Number Four bits of vendor model revision number mapped to bit 3 to 0 (most significant bit to bit 3)

**8.5 Auto-negotiation Advertisement Register (ANAR) - 04**

This register contains the advertised abilities of this DM9161 device as they will be transmitted to its link partner during Auto-negotiation.

Bit	Bit Name	Default	Description
4.15	NP	0,RO/P	Next page Indication 0 = No next page available 1 = Next page available The DM9161 has no next page, so this bit is permanently set to 0
4.14	ACK	0,RO	Acknowledge 1 = Link partner ability data reception acknowledged 0 = Not acknowledged The DM9161's auto-negotiation state machine will automatically control this bit in the outgoing FLP bursts and set it at the appropriate time during the auto-negotiation process. Software should not attempt to write to this bit.
4.13	RF	0, RW	Remote Fault 1 = Local device senses a fault condition 0 = No fault detected
4.12-4.11	Reserved	X, RW	Reserved Write as 0, ignore on read
4.10	FCS	0, RW	Flow Control Support 1 = Controller chip supports flow control ability 0 = Controller chip doesn't support flow control ability
4.9	T4	0, RO/P	100BASE-T4 Support 1 = 100BASE-T4 is supported by the local device 0 = 100BASE-T4 is not supported The DM9161 does not support 100BASE-T4 so this bit is permanently set to 0
4.8	TX_FDX	1, RW	100BASE-TX Full Duplex Support 1 = 100BASE-TX full duplex is supported by the local device 0 = 100BASE-TX full duplex is not supported
4.7	TX_HDX	1, RW	100BASE-TX Support 1 = 100BASE-TX half duplex is supported by the local device 0 = 100BASE-TX half duplex is not supported
4.6	10_FDX	1, RW	10BASE-T Full Duplex Support 1 = 10BASE-T full duplex is supported by the local device 0 = 10BASE-T full duplex is not supported
4.5	10_HDX	1, RW	10BASE-T Support 1 = 10BASE-T half duplex is supported by the local device 0 = 10BASE-T half duplex is not supported
4.4-4.0	Selector	<00001>, RW	Protocol Selection Bits These bits contain the binary encoded protocol selector supported by this node <00001> indicates that this device supports IEEE 802.3 CSMA/CD

**8.6 Auto-negotiation Link Partner Ability Register (ANLPAR) – 05**

This register contains the advertised abilities of the link partner when received during Auto-negotiation.

Bit	Bit Name	Default	Description
5.15	NP	0, RO	Next Page Indication 0 = Link partner, no next page available 1 = Link partner, next page available
5.14	ACK	0, RO	Acknowledge 1 = Link partner ability data reception acknowledged 0 = Not acknowledged The DM9161's auto-negotiation state machine will automatically control this bit from the incoming FLP bursts. Software should not attempt to write to this bit
5.13	RF	0, RO	Remote Fault 1 = Remote fault indicated by link partner 0 = No remote fault indicated by link partner
5.12-5.11	Reserved	0, RO	Reserved Read as 0, ignore on write
5.10	FCS	0, RO	Flow Control Support 1 = Controller chip supports flow control ability by link partner 0 = Controller chip doesn't support flow control ability by link partner
5.9	T4	0, RO	100BASE-T4 Support 1 = 100BASE-T4 is supported by the link partner 0 = 100BASE-T4 is not supported by the link partner
5.8	TX_FDX	0, RO	100BASE-TX Full Duplex Support 1 = 100BASE-TX full duplex is supported by the link partner 0 = 100BASE-TX full duplex is not supported by the link partner
5.7	TX_HDX	0, RO	100BASE-TX Support 1 = 100BASE-TX half duplex is supported by the link partner 0 = 100BASE-TX half duplex is not supported by the link partner
5.6	10_FDX	0, RO	10BASE-T Full Duplex Support 1 = 10BASE-T full duplex is supported by the link partner 0 = 10BASE-T full duplex is not supported by the link partner
5.5	10_HDX	0, RO	10BASE-T Support 1 = 10BASE-T half duplex is supported by the link partner 0 = 10BASE-T half duplex is not supported by the link partner
5.4-5.0	Selector	<00000>, RO	Protocol Selection Bits Link partner's binary encoded protocol selector

**8.7 Auto-negotiation Expansion Register (ANER)- 06**

6.15-6.5	Reserved	0, RO	Reserved Read as 0, ignore on write
6.4	PDF	0, RO/LH	Local Device Parallel Detection Fault PDF = 1: A fault detected via parallel detection function. PDF = 0: No fault detected via parallel detection function
6.3	LP_NP_ABLE	0, RO	Link Partner Next Page Able LP_NP_ABLE = 1: Link partner, next page available LP_NP_ABLE = 0: Link partner, no next page
6.2	NP_ABLE	0,RO/P	Local Device Next Page Able NP_ABLE = 1: DM9161, next page available NP_ABLE = 0: DM9161, no next page DM9161 does not support this function, so this bit is always 0
6.1	PAGE_RX	0, RO/LH	New Page Received A new link code word page received. This bit will be automatically cleared when the register (register 6) is read by management
6.0	LP_AN_ABLE	0, RO	Link Partner Auto-negotiation Able A "1" in this bit indicates that the link partner supports Auto-negotiation

**8.8 DAVIDCOM Specified Configuration Register (DSCR) - 16**

Bit	Bit Name	Default	Description
16.15	BP_4B5B	0,RW	Bypass 4B5B Encoding and 5B4B Decoding 1 = 4B5B encoder and 5B4B decoder function bypassed 0 = Normal 4B5B and 5B4B operation
16.14	BP_SCR	0, RW	Bypass Scrambler/Descrambler Function 1 = Scrambler and descrambler function bypassed 0 = Normal scrambler and descrambler operation
16.13	BP_ALIGN	0, RW	Bypass Symbol Alignment Function 1 = Receive functions (descrambler, symbol alignment and symbol decoding functions) bypassed. Transmit functions (symbol encoder and scrambler) bypassed 0 = Normal operation
16.12	BP_ADPOK	0, RW	BYPASS ADPOK Force signal detector (SD) active. This register is for debug only, not release to customer 1=Forced SD is OK, 0=Normal operation
16.11	REPEATER	(Pin#38),RW	Repeater/Node Mode The value of the Repeater/Node pin (38) is latched into this bit at power-up/reset 1 = Repeater mode 0 = Node mode
16.10	TX	1, RW	100BASE-TX Mode Control 1 = 100BASE-TX operation 0=100BASE-FX operation
16.9	FEF	0, Rw	Far End Fault Enable:



			Control the Far End Fault mechanism Associated with 100BASE-FX operation 1=Enable 0=Disable
16.8	RMII_Enable	(Pin#36), RW	Reduced MII Enable Select normal MII or reduced MII. The value of the RMII pin(36) is latched into this bit at power-up/reset 0 = Normal MII 1 = Enable Reduced MII
16.7	F_LINK_100	0, RW	Force Good Link in 100Mbps 0 = Normal 100Mbps operation 1 = Force 100Mbps good link status This bit is useful for diagnostic purposes
16.6	SPLED_CTL	0, RW	Speed LED Disable 0 = Normal SPEEDLED output to indicate speed status 1 = Disable SPEEDLED output and enable SD signal monitor (for internal debug). When this bit is set, it controls the SPEEDLED as 100BASE-X SD signal output .For debug only
16.5	COLLED_CTL	0, RW	Collision LED Enable 0 = FDX/COLLED output is configured to indicate Full/half duplex status 1 = FDX/COLLED output is configured to indicate Full-duplex/Collision status
16.4	RPDCTR-EN	1, RW	Reduced Power Down Control Enable This bit is used to enable automatic reduced power down 0 = Disable automatic reduced power down 1 = Enable automatic reduced power down
16.3	SMRST	0, RW	Reset State Machine When writes 1 to this bit, all state machines of PHY will be reset. This bit is self-clear after reset is completed
16.2	MFPSC	0, RW	MF Preamble Suppression Control MII frame preamble suppression control bit 1 = MF preamble suppression bit on 0 = MF preamble suppression bit off
16.1	SLEEP	0, RW	Sleep Mode Writing an 1 to this bit will cause PHY entering the Sleep mode and power down all circuit except oscillator and clock generator circuit. When waking up from Sleep mode (write this bit to 0), the configuration will go back to the state before sleep; but the state machine will be reset
16.0	RLOUT	0, RW	Remote Loopout Control When this bit is set to 1, the received data will loop out to the transmit channel. This is useful for bit error rate testing

**8.9 DAVICOM Specified Configuration and Status Register (DSCSR) - 17**

Bit	Bit Name	Default	Description																																																		
17.15	100FDX	1, RO	100M Full Duplex Operation Mode After auto-negotiation is completed, results will be written to this bit. If this bit is 1, it means the operation 1 mode is a 100M full duplex mode. The software can read bit [15:12] to see which mode is selected after auto-negotiation. This bit is invalid when it is not in the auto-negotiation mode																																																		
17.14	100HDX	1, RO	100M Half Duplex Operation Mode After auto-negotiation is completed, results will be written to this bit. If this bit is 1, it means the operation 1 mode is a 100M half duplex mode. The software can read bit [15:12] to see which mode is selected after auto-negotiation. This bit is invalid when it is not in the auto-negotiation mode																																																		
17.13	10FDX	1, RO	10M Full Duplex Operation Mode After auto-negotiation is completed, results will be written to this bit. If this bit is 1, it means the operation 1 mode is a 10M Full Duplex mode. The software can read bit [15:12] to see which mode is selected after auto-negotiation. This bit is invalid when it is not in the auto-negotiation mode																																																		
17.12	10HDX	1, RO	10M Half Duplex Operation Mode After auto-negotiation is completed, results will be written to this bit. If this bit is 1, it means the operation 1 mode is a 10M half duplex mode. The software can read bit [15:12] to see which mode is selected after auto-negotiation. This bit is invalid when it is not in the auto-negotiation mode																																																		
17.11-17.9	Reserved	0, RO	Reserved Read as 0, ignore on write																																																		
17.8-17.4	PHYADR[4:0]	(PHYADR), RW	PHY Address Bit 4:0 The first PHY address bit transmitted or received is the MSB of the address (bit 4). A station management entity connected to multiple PHY entities must know the appropriate address of each PHY																																																		
17.3-17.0	ANMB[3:0]	0, RO	Auto-negotiation Monitor Bits These bits are for debug only. The auto-negotiation status will be written to these bits <table border="1" style="margin-left: 20px;"> <thead> <tr> <th>B3</th> <th>b2</th> <th>b1</th> <th>B0</th> <th></th> </tr> </thead> <tbody> <tr> <td>0</td> <td>0</td> <td>0</td> <td>0</td> <td>In IDLE state</td> </tr> <tr> <td>0</td> <td>0</td> <td>0</td> <td>1</td> <td>Ability match</td> </tr> <tr> <td>0</td> <td>0</td> <td>1</td> <td>0</td> <td>Acknowledge match</td> </tr> <tr> <td>0</td> <td>0</td> <td>1</td> <td>1</td> <td>Acknowledge match fail</td> </tr> <tr> <td>0</td> <td>1</td> <td>0</td> <td>0</td> <td>Consistency match</td> </tr> <tr> <td>0</td> <td>1</td> <td>0</td> <td>1</td> <td>Consistency match fail</td> </tr> <tr> <td>0</td> <td>1</td> <td>1</td> <td>0</td> <td>Parallel detects signal_link_ready</td> </tr> <tr> <td>0</td> <td>1</td> <td>1</td> <td>1</td> <td>Parallel detects signal_link_ready fail</td> </tr> <tr> <td>1</td> <td>0</td> <td>0</td> <td>0</td> <td>Auto-negotiation completed successfully</td> </tr> </tbody> </table>	B3	b2	b1	B0		0	0	0	0	In IDLE state	0	0	0	1	Ability match	0	0	1	0	Acknowledge match	0	0	1	1	Acknowledge match fail	0	1	0	0	Consistency match	0	1	0	1	Consistency match fail	0	1	1	0	Parallel detects signal_link_ready	0	1	1	1	Parallel detects signal_link_ready fail	1	0	0	0	Auto-negotiation completed successfully
B3	b2	b1	B0																																																		
0	0	0	0	In IDLE state																																																	
0	0	0	1	Ability match																																																	
0	0	1	0	Acknowledge match																																																	
0	0	1	1	Acknowledge match fail																																																	
0	1	0	0	Consistency match																																																	
0	1	0	1	Consistency match fail																																																	
0	1	1	0	Parallel detects signal_link_ready																																																	
0	1	1	1	Parallel detects signal_link_ready fail																																																	
1	0	0	0	Auto-negotiation completed successfully																																																	



**8.10 10BASE-T Configuration/Status (10BTCSR) - 18**

Bit	Bit Name	Default	Description
18.15	Reserved	0, RO	Reserved Read as 0, ignore on write
18.14	LP_EN	1, RW	Link Pulse Enable 1 = Transmission of link pulses enabled 0 = Link pulses disabled, good link condition forced This bit is valid only in 10Mbps operation
18.13	HBE	1, RW	Heartbeat Enable 1 = Heartbeat function enabled 0 = Heartbeat function disabled When the DM9161 is configured for full duplex operation, this bit will be ignored (the collision/heartbeat function is invalid in full duplex mode)
18.12	SQUELCH	1, RW	Squelch Enable 1 = Normal squelch 0 = Low squelch
18.11	JABEN	1, RW	Jabber Enable Enables or disables the Jabber function when the DM9161 is in 10BASE-T full duplex or 10BASE-T transceiver loopback mode 1 = Jabber function enabled 0 = Jabber function disabled
18.10	10BT_SER	0, RW	10BASE-T GPSI Mode 1 = 10BASE-T GPSI mode selected 0 = 10BASE-T MII mode selected GPSI mode is not supported for 100Mbps operation
18.9-18.1	Reserved	0, RO	Reserved Read as 0, ignore on write
18.0	POLR	0, RO	Polarity Reversed When this bit is set to 1, it indicates that the 10Mbps cable polarity is reversed. This bit is automatically set and cleared by 10BASE-T module

**8.11 DAVICOM Specified Interrupt Register – 21**

Bit	Bit Name	Default	Description
21.15	INTR PEND	0, RO	Interrupt Pending Indicates that the interrupt is pending and is cleared by the current read. This bit shows the same result as bit 0. (INTR Status)
21.14-21.12	Reserved	0, RO	Reserved
21.11	FDX mask	1, RW	Full-duplex Interrupt Mask When this bit is set, the Duplex status change will not generate the interrupt
21.10	SPD mask	1, RW	Speed Interrupt Mask When this bit is set, the Speed status change will not generate the interrupt
21.9	LINK mask	1, RW	Link Interrupt Mask

			When this bit is set, the link status change will not generate the interrupt
21.8	INTR mask	1, RW	Master Interrupt Mask When this bit is set, no interrupts will be generated under any condition
21.7-21.5	Reserved	0, RO	Reserved
21.4	FDX change	0, RO/LH	Duplex Status Change Interrupt "1" indicates a change of duplex since last register read. A read of this register will clear this bit
21.3	SPD change	0, RO/LH	Speed Status Change Interrupt "1" indicates a change of speed since last register read. A read of this register will clear this bit
21.2	LINK change	0, RO/LH	Link Status Change Interrupt "1" indicates a change of link since last register read. A read of this register will clear this bit
21.1	Reserved	0, RO	Reserved
21.0	INTR status	0, RO/LH	Interrupt Status The status of MDINTR#. "1" indicates that the interrupt mask is off that one or more of the change bits are set. A read of this register will clear this bit

**8.12 DAVICOM Specified Receive Error Counter Register (RECR) – 22**

Bit	Bit Name	Default	Description
22.15-0	Rcv_Err_Cnt	0, RO	Receive Error Counter Receive error counter that increments upon detection of REER

**8.13 DAVICOM Specified Disconnect Counter Register (DISCR) – 23**

Bit	Bit Name	Default	Description
23.15-23.8	Reserved	0, RO	Reserved
23.7-23.0	Disconnect Counter	0, RO	Disconnect Counter that increments upon detection of disconnection

**8.14 DAVICOM Hardware Reset Latch State Register (RLSR) – 24**

Bit	Bit Name	Default	Description
13	LH_LEDST	0	TXCLK pin reset latch value
12	LH_CSTS	0	CABLESTS pin reset latch value
11	LH_RMII	0	COL pin reset latch value
10	LH_SCRAM	1	RXCLK pin reset latch value
9	LH_REPTR	0	RXDV pin reset latch value
8	LH_TSTMOD	0	RXER pin reset latch value
7	LH_OP2	1	LINKLED pin reset latch value
6	LH_OP1	1	SPOLED pin reset latch value
5	LH_OP0	1	FDXLED pin reset latch value



4	LH_PH4	0	CRS pin reset latch value
3	LH_PH3	0	RXD3 pin reset latch value
2	LH_PH2	0	RXD2 pin reset latch value
1	LH_PH1	0	RXD1 pin reset latch value
0	LH_PH0	0	RXD0 pin reset latch value

**9. DC and AC Electrical Characteristics**

**9.1 Absolute Maximum Ratings**

Symbol	Parameter	Min.	Max.	Unit	Conditions
DVDD, AVDD	Supply Voltage	-0.3	3.6	V	
VIN	DC Input Voltage (VIN)	-0.5	5.5	V	
VOUT	DC Output Voltage(VOUT)	-0.3	3.6	V	
Tstg	Storage Temperature Rang (Tstg)	-65	+125	°C	
TA	Ambient Temperature Range	0	70	°C	
Tc	Case Temperature Range	0	85	°C	@ TA = 70°C
LT	Lead Temp. (TL, Soldering, 10 sec.)	---	235	°C	

**9.2 Operating Conditions (VDD = 3.3V, GND = 0V; TA = 25°C)**

Symbol	Parameter	Min.	Max.	Unit	Conditions
DVDD, AVDD	Supply Voltage	3.135	3.465	V	
PD (Power Dissipation)	100BASE-TX	---	88	mA	3.3V
	100BASE-FX	---	25	mA	3.3V
	10BASE-T TX, normal activity traffic 50% utility.	---	70	mA	3.3V
	10BASE-T idle	---	30	mA	3.3V
	Auto-negotiation	---	45	mA	3.3V
	Power Reduced Mode (without cable)	---	18	mA	3.3V
	Power Down Mode	---	3	mA	3.3V

**Comments**

Stresses above those listed under “Absolute Maximum Ratings” may cause permanent damage to the device. These are stress ratings only. Functional operation of this device at these or any other

conditions above those indicated that in the operational sections of this specification is not implied. Exposure to absolute maximum rating conditions for extended periods may affect device reliability.

**9.3 DC Electrical Characteristics** (V<sub>DD</sub> = 3.3V, GND = 0V; T<sub>A</sub> = 25°C)

Symbol	Parameter	Min.	Typ.	Max.	Unit	Conditions
<b>TTL Inputs</b> (TXD0~TXD3, TXCLK, MDC, MDIO, TXEN, TXER, RXEN, TESTMODE, RMII, PHYAD0~4, OPMODE0-2, RPTR, BP4B5B, RESET#)						
V <sub>IL</sub>	Input Low Voltage	---	---	0.8	V	
V <sub>IH</sub>	Input High Voltage	2.0	---	---	V	
I <sub>IL</sub>	Input Low Leakage Current	---	---	10	µA	V <sub>IN</sub> = 0.4V
I <sub>IH</sub>	Input High Leakage Current	---	---	-10	µA	V <sub>IN</sub> = 2.7V
<b>MII TTL Outputs</b> (RXD0-RXD3, RXDV, RXER, CRS, COL, MDIO)						
V <sub>OL</sub>	Output Low Voltage	---	---	0.4	V	I <sub>OL</sub> = 4mA
V <sub>OH</sub>	Output High Voltage	2.4	---	---	V	I <sub>OH</sub> = -4mA
<b>Non-MII TTL Outputs</b> (LINKLED#, SPEEDLED#, FDXLED#, MDINTR#)						
V <sub>OL</sub>	Output Low Voltage	---	---	0.4	V	I <sub>OL</sub> = 2mA
V <sub>OH</sub>	Output High Voltage	2.4	---	---	V	I <sub>OH</sub> = -2mA
<b>Receiver</b>						
V <sub>ICM</sub>	RX+/RX- Common mode Input Voltage	---	1.2	---	V	100 Ω Termination Across
<b>Transmitter</b>						
V <sub>TD100</sub>	100TX+/- Differential Output Voltage	1.9	2.0	2.1	V	Peak to Peak
I <sub>TD100</sub>	100TX+/- Differential Output Current	19	20	21	mA	
V <sub>OH</sub>	PECL Output Voltage – High	V <sub>CC</sub> -1.05		V <sub>CC</sub> -0.88	V	
V <sub>OL</sub>	PECL Output Voltage – Low	V <sub>CC</sub> -1.81		V <sub>CC</sub> -1.62	V	
V <sub>IH</sub>	PECL Input Voltage – High	V <sub>CC</sub> -1.16		V <sub>CC</sub> -0.88	V	
V <sub>IL</sub>	PECL Input Voltage – Low	V <sub>CC</sub> -1.81		V <sub>CC</sub> -1.48	V	
I <sub>FD100</sub>	100FX+/- Differential Output Current	17	18	19	mA	

**9.4 AC Electrical Characteristics & Timing Waveforms**
**9.4.1 TP Interface**

Symbol	Parameter	Min.	Typ.	Max.	Unit	Conditions
t <sub>TR/F</sub>	100TX+/- Differential Rise/Fall Time	3.0	---	5.0	ns	
t <sub>TM</sub>	100TX+/- Differential Rise/Fall Time Mismatch	0	---	0.5	ns	
t <sub>TDC</sub>	100TX+/- Differential Output Duty Cycle Distortion	0	---	0.5	ns	
t <sub>T/T</sub>	100TX+/- Differential Output Peak-to-Peak Jitter	0	---	1.4	ns	
XOST	100TX+/- Differential Voltage Overshoot	0	---	5	%	

**9.4.2 Oscillator/Crystal Timing**

Symbol	Parameter	Min.	Typ.	Max.	Unit	Conditions
tCKC	OSC Cycle Time	39.998	40	40.002	ns	50ppm
tPWH	OSC Pulse Width High	16	20	24	ns	
tPWL	OSC Pulse Width Low	16	20	24	ns	

**9.4.3 MDC/MDIO Timing**

Symbol	Parameter	Min.	Typ.	Max.	Unit	Conditions
t <sub>0</sub>	MDC Cycle Time	80	---	---	ns	
t <sub>1</sub>	MDIO Setup Before MDC	10	---	---	ns	When OUTPUT By STA
t <sub>2</sub>	MDIO Hold After MDC	10	---	---	ns	When OUTPUT By STA
t <sub>3</sub>	MDC To MDIO Output Delay	0	---	300	ns	When OUTPUT By DM9161

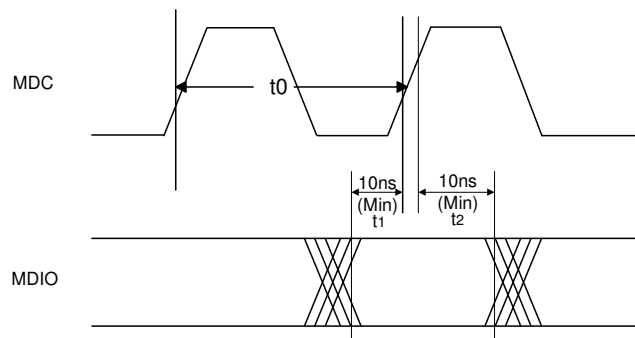
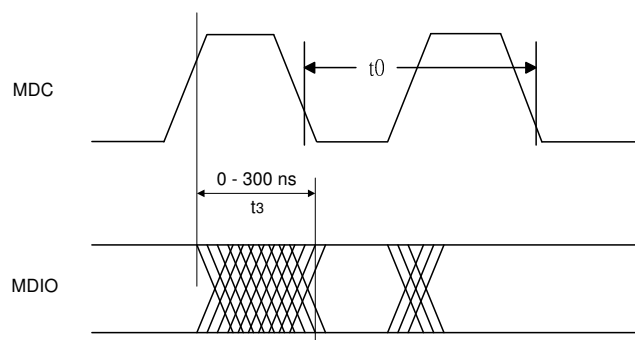
**9.4.4 MDIO Timing When OUTPUT by STA**

**9.4.5 MDIO Timing When OUTPUT by DM9161**

**9.4.6 100BASE-TX Transmit Timing Parameters**

Symbol	Parameter	Min.	Typ.	Max.	Unit	Conditions
tTXc	TXCLK Cycle Time	39.998	40	40.002	ns	50ppm
tTXh, tTXl	TXCLK High/Low Time	16	20	24	ns	
tTX <sub>s</sub>	TXD [0:3], TXEN, TXER Setup To TXCLK High	12	---	---	ns	
tTX <sub>h</sub>	TXD [0:3], TXEN, TXER Hold From TXCLK High	0	---	---	ns	
tTXOD	TXCLK to Output Delay			25	ns	
t1	TXEN Sampled To CRS Asserted	---	4	---	BT	
t2	TXEN Sampled To CRS De-asserted	---	4	---	BT	
tTX <sub>pd</sub>	TXEN Sampled To TX+/- Out (Tx Latency)	---	8	---	BT	
tTX <sub>rf</sub>	100TX Driver Rise/Fall Time	3	4	5	ns	90% To 10%, Into 100ohm Differential

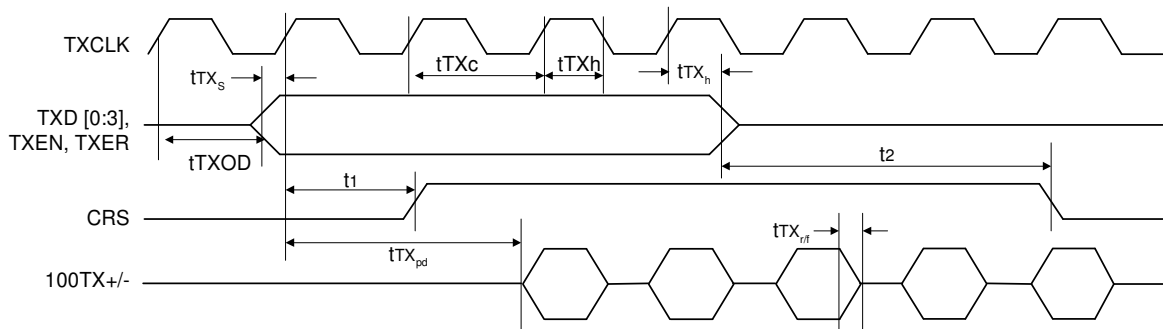
Note 1. Typical values are at 25°C and are for design aid only; not guaranteed and not subject to production testing.

**9.4.7 100BASE-TX Transmit Timing Diagram**

**9.4.8 100BASE-TX Receive Timing Parameters**

Symbol	Parameter	Min.	Typ.	Max.	Unit	Conditions
tRXc	RXCLK Cycle Time	39.996	40	40.004		
tRXh, tRXl	RXCLK High/Low Time	16	20	24		
tRX <sub>s</sub>	RXD [0:3], RXDV, RXER Setup To RXCLK High	10	-	-	ns	
tRX <sub>h</sub>	RXD [0:3], RXDV, RXER Hold From RXCLK High	10	-	-	ns	
tRX <sub>pd</sub>	RX+/- In To RXD [0:3] Out (Rx Latency)	-	15	-	BT	
t1	CRS Asserted To RXD [0:3], RXDV, RXER	-	4	-	BT	
t2	CRS De-asserted To RXD [0:3], RXDV, RXER	-	0	-	BT	
t3	RX+/- In To CRS Asserted	10	-	14	BT	
t4	RX+/- Quiet To CRS De-asserted	14	-	18	BT	
t5	RX+/- In To COL De-Asserted	14	-	18	BT	

<sup>1</sup>. Typical values are at 25°C and are for design aid only; not guaranteed and not subject to production testing.

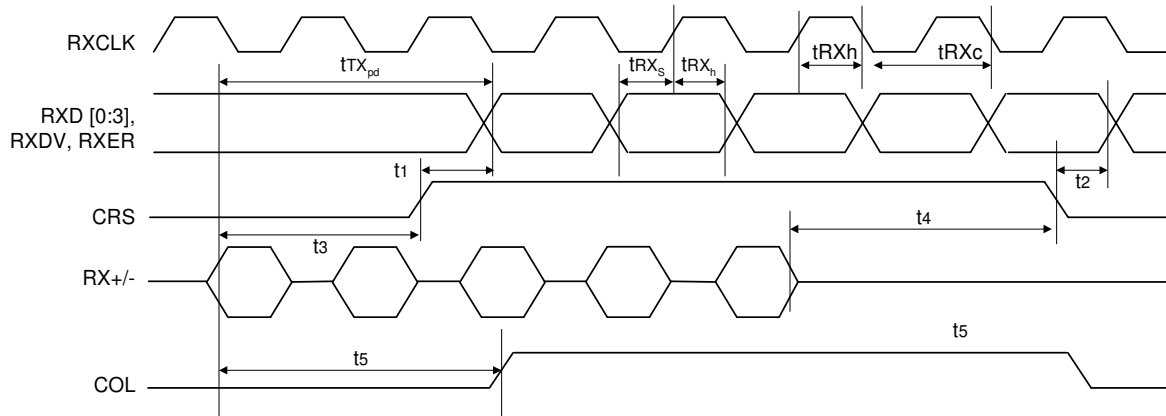
**9.4.9 MII 100BASE-TX Receive Timing Diagram**

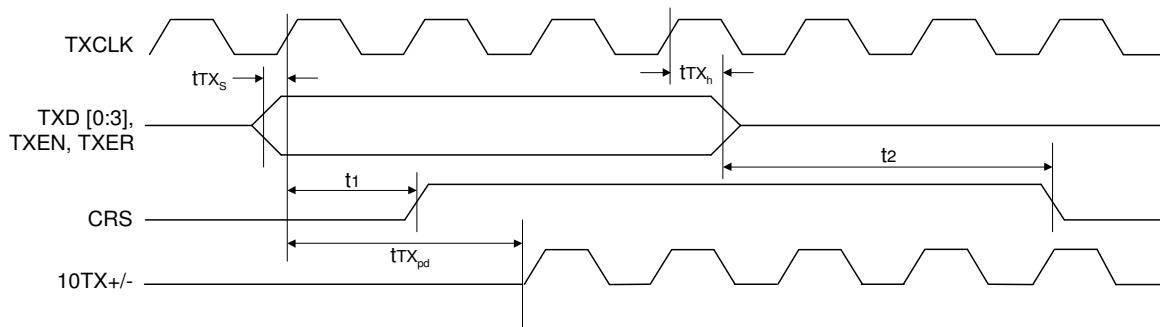

**9.4.10 MII 10BASE-T Nibble Transmit Timing Parameters**

Symbol	Parameter	Min.	Typ.	Max.	Unit	Conditions
$t_{TX_s}$	TXD[0:3], TXEN, TXER Setup To TXCLK High	5	---	---	ns	
$t_{TX_h}$	TXD[0:3], TXEN, TXER Hold From TXCLK High	5	---	---	ns	
$t_1$	TXEN Sampled To CRS Asserted	---	2	4	BT	
$t_2$	TXEN Sampled To CRS De-asserted	---	15	20	BT	
$t_{TX_{pd}}$	TXEN Sampled To 10TXO Out (Tx Latency)	---	2	4	BT	

**9.4.11 MII 10BASE-T Nibble Transmit Timing Diagram**

**9.4.12 MII 10BASE-T Receive Nibble Timing Parameters**

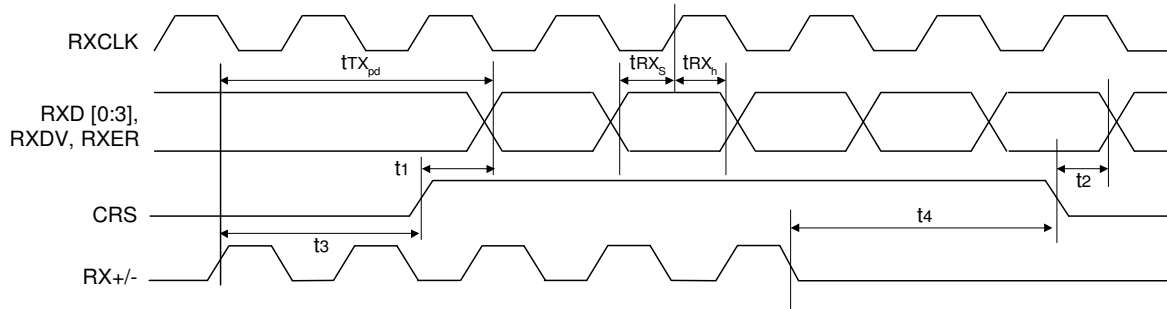
Symbol	Parameter	Min.	Typ.	Max.	Unit	Conditions
$t_{RX_s}$	RXD [0:3], RXDV, RXER Setup To RXCLK High	5	---	---	ns	
$t_{RX_h}$	RXD [0:3], RXDV, RXER Hold From RXCLK High	5	---	---	ns	
$t_{RX_{pd}}$	RXI In To RXD [0:3] Out (Rx Latency)	---	7	---	BT	
$t_1$	CRS Asserted To RXD [0:3], RXDV, RXER	1	14	20	BT	
$t_2$	CRS De-asserted To RXD [0:3], RXDV, RXER	---	---	3	BT	
$t_3$	RXI In To CRS Asserted	1	2	4	BT	
$t_4$	RXI Quiet To CRS De-asserted	1	10	15	BT	

**9.4.13 MII 10BASE-T Receive Nibble Timing Diagram**

**9.4.14 Auto-negotiation and Fast Link Pulse Timing Parameters**

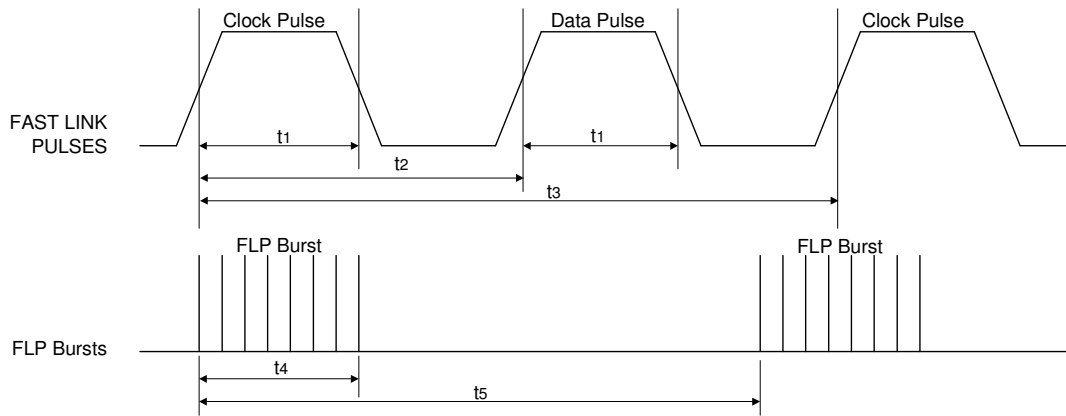
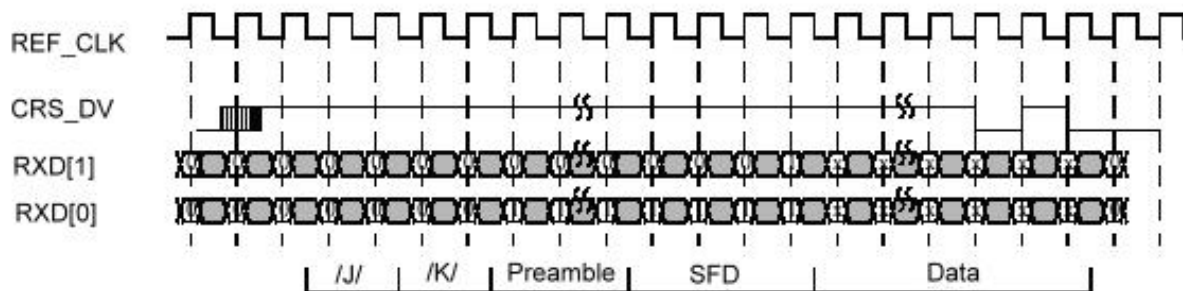
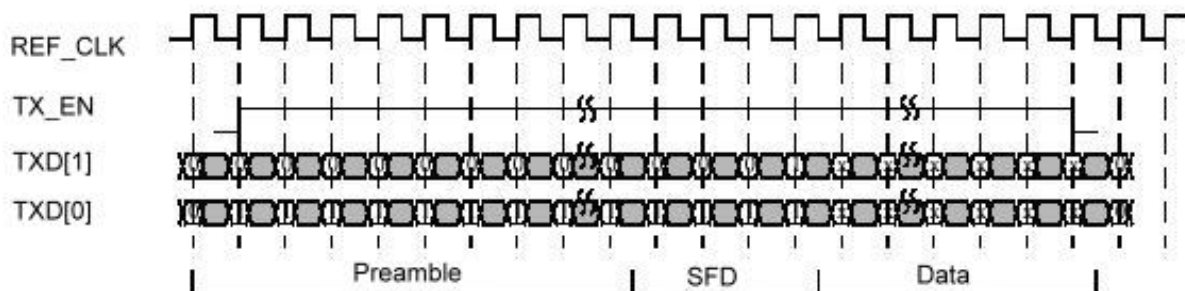
Symbol	Parameter	Min.	Typ.	Max.	Unit	Conditions
$t_1$	Clock/Data Pulse Width	---	100	---	ns	
$t_2$	Clock Pulse To Data Pulse Period	55.5	62.5	69.5	us	DATA = 1
$t_3$	Clock Pulse To Clock Pulse Period	111	125	139	us	
$t_4$	FLP Burst Width	-	2	-	ms	
$t_5$	FLP Burst To FLP Burst Period	8		24	ms	
-	Clock/Data Pulses in a Burst	17		33	pulse	

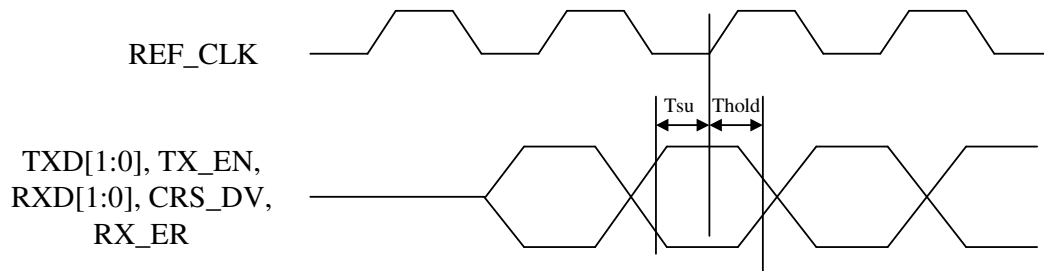
**9.4.15 Auto-negotiation and Fast Link Pulse Timing Diagram**

**9.4.16 RMII Receive Timing Diagram**

**100 Mb/s Reception with no errors**
**9.4.17 RMII Transmit Timing Diagram**

**100 Mb/s Transmission**

**9.4.18 RMII Timing Diagram**

**9.4.19 RMII Timing Parameter**

Symbol	Parameter	Min.	Typ.	Max.	Unit	Conditions
	REF_CLK Frequency		50		MHz	
	REF_CLK Duty Cycle	35		65	%	
Tsu	TXD[1:0], TX_EN, RXD[1:0], CRS_DV, RX_ER Data Setup to REF_CLK rising edge	4			ns	
Thold	TXD[1:0], TX_EN, RXD[1:0], CRS_DV, RX_ER Data hold from REF_CLK rising edge	2			ns	

### 10. Application Notes

#### 10.1 Network Interface Signal Routing

Place the transformer as close as possible to the RJ-45 connector. Place all the 50Ω resistors as close as possible to the DM9161 RX± and TX± pins. Traces routed from RX± and TX± to the transformer should run in close pairs directly to the transformer. The designer should be careful not to cross the transmit and receive pairs. As always, vias should be avoided as much as possible. The network interface should be void of any signals other than the TX± and RX± pairs between the RJ-45 to the transformer and the transformer to the DM9161. There should be no power or

ground planes in the area under the network side of the transformer to include the area under the RJ-45 connector (Refer to Figure 10-1 and 10-2). Keep chassis ground away from all active signals. The RJ-45 connector and any unused pins should be tied to chassis ground through a resistor divider network and a 2KV bypass capacitor.

The Band Gap resistor should be placed as physically close to pin 47 and 48 as possible (refer to Figure 10-1 and 10-2). The designer should not run any high-speed signal near the Band Gap resistor placement.

#### 10.2 10Base-T/100Base-TX Application

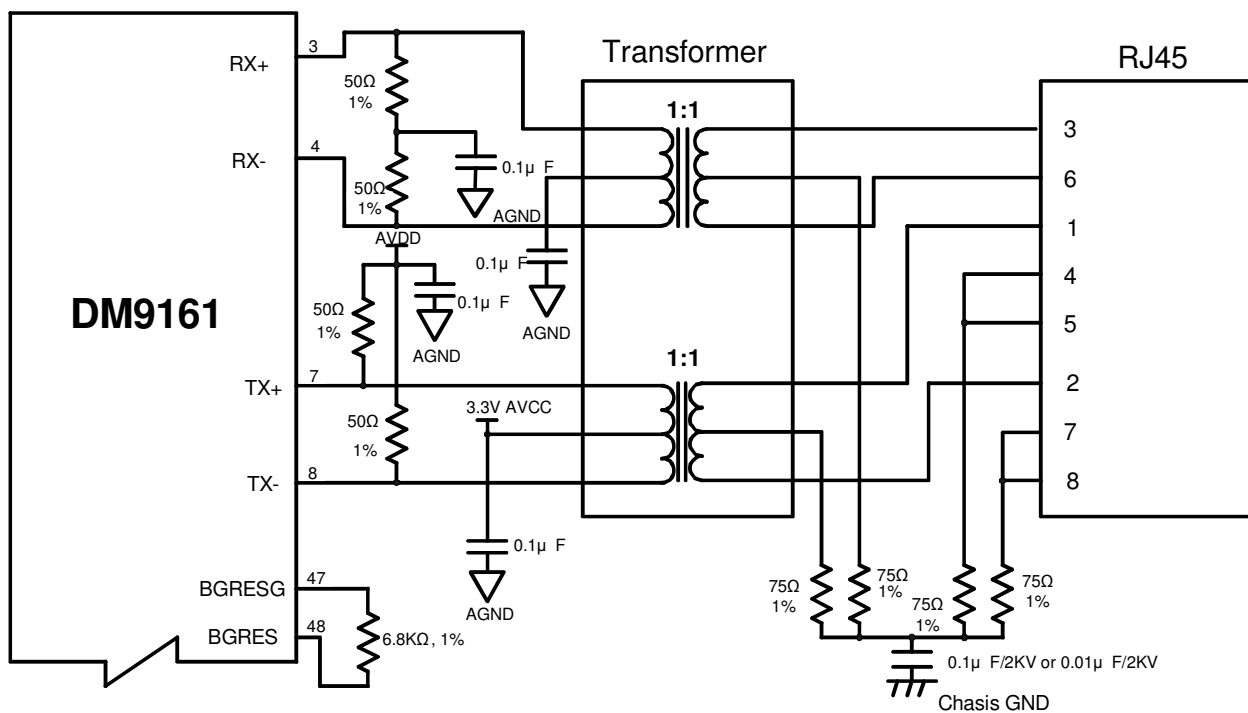

Figure 10-1

### 10.3 10Base-T/100Base-TX (Power Reduction Application)

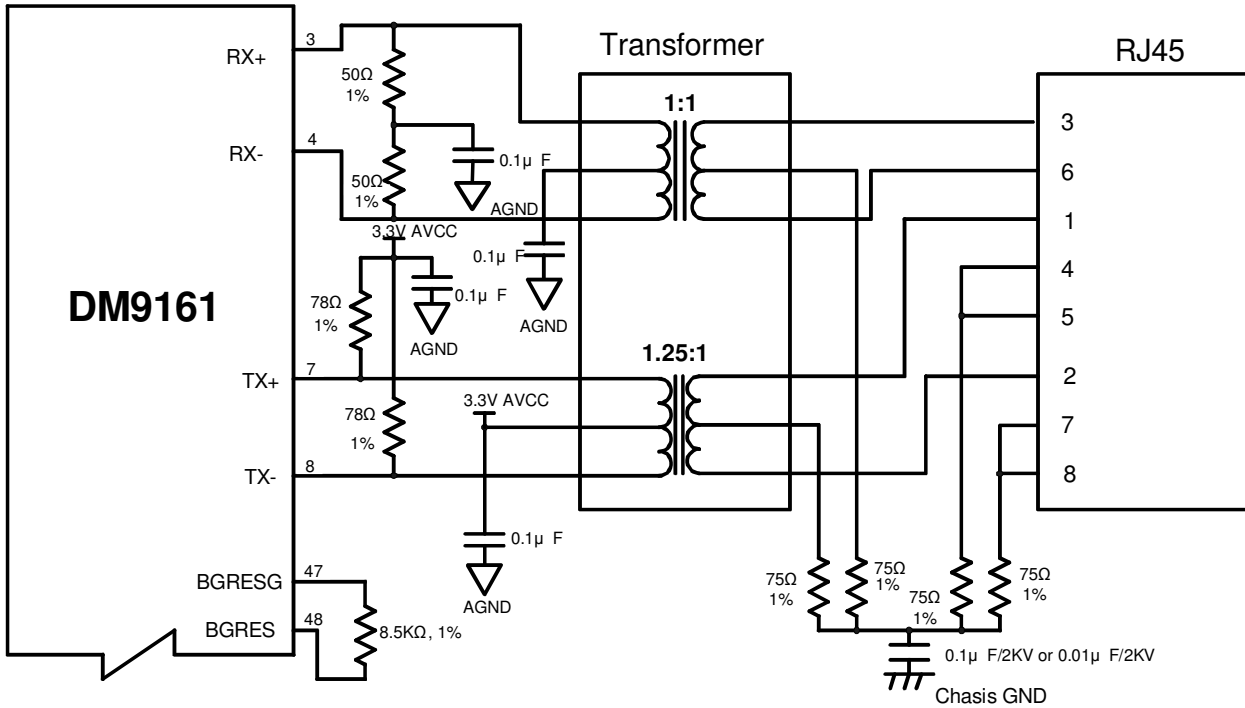

Figure 10-2

## 10.4 100Base-FX Application

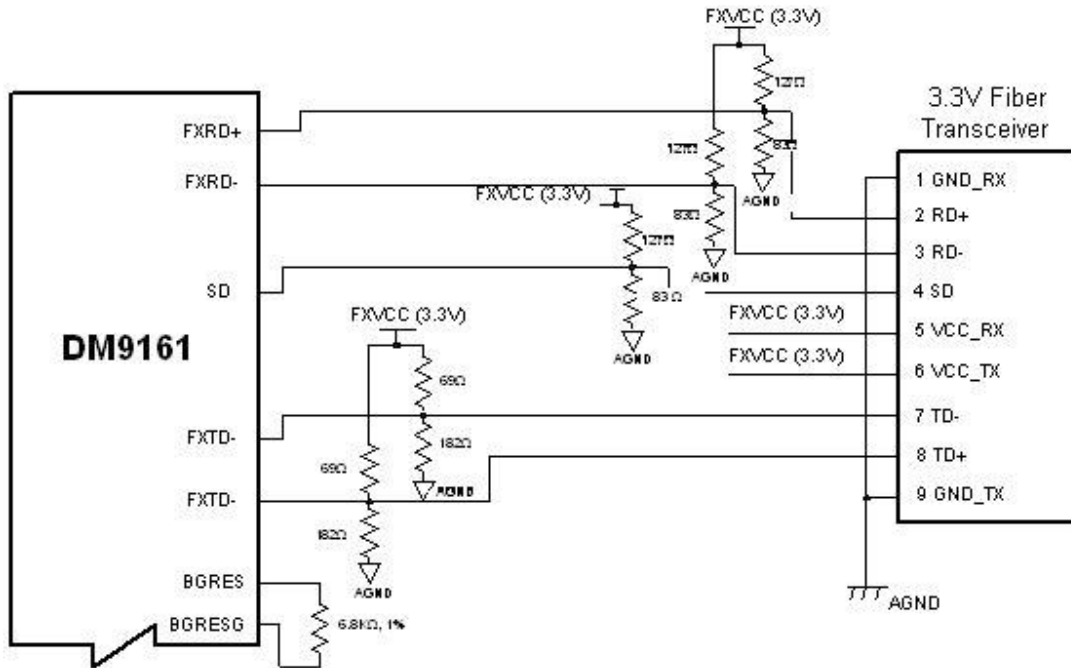

Figure 10-3

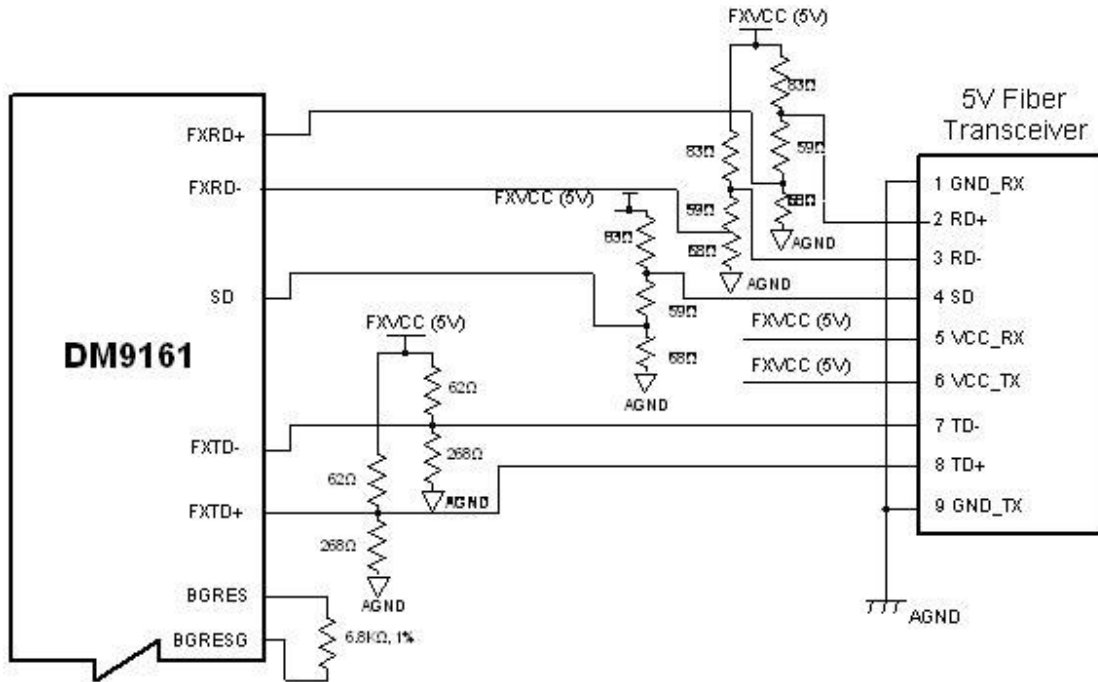
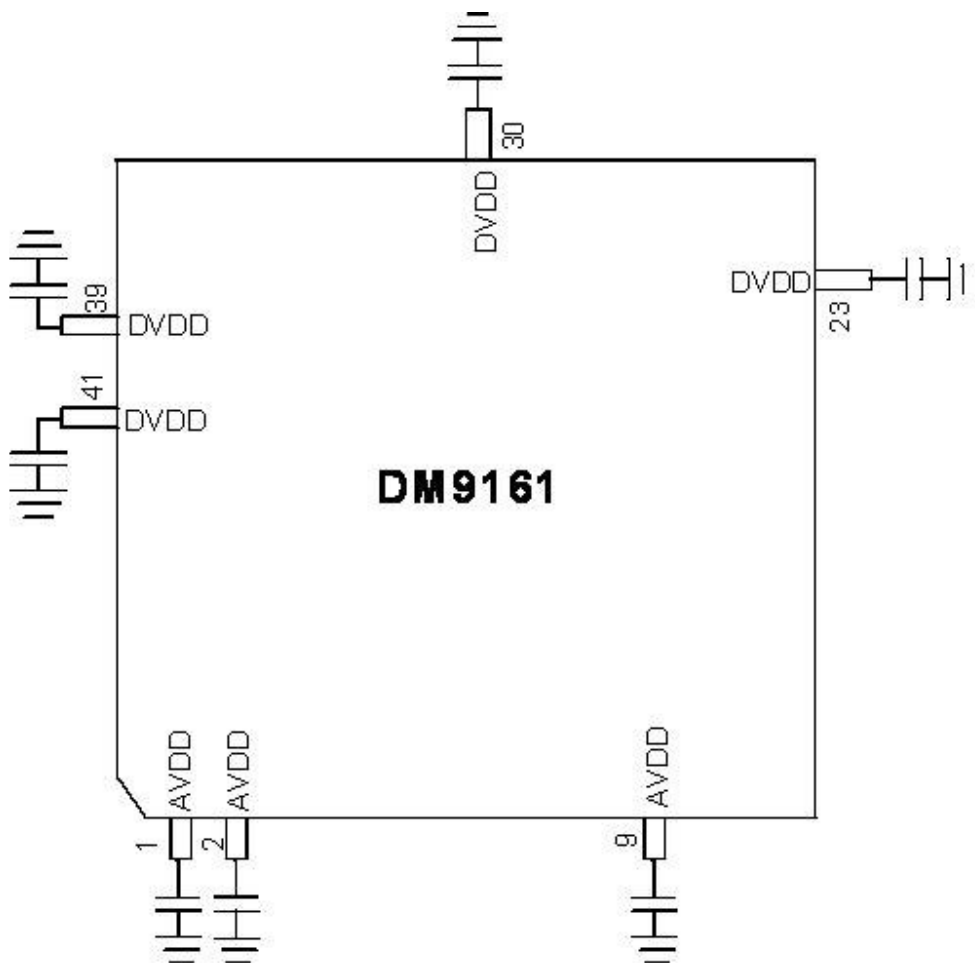

Figure 10-4

**10.5 Power Decoupling Capacitors**

Davicom Semiconductor recommends that all the decoupling capacitors of all power supply pins are placed as close as possible to the power pads of the DM9161 (The

best distance to place is < 3mm from pin). The recommended decoupling capacitance is 0.1 $\mu$ F or 0.01 $\mu$ F, as required by the design layout.

**Figure 10-5**

### 10.6 Ground Plane Layout

A single ground plane approach is recommended to minimize EMI. Bad ground plane partitioning can cause more EMI emissions that could make the network interface

card not compliant with specific FCC regulations (part 15). Figure 10-6 and 10-7 shows a recommended ground layout scheme.

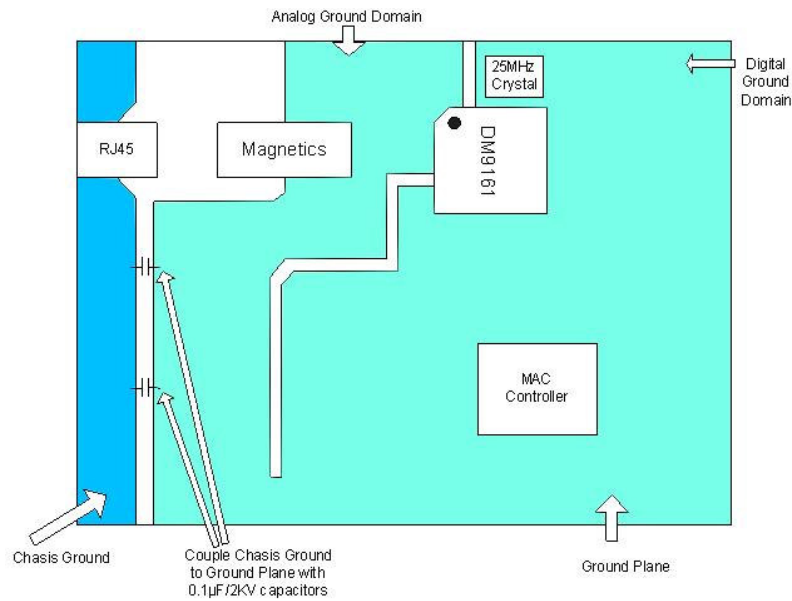

Figure 10-6

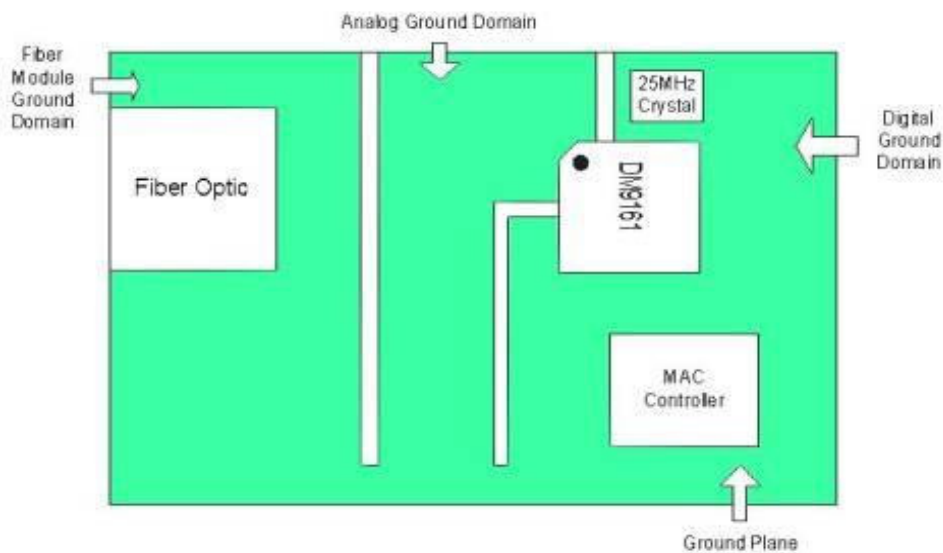
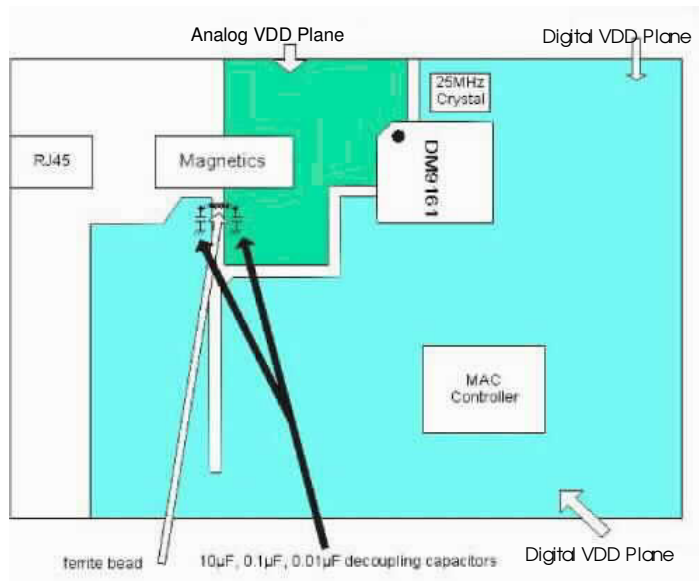

Figure 10-7

**10.7 Power Plane Partitioning**

The power planes should be approximately illustrated in Figure 10-8 and 10-9. The ferrite bead used should have an impedance at least 75Ω at 100MHz. A suitable bead is the Panasonic surface mount bead, part number

EXCCL4532U or an equivalent. 10μF, 0.1μF, and 0.01μF electrolytic bypass capacitors should be connected between DVDD and DGND at each side of the ferrite bead.



**Figure 10-8**

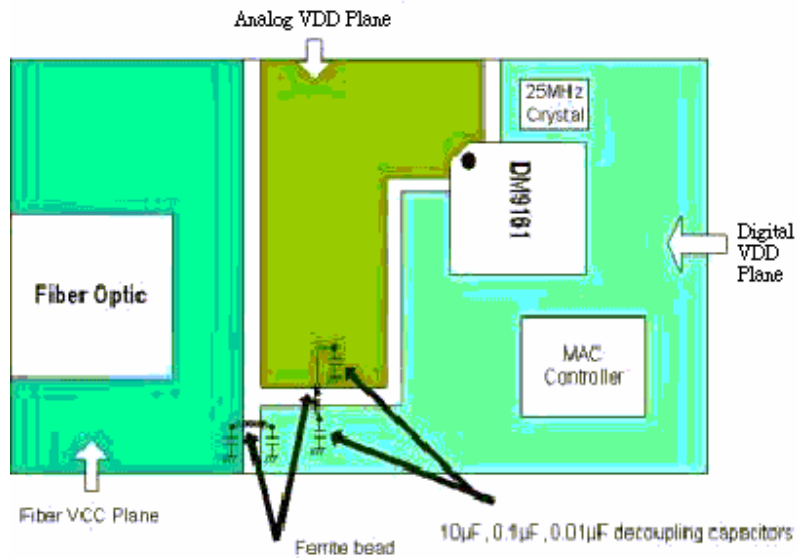

**Figure 10-9**

### 10.8 Magnetics Selection Guide

Refer to Table 10-2 for transformer requirements. Transformers meeting these requirements are available from a variety of magnetic manufacturers. Designers should

test and qualify all magnetics before using them in an application. The transformers listed in Table 10-2 are electrical equivalents, but may not be pin-to-pin equivalents.

Manufacturer	Part Number
<b>Pulse Engineering</b>	PE-68515, H1078, H1012, H1102
<b>Delta</b>	LF8200, LF8221X
<b>YCL</b>	20PMT04, 20PMT05
<b>Halo</b>	TG22-3506ND, TD22-3506G1, TG22-S010ND TG22-S012ND
<b>Nano Pulse Inc.</b>	NPI 6181-37, NPI 6120-30, NPI 6120-37 NPI 6170-30
<b>Fil-Mag</b>	PT41715
<b>Bel Fuse</b>	S558-5999-01
<b>Valor</b>	ST6114, ST6118
<b>Macronics</b>	HS2123, HS2213

**Table 10-2**

### 10.9 Crystal Selection Guide

A crystal can be used to generate the 25MHz reference clock instead of an oscillator. The crystal must be a fundamental type, series-resonant, connected to XT1 and

XT2, and shunt to ground with 22pF capacitors. (See Figure 10-10)

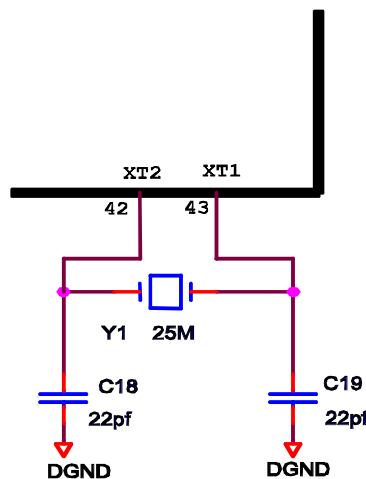
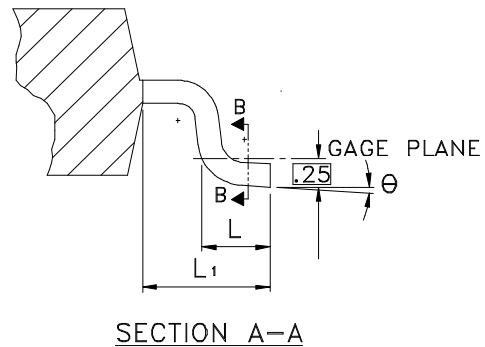
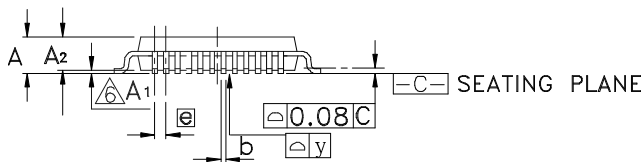
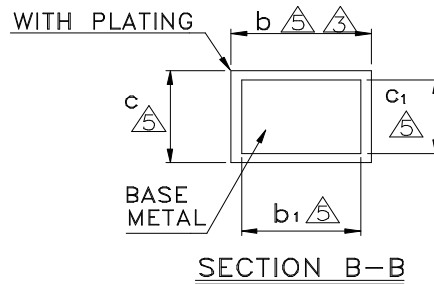
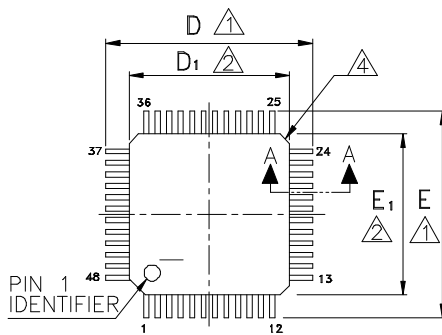

**Figure 10-10**  
**Crystal Circuit Diagram**

## 11. Package Information

### LQFP 48L (F.P. 2mm) Outline Dimensions

unit: inches/mm



Symbol	Dimensions in inches			Dimensions in mm		
	Min.	Nom.	Max.	Min.	Nom.	Max.
A	-	-	0.063	-	-	1.6
A1	0.002	-	0.006	0.05	-	0.15
A2	0.053	0.055	0.057	1.35	1.40	1.45
b	0.007	0.009	0.011	0.17	0.22	0.27
b1	0.007	0.008	0.009	0.17	0.20	0.23
C	0.004	-	0.008	0.09	-	0.20
C1	0.004	-	0.006	0.09	-	0.16
D	0.354BSC			9.00BSC		
D1	0.276BSC			7.00BSC		
E	0.354BSC			9.00BSC		
E1	0.276BSC			7.00BSC		
[e]	0.020BSC			0.50BSC		
L	0.018	0.024	0.030	0.45	0.60	0.75
L1	0.039REF			1.00REF		
y	0.003MAX			0.08MAX		

$\theta$	0°	3.5°	7°	0°	3.5°	7°
----------	----	------	----	----	------	----

**Notes:**

- To be determined at seating plane.
- Dimensions D1 and E1 do not include mold protrusion. D1 and E1 are maximum plastic body size dimensions including mold mismatch.
- Dimensions b does not include dambar protrusion. Total in excess of the b dimension at maximum material condition. Dambar cannot be located on the lower radius of the foot.
- Exact shape of each corner is optional.
- These dimensions apply to the flat section of the lead between 0.10mm and 0.25mm from the lead tip.
- A1 is defined as the distance from the seating plane to the lowest point of the package body.
- Controlling dimension: millimeter.
- Reference documents: JEDEC MS-026, BBC.



# DM9161

## 10/100 Mbps Fast Ethernet Physical Layer TX/FX Single Chip Transceiver

### 12. Order Information

Part Number	Pin Count	Package
DM9161E	48	LQFP

#### Disclaimer

The information appearing in this publication is believed to be accurate. Integrated circuits sold by DAVICOM Semiconductor are covered by the warranty and patent indemnification, and the provisions stipulated in the terms of sale only. DAVICOM makes no warranty, express, statutory, implied or by description, regarding the information in this publication or regarding the freedom of the described chip(s) from patent infringement. FURTHER, DAVICOM MAKES NO WARRANTY OF MERCHANTABILITY OR FITNESS FOR ANY PURPOSE. DAVICOM reserves the right to halt production or alter the specifications and prices at any time without notice. Accordingly, the reader is cautioned to verify that the data sheets and other information in this publication are current before placing orders. Products described herein are intended for use in normal commercial applications. Applications involving unusual environmental or reliability requirements, e.g. military equipment or medical life support equipment, are specifically not recommended without additional processing by DAVICOM for such applications. Please note that application circuits illustrated in this document are for reference purposes only.

### Contact Windows

For additional information about DAVICOM products, contact the sales department at:

#### Headquarters

Hsin-chu Office:  
No. 6 Li-Hsin Rd. VI, Science Park,  
Hsin-Chu, Taiwan, R.O.C.  
TEL: + 886-3-5798797  
FAX: + 886-3-5646929  
<http://www.davicom.com.tw>

#### WARNING

Conditions beyond those listed for the absolute maximum may destroy or damage the products. In addition, conditions for sustained periods at near the limits of the operating ranges will stress and may temporarily (and permanently) affect and damage structure, performance and/or function.

DAVICOM's terms and conditions printed on the order acknowledgment govern all sales by DAVICOM. DAVICOM will not be bound by any terms inconsistent with these unless DAVICOM agrees otherwise in writing. Acceptance of the buyer's orders shall be based on these terms.

#### Company Overview

DAVICOM Semiconductor, Inc. develops and manufactures integrated circuits for integration into data communication products. Our mission is to design and produce IC products that are the industry's best value for Data, Audio, Video, and Internet/Intranet applications. To achieve this goal, we have built an organization that is able to develop chipsets in response to the evolving technology requirements of our customers while still delivering products that meet their cost requirements.

#### Products

We offer only products that satisfy high performance requirements and which are compatible with major hardware and software standards. Our currently available and soon to be released products are based on our proprietary designs and deliver high quality, high performance chipsets that comply with modern communication standards and Ethernet networking standards.