

# EAP series

EAP -10 -472 -□

① ② ③ ④

- ① Model Name
- ② Rated Current
- ③ Line to ground capacitor code: See table 1.1.

table 1.1 Line to ground capacitor code

Code	Leakage Current (Input 125/250V 60Hz)	Line to ground capacitor (nominal value)
000	5 $\mu$ A/ 10 $\mu$ A max	Not Provided
101	12.5 $\mu$ A/ 25 $\mu$ A max	100pF
221	25 $\mu$ A/ 50 $\mu$ A max	220pF
331	37.5 $\mu$ A/ 75 $\mu$ A max	330pF
471	50 $\mu$ A/100 $\mu$ A max	470pF
681	75.5 $\mu$ A/150 $\mu$ A max	680pF
102	0.13mA/0.25mA max	1000pF
222	0.25mA/0.5 mA max	2200pF
332	0.38mA/0.75mA max	3300pF
472	0.5 mA/1.0 mA max	4700pF

\* When the line to ground capacitor code is different, the attenuation characteristic is different.

- ④ Options
- D: DIN rail installation type

\* The dimensions change when the option is set. Refer to External view.

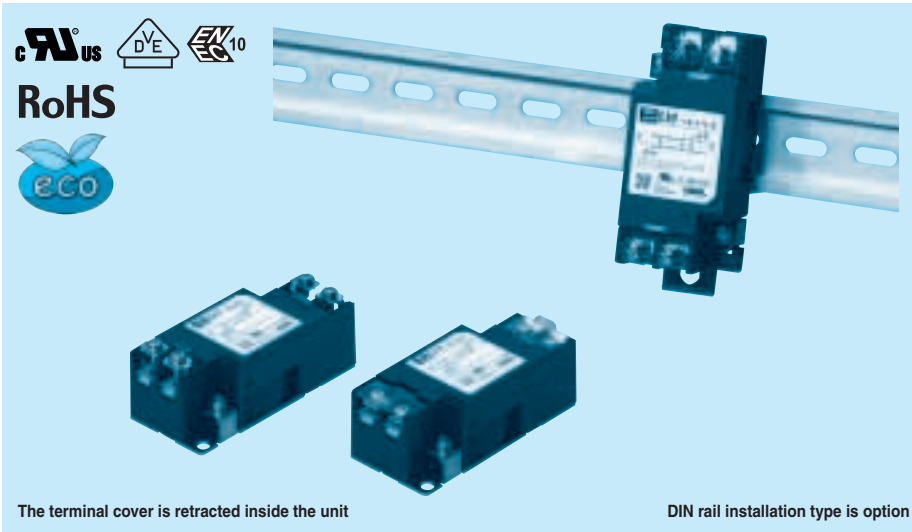

The terminal cover is retracted inside the unit

DIN rail installation type is option

## Features of EAP series

### Small, High-voltage pulses common mode EMI/EMC Filters (1-Stage filter)

- Single Phase 250 VAC
  - Small-size
  - Quick and easy push-down terminal
- Just connect the wires, push-down and tighten the screws with a screwdriver**

### Specifications

No.	Items	EAP-03-472	EAP-06-472	EAP-10-472	EAP-16-472	EAP-20-472	EAP-30-472
1	Rated Voltage[V]	AC 1 $\phi$ 250 / DC250					
2	Rated Current[A]	3	6	10	16	20	30
3	Test Voltage (Terminal-Mounting Plate)	2,500 VAC (Cutoff Current = 20mA), 1minute at room temperature and humidity					
4	Isolation Resistance (Terminal-Mounting Plate)	500 VDC 500M $\Omega$ min at room temperature and humidity					
5	Leakage current 125/250V 60Hz	0.5mA/1.0mA max					
6	DC resistance	180m $\Omega$ max	110m $\Omega$ max	40m $\Omega$ max	20m $\Omega$ max	10m $\Omega$ max	6m $\Omega$ max
7	Safety agency approval temperatures	-25 to +85°C (Refer to Derating Curve)					
8	Operating temperature	-40 to +85°C (Refer to Derating Curve)					
9	Operating humidity	20 to 95%RH (Non condensing)					
10	Storage temperature/humidity	-40 to +85°C/20 to 95%RH (Non condensing)					
11	Vibration	10 to 55Hz, 19.6m/s <sup>2</sup> (2G), 3min. Period, 1hour each X, Y and Z axis					
12	Impact	196.1m/s <sup>2</sup> (20G), 11ms Once each X, Y and Z axis					
13	Safety agency approvals	UL1283, CSA C22.2 No.8 (C-UL), DIN EN60939 VDE0565 Teil3-1, ENEC (At only AC input)					
14	Case size (without projection) /Weight	39 X 30 X 85 mm [1.54 X 1.18 X 3.35 inches] (W X H X D) /170g max (Option : -D refer to external view)					

### Circuit Diagram

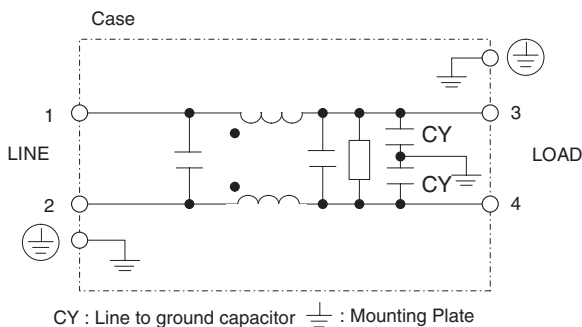

### Derating Curve

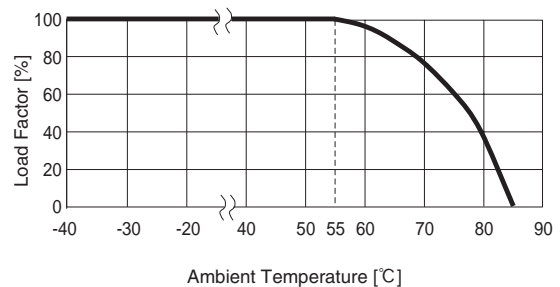

## External view

This product is shipped in the following condition, because it is equipped with push-down terminals.

- ① The terminal cover is retracted inside the unit.
- ② The screws for connecting the terminals are held in the up right position.

### Standard Type

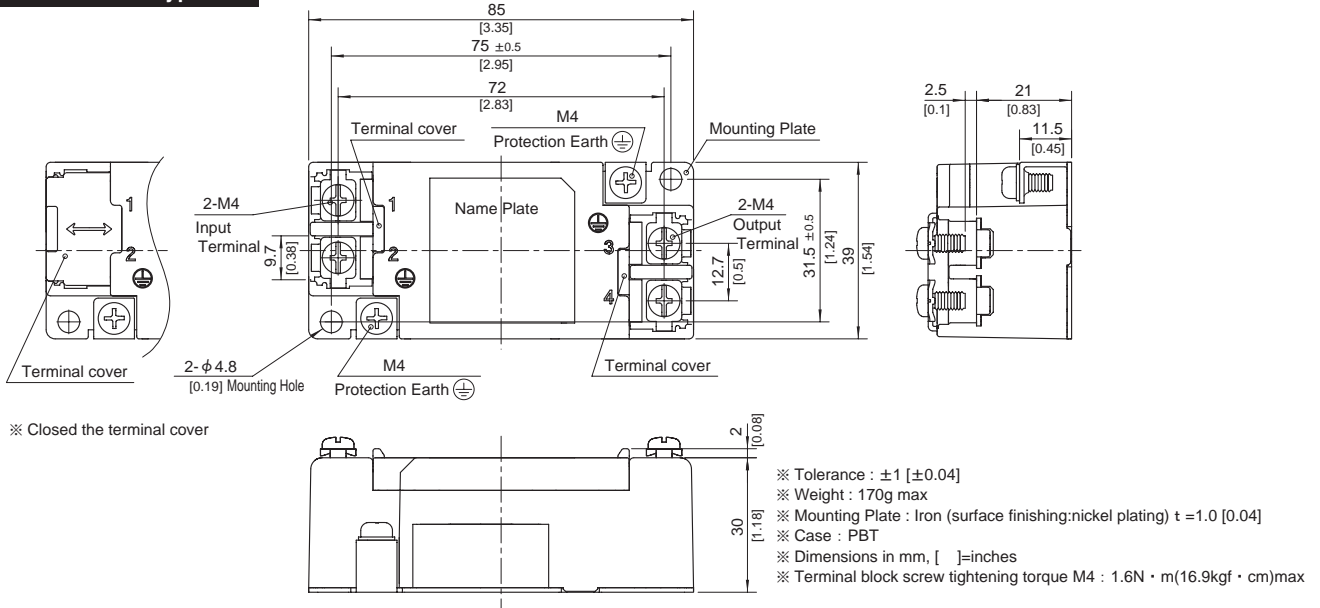

### DIN rail installation Type

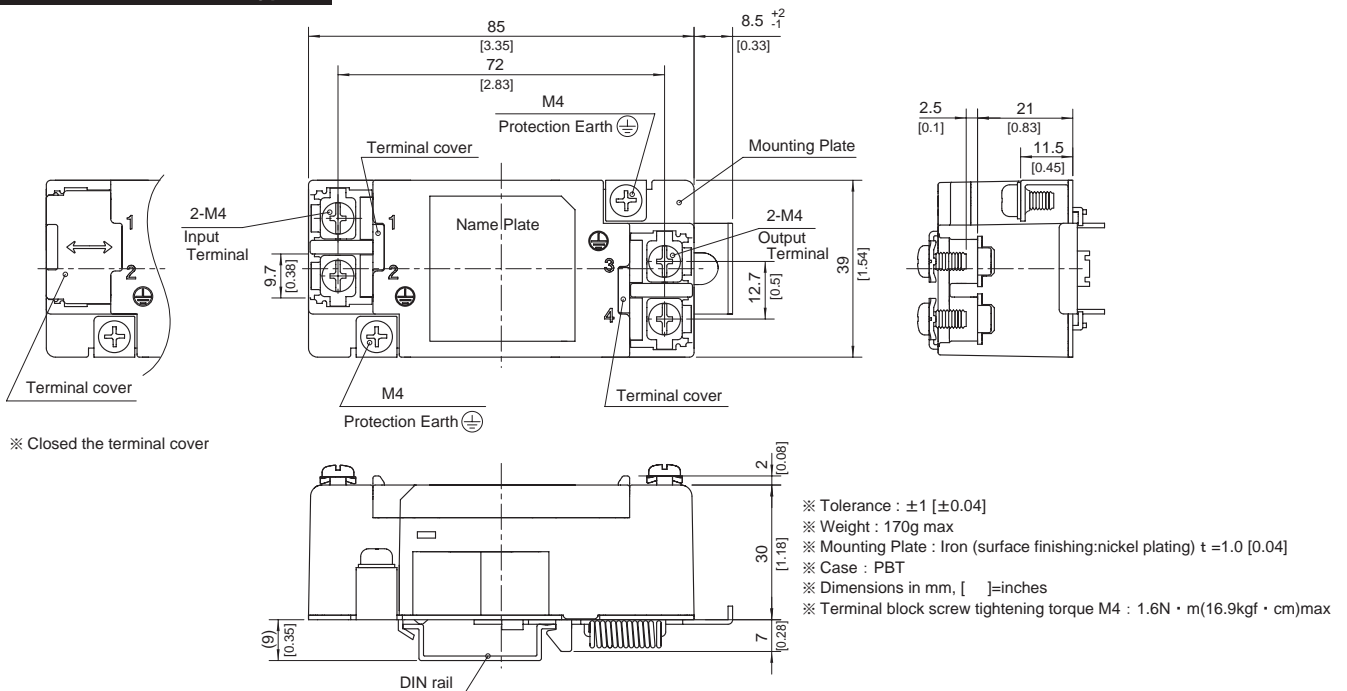

### ■Note when installing the EMI/EMC Filter on a DIN rail.

When the EMI/EMC Filter is grounded through the DIN rail, the proper noise attenuation may not be achieved.

Be sure to connect the protection earth (PE) of the EMI/EMC Filter body to the earth.

