



CHEQUERS ELECTRONIC (CHINA) LIMITED

捷嘉電子(中國)有限公司

APPROVAL SHEET

Manufacturer: Chequers Electronic (China) Limited		Customer:	
Part no.	TEG4P974A1E-32K7680	Customer part no.	-
Part name	Quartz crystal unit	Spec. no.	-
Total page (Includes this page)	7	Issued date	5 th November 2021

This product is compliant to:



RoHS
Directive 2015/863/EU



REACH (219 SVHCs)
Regulation (EC) No. 1907/2006

For customer use

Approved by

For internal use only

Prepared by	Checked by	Approved by
 5-Nov-21 Wong	 5-Nov-21 Frankie	 5-Nov-21 Frankie

Part no. :	TEG4P974A1E-32K7680	Address :	Room 1101-3, Mongkok Commercial Centre, 16 Argyle St., Mongkok, Kowloon, Hong Kong SAR, China
Printed on :	14-Jan-22	Phone :	(852) 2391-6725, (852) 2391-7306, (852) 2391-6158
Prepared by :	Frankie	Fax :	(852) 2789-3205, (852) 2789-3349
Ver. Ctrl. :	110521/F	Homepage :	http://www.chequers-electronic.com
Page(s) :	7	E-mail :	info@chequers-electronic.com



CHEQUERS ELECTRONIC (CHINA) LIMITED
捷嘉電子(中國)有限公司

**Quartz Crystal Unit
Specification**

Part No.: TEG4P974A1E-32K7680

<This product is RoHS and REACH compliant>

Part no.	: TEG4P974A1E-32K7680	Address	: Room 1101-3, Mongkok Commercial Centre, 16 Argyle St., Mongkok, Kowloon, Hong Kong SAR, China
Printed on	: 14-Jan-22	Phone	: (852) 2391-6725, (852) 2391-7306, (852) 2391-6158
Prepared by	: Frankie	Fax	: (852) 2789-3205, (852) 2789-3349
Ver. Ctrl.	: 110521/F	Homepage	: http://www.chequers-electronic.com
Page(s)	: 1 of 5	E-mail	: info@chequers-electronic.com

1. Scope

This specification shall cover the characteristics of the quartz crystal unit

2. Specification no.: -

3. Part no.: TEG4P974A1E-32K7680

4. Electrical specification

4-1	Nominal frequency (Fo)	32.768 KHz
4-2	Holder Type	M5
4-3	Tolerance (25°C)	±20ppm
4-4	Parabolic coefficient	-0.034±0.006ppm/°C ² typical
4-5	Drive level	1.0μW max.
4-6	Loading capacitance	7±0.2pF
	Shunt capacitance	0.9pF typical
	Motional capacitance	3.7fF typical
4-7	Equivalent Series resistance	70KΩ max.
4-8	Insulation resistance	500MΩ min. (D.C. 100V)
4-9	Turnover temperature	25±5°C
4-10	Aging (25°C)	±3ppm / year max.
4-11	Operating temperature range	-40°C to +85°C
4-12	Storage temperature range	-55°C to +125°C

5. Dimension and soldering pattern

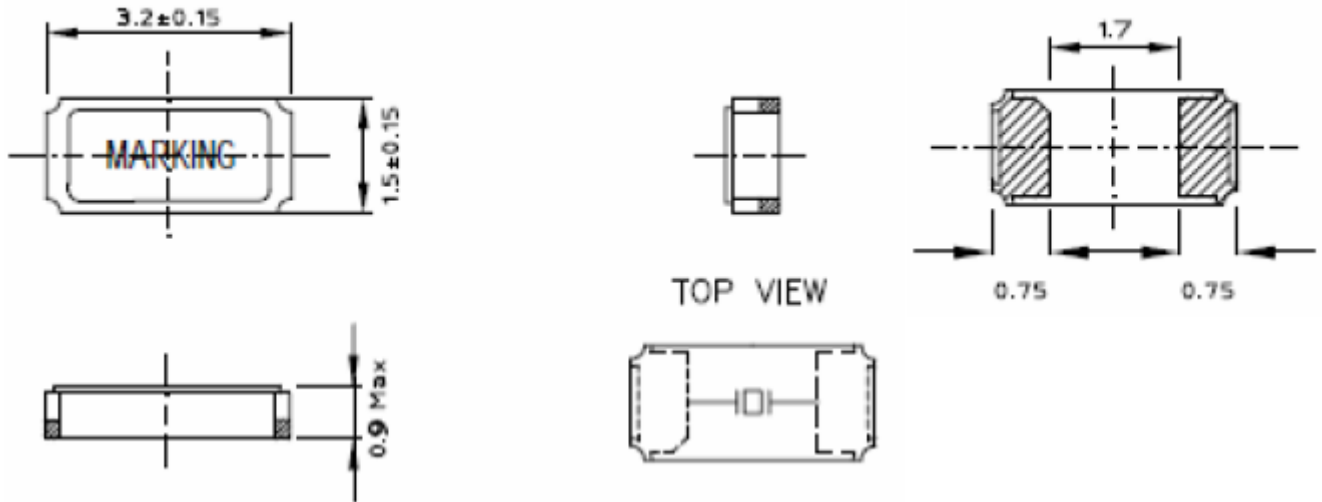

Unit: mm

LAND PATTERN (REFERENCE)

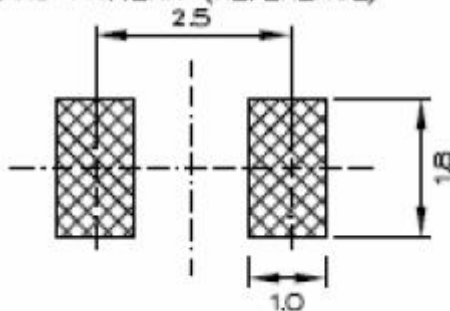

Part no.	:	TEG4P974A1E-32K7680
Printed on	:	14-Jan-22
Prepared by	:	Frankie
Ver. Ctrl.	:	110521/F
Page(s)	:	2 of 5

6. Physical and environmental characteristics

Item	Conditions	Requirements															
Tensile Strength Termination	The unit's lead wire should withstand a tensile force applied to the termination in the direction of its draw-out axis of up to 1000g maintained as is for 10±2s	There should be no abnormalities detected on the unit															
Solderability	The lead is immersed in a 260±5°C solder bath within 2±0.5 seconds.	A new uniform coating of solder shall cover minimum 95% of the surface being immersed.															
Vibration	Endurance condition by a frequency sweep shall be made. The entire frequency range from 10HZ to 60HZ and return to 10HZ, shall be transversed in 1min. Amplitude(total excursion):1.5mm this motion shall be applied for a period of 2h each of 3 mutually perpendicular axes(a total of 6h)	(1) Frequency Change:±5ppm (2) Resistance:±15%															
Drop	Form 100cm height 3 times on 3cm hard wooden floor	(1) Frequency Change:±5ppm (2) Resistance:±15%															
Shock	Peak acceleration:981m/s ² duration of the pulse :6ms three successive shocks shall be applied in both direction of 3 mutually perpendicular axes(a total of 18 shocks)	(1) Frequency Change:±5ppm (2) Resistance:±15%															
Damp heat	The unit shall be stored at a temperature of 40±2°C with relative humidity of 90%to95% for 48h, then it shall be subjected to standard atmospheric conditions for 1~2h after which measurement shall be made.	(1) Frequency Change:±5ppm (2) Resistance:±15%															
Dry heat	The unit shall be stored at a temperature of 100±5°C for 24h, then it shall be subjected to standard atmospheric conditions for 1~2h after which measurement shall be made.	(1) Frequency Change:±5ppm (2) Resistance:±15%															
Low temperature	The unit shall be stored at a temperature of -40±5°C for 48h, then it shall be subjected to standard atmospheric conditions for 1~2h after which measurement shall be made.	(1) Frequency Change:±5ppm (2) Resistance:±15%															
Aging	The unit shall be stored at a temperature of 85±5°C for 7d then it shall be subjected to standard atmospheric conditions for 1~2h after which measurement shall be made.	Refer to specifications															
Temperature cycling	The unit shall be subjected to 5 successive change of temperature cycles, each as show in table below, then it shall be subjected to standard atmospheric conditions for 1~2h after which measurement shall be made <table border="1" data-bbox="402 1330 1067 1480"> <thead> <tr> <th></th> <th>Temperature</th> <th>Duration</th> </tr> </thead> <tbody> <tr> <td>1</td> <td>-40±3°C</td> <td>30 minutes</td> </tr> <tr> <td>2</td> <td>Standard atmospheric pressure</td> <td>30 seconds max.</td> </tr> <tr> <td>3</td> <td>100±3°C</td> <td>30 minutes</td> </tr> <tr> <td>4</td> <td>Standard atmospheric pressure</td> <td>30 seconds max.</td> </tr> </tbody> </table>		Temperature	Duration	1	-40±3°C	30 minutes	2	Standard atmospheric pressure	30 seconds max.	3	100±3°C	30 minutes	4	Standard atmospheric pressure	30 seconds max.	(1) Frequency Change:±5ppm (2) Resistance:±15%
	Temperature	Duration															
1	-40±3°C	30 minutes															
2	Standard atmospheric pressure	30 seconds max.															
3	100±3°C	30 minutes															
4	Standard atmospheric pressure	30 seconds max.															
Sealing	The crystal filter unit shall be immersed in a industry alcohol for 5±0.5 minutes then 25±3°C 1~2 Hr before testing Insulation Resistance>500MΩ	Insulation resistance > 500MΩ															
Resistance to soldering heat	Please refer to reflow soldering profile	Refer to specifications															

Part no.	:	TEG4P974A1E-32K7680
Printed on	:	14-Jan-22
Prepared by	:	Frankie
Ver. Ctrl.	:	110521/F
Page	:	3 of 5

7. Reflow soldering profile

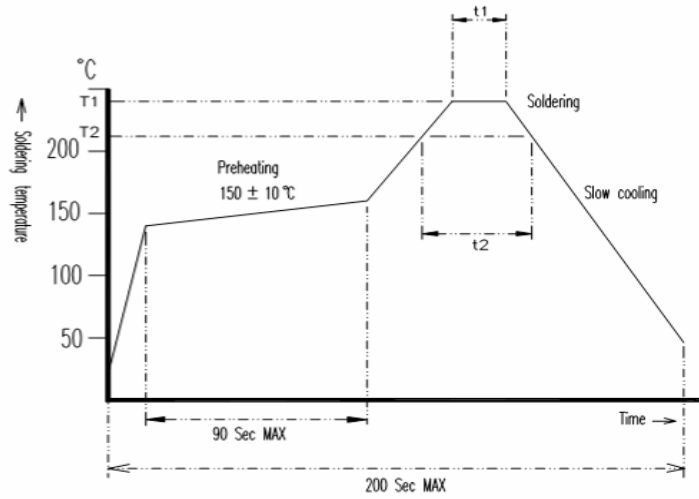

Application\Temperature	Time	T1 / t1	T2 / t2
Lead Free		260±5°C / 10 Sec Max	225Min / 60 Sec Max

8. Packing information

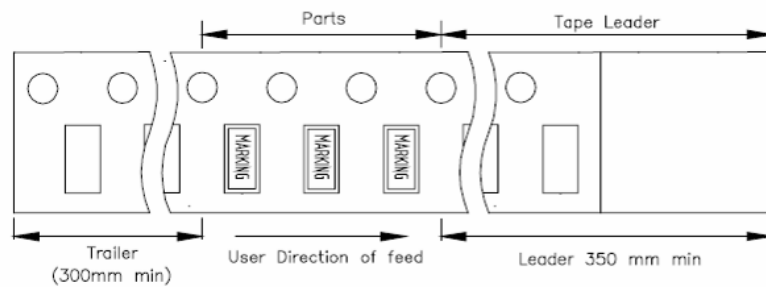
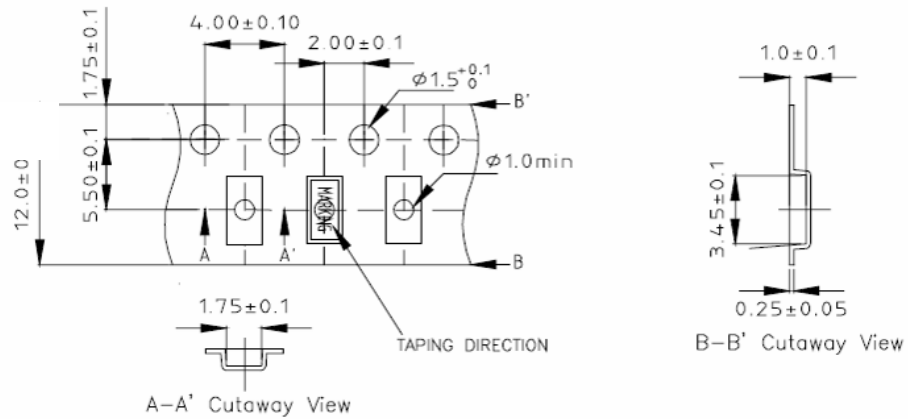

3000 pieces / reel

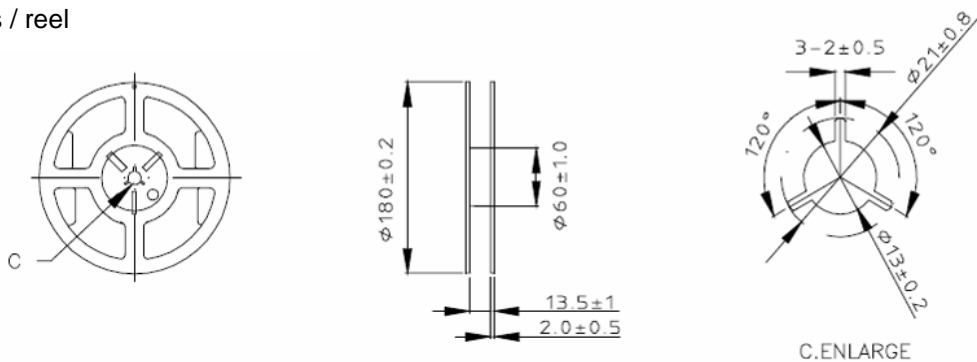

Part no.	: TEG4P974A1E-32K7680
Printed on	: 14-Jan-22
Prepared by	: Frankie
Ver. Ctrl.	: 110521/F
Page	: 4 of 5

9. Notes

9-1 Please contact our sales representatives or engineers before using the products specified in this specification sheet for the following equipment, which require high reliability, and if such equipment fails, which might damage to a third party's life, body or property.

- | | |
|--|--|
| (i) Aerospace equipment | (ii) Medical equipment |
| (iii) Power plant equipment | (iv) Transportation equipment |
| (v) Traffic control equipment | (vi) Disaster control / prevention equipment |
| (vii) Undersea navigational equipment | (viii) Data-processing equipment |
| (ix) or equipment that requires similar complexity and / or reliability of above equipment | |

9-2 Product specifications in this specification sheet are as of the date that is printed on. They are subject to change or discontinue without prior notice. Please check with our sales representative or engineers for details.

9-3 When using our products, please do not exceed the requirements and conditions specified in this specification sheet.

9-4 Should there be any doubt when using our products, please consult our sales representative or engineers before using our products.

Part no.	:	TEG4P974A1E-32K7680
Printed on	:	14-Jan-22
Prepared by	:	Frankie
Ver. Ctrl.	:	110521/F
Page	:	5 of 5