

CentralTM Semiconductor Corp.

145 Adams Ave., Hauppauge, NY 11788 USA
Phone (631) 435-1110 FAX (631) 435-1824

Manufacturers of World Class Discrete Semiconductors
www.centrasemi.com

MJE13005

NPN SILICON
POWER TRANSISTOR

JEDEC TO-220 CASE

DESCRIPTION

The CENTRAL SEMICONDUCTOR MJE13005 is a Silicon NPN Power Transistor, designed for high speed power switching applications.

MAXIMUM RATINGS ($T_C=25^\circ\text{C}$ unless otherwise noted)

	<u>SYMBOL</u>		<u>UNITS</u>
Collector-Emitter Voltage	V_{CEO}	400	V
Collector-Emitter Voltage	V_{CEV}	700	V
Emitter-Base Voltage	V_{EBO}	9.0	V
Collector Current	I_C	4.0	A
Peak Collector Current	I_{CM}	8.0	A
Base Current	I_B	2.0	A
Peak Base Current	I_{BM}	4.0	A
Emitter Current	I_E	6.0	A
Peak Emitter Current	I_{EM}	12	A
Power Dissipation ($T_A=25^\circ\text{C}$)	P_D	2.0	W
Power Dissipation	P_D	75	W
Operating and Storage Junction Temperature	T_J, T_{stg}	-65 to +150	$^\circ\text{C}$
Thermal Resistance	Θ_{JA}	62.5	$^\circ\text{C}/\text{W}$
Thermal Resistance	Θ_{JC}	1.67	$^\circ\text{C}/\text{W}$

ELECTRICAL CHARACTERISTICS ($T_C=25^\circ\text{C}$ unless otherwise noted)

<u>SYMBOL</u>	<u>TEST CONDITIONS</u>	<u>MIN</u>	<u>MAX</u>	<u>UNITS</u>
I_{CEV}	$V_{CE}=700\text{V}, V_{BE(OFF)}=1.5\text{V}$		1.0	mA
I_{CEV}	$V_{CE}=700\text{V}, V_{BE(OFF)}=1.5\text{V}, T_C=100^\circ\text{C}$		5.0	mA
I_{EBO}	$V_{EB}=9.0\text{V}$		1.0	mA
BV_{CEO}	$I_C=10\text{mA}$	400		V
$V_{CE(SAT)}$	$I_C=1.0\text{A}, I_B=0.2\text{A}$		0.5	V
$V_{CE(SAT)}$	$I_C=2.0\text{A}, I_B=0.5\text{A}$		0.6	V
$V_{CE(SAT)}$	$I_C=4.0\text{A}, I_B=1.0\text{A}$		1.0	V
$V_{BE(SAT)}$	$I_C=1.0\text{A}, I_B=0.2\text{A}$		1.2	V
$V_{BE(SAT)}$	$I_C=2.0\text{A}, I_B=0.5\text{A}$		1.6	V
h_{FE}	$V_{CE}=5.0\text{V}, I_C=1.0\text{A}$	10	60	
h_{FE}	$V_{CE}=5.0\text{V}, I_C=2.0\text{A}$	8.0	40	

(Continued)

ELECTRICAL CHARACTERISTICS (CONTINUED)

<u>SYMBOL</u>	<u>TEST CONDITIONS</u>	<u>MIN</u>	<u>TYP</u>	<u>MAX</u>	<u>UNITS</u>
f_T	$V_{CE}=10V, I_C=500mA, f=1.0MHz$	4.0			MHz
C_{ob}	$V_{CB}=10V, I_E=0, f=100kHz$		130		pF
<u>Resistive Load</u>					
t_d	$V_{CC}=125V, I_C=2.0A, I_{B1}=I_{B2}=0.4A$			0.1	μs
t_r	$t_p=25\mu s, \text{Duty Cycle} \leq 1.0\%$			0.7	μs
t_s				4.0	μs
t_f				0.9	μs
<u>Inductive Load</u>					
t_{sv}	$I_C=2.0A, V_{clamp}=300V, I_{B1}=0.4A,$			4.0	μs
t_c	$V_{BE(off)}=5.0V, T_C=100^\circ C$			0.9	μs
t_{fi}			0.16		μs

TO-220 PACKAGE - MECHANICAL OUTLINE

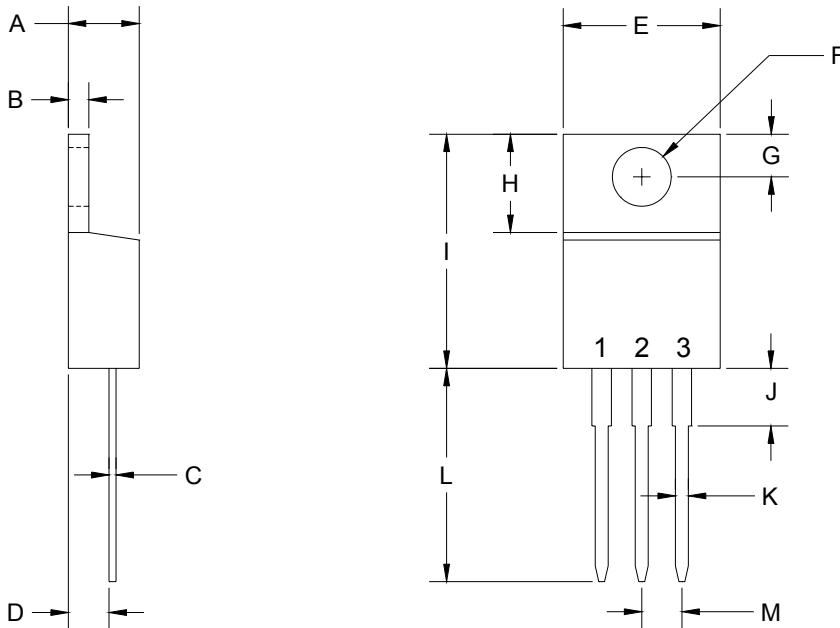

SYMBOL	DIMENSIONS			
	INCHES		MILLIMETERS	
	MIN	MAX	MIN	MAX
A	0.170	0.190	4.31	4.82
B	0.045	0.055	1.15	1.39
C	0.013	0.026	0.33	0.65
D	0.083	0.107	2.10	2.72
E	0.394	0.417	10.01	10.60
F (DIA)	0.140	0.157	3.55	4.00
G	0.100	0.118	2.54	3.00
H	0.230	0.270	5.85	6.85
I	0.560	0.625	14.23	15.87
J	-	0.250	-	6.35
K	0.025	0.038	0.64	0.96
L	0.500	0.579	12.70	14.70
M	0.090	0.110	2.29	2.79

TO-220 (REV: R2)

Lead Code:

R2

- 1) Base
- 2) Collector
- 3) Emitter

Tab is Common to Pin 2

CentralTM
Semiconductor Corp.

145 Adams Ave., Hauppauge, NY 11788 USA
Phone (631) 435-1110 FAX (631) 435-1824

Manufacturers of World Class Discrete Semiconductors
www.centralsemi.com

Mouser Electronics

Related Product Links

[610-MJE13005 - Central Semiconductor MJE13005](#)