

# HEDR-5xxx High Resolution Series

## Three Channel Quick Assembly Encoders



### Data Sheet



#### Description

The Avago HEDR-5xxx series encoders are higher resolution replacements for our existing low cost HEDS-5xxx series three channel optical encoders. These upgraded encoders now come with resolution of 1200 cycles per revolution (CPR) to 3600 CPR and are designed for easy assembly. The base-plate and outer diameter of these encoders are also compatible with the legacy HEDS-5xxx series, making them ideal replacements for users who wish to upgrade due to higher CPR requirements.

Each encoder contains a codewheel, LED source, detector and integrated circuitry. As the codewheel rotates, the detector IC generates two square waves in quadrature and an index pulse (high state) of 90°e (gated to signal A and B low), once per each full rotation of the codewheel.

The HEDR-5xxx encoders accommodate shaft diameters of 2 mm to 8 mm and can operate in high temperature environments of up to 100 °C.

#### Features

- Three channel encoder A,B and I
- Available with ribbon cabling
- Single 5 V supply
- Resolution of 1200 to 3600 CPR
- Available in TTL compatible and line driver options
- Quick assembly
- IP40 rating
- No signal adjustment required
- Compact size: 35 mm (L) × 30 mm (W) × 20 mm (H)
- -40 °C to 100 °C or -20 °C to 85 °C operating temperature option

#### Applications

High volume applications such as industrial printers, plotters, tape drives, positioning tables ,and automatic handlers

Note: Avago Technologies encoders are not recommended for use in safety critical applications, e.g., ABS braking systems, power steering, life support systems and critical care medical equipment. Avago's products and software are not specifically designed, manufactured or authorized for sale as parts, components or assemblies for the planning, construction, maintenance or direct operation of a nuclear facility or for use in medical devices or applications. Customers are solely responsible, and waive all rights to make claims against Avago or its suppliers, for all losses, damage, expense or liability in connection with such use. Please contact your local sales representative if more clarification is needed.

## Package Dimensions

HEDR-5xxx Extension series are available with ribbon cabling:

### Ribbon Cable

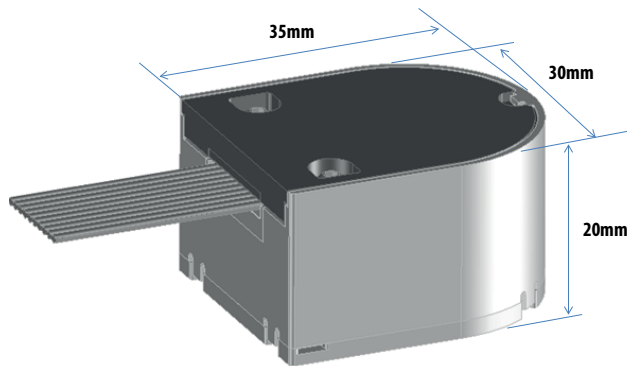

**Standard**

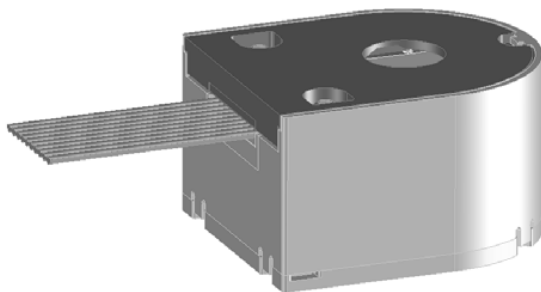

**Through hole**

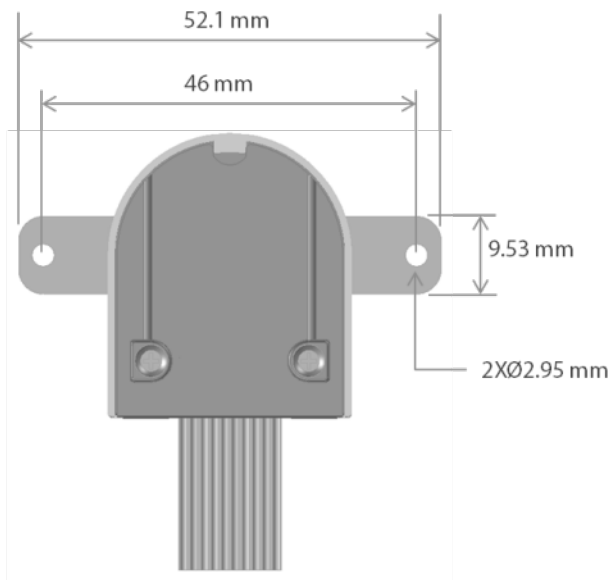

**With external ear option**

## Mounting Considerations

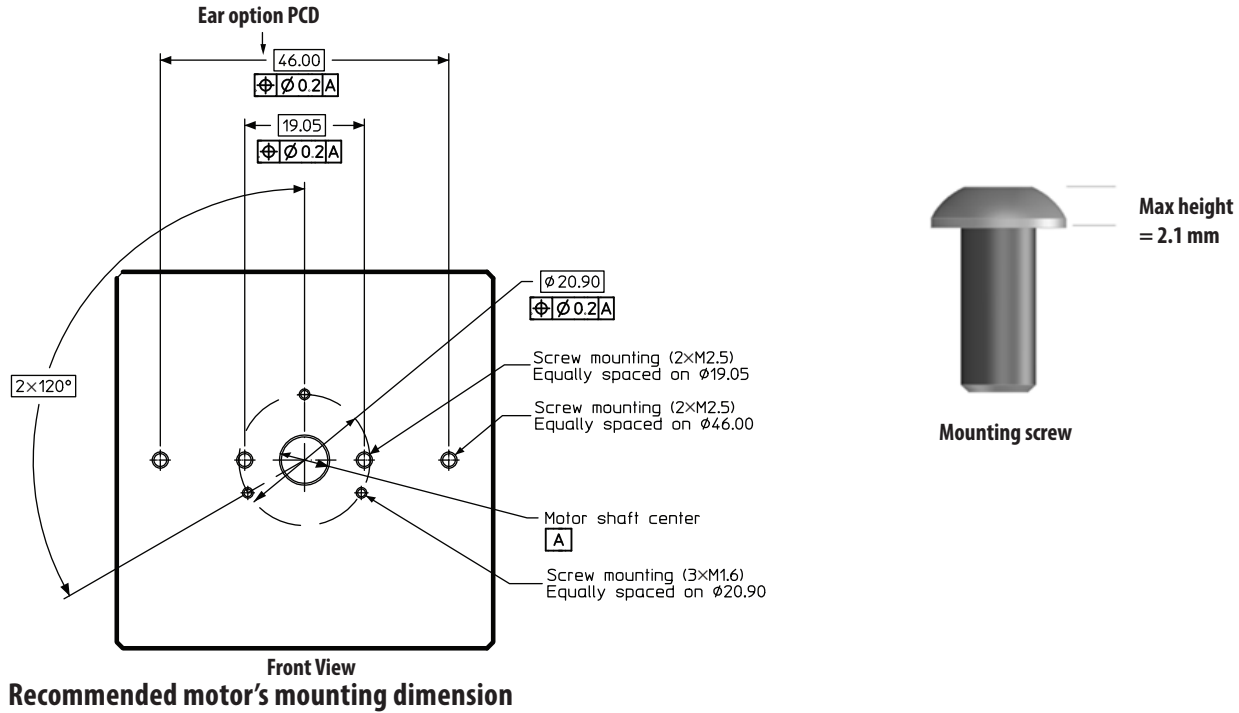

## Easy mounting and installation

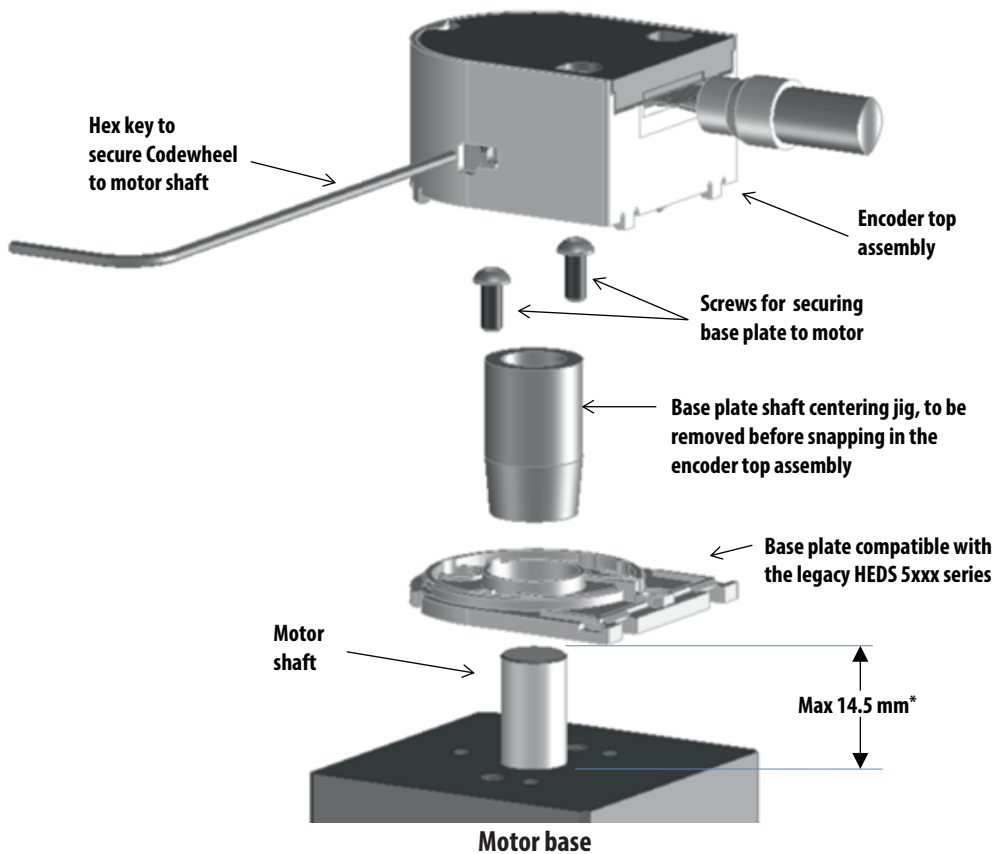

\* - Not applicable for 2048 cpr option. For 2048 cpr option, the recommend range is 11.5 to 13.5 mm.

It is recommended that adhesives (Heron - Tuffbond™ 317) be applied to the screw-base plate interface to prevent screw loosening due to CTE effect between screw and plastic at operating temperature..

## Absolute Maximum Rating

Parameter	Value	Units	Notes
Storage Temperature, $T_S$	-40 to 100 -20 to 85	°C	High temperature option Low temperature option
Operating Temperature, $T_A$	-40 to 100 -20 to 85	°C	High temperature option Low temperature option
Supply Voltage, $V_{CC}$	-0.5 to 7	V	
Output Current per Channel, $I_{OUT}$			
Voltage	5	mA	
Line Driver	20	mA	
Vibration	10G, 55 to 1000	Hz	
Shaft Axial Play	±0.175	mm	
Shaft TIR (max.)	0.05	mm	

## Output waveform

**Direction of Rotation:** When the encoder rotates in the counter-clockwise direction (as viewed from the top of the encoder), channel A will lead channel B. If it rotates in the clockwise direction, channel B will lead channel A.

**Index Pulse Width ( $P_0$ ):** The number of electrical degrees that an index output is high during one full shaft rotation. This value is nominally 90°e (1/4 cycle) gated to signals A and B, both at low state.

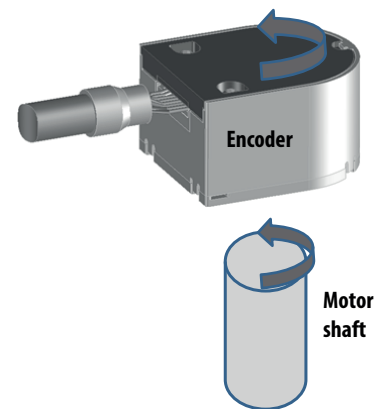
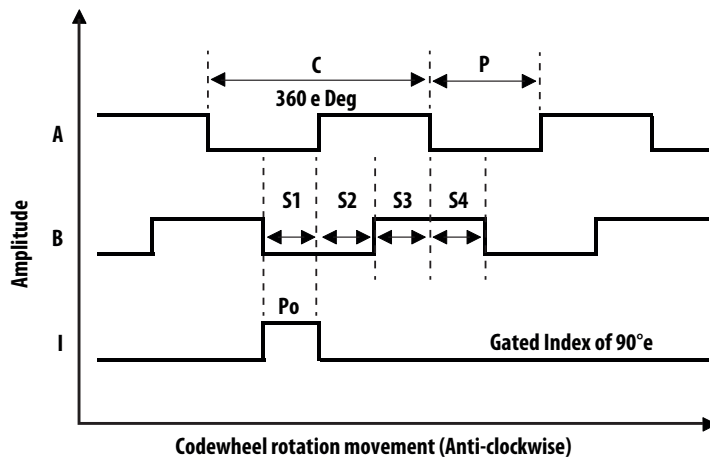

## Recommended Operating Conditions

Parameter	Symbol	Min.	Typ.	Max.	Units	Notes
Temperature	$T_A$	-40 -20		100 85	°C	High temperature option Low temperature option
Supply Voltage	$V_{CC}$	4.5	5.0	5.5	V	Ripple < 100 mV <sub>p-p</sub>
Current Consumption			38		mA	No load
Count Frequency <sup>[1]</sup>	$f$			320 <sup>[2]</sup>	kHz	Velocity (rpm) x N/60

Notes:

1. Applicable for line driver output.
2. Valid for 2400 CPR and above.

## Encoding Characteristics

Encoding characteristics over recommended operating range and recommended mounting tolerances, unless otherwise specified.

Part No.	Description	Symbol	Typ.	Max.	Notes
HEDR-5xxx (Three Channel)	Pulse Width	P		P ± P/4	
	Logic State Width	S		S ± S/2	
	Index Pulse Width	P <sub>o</sub>	90°		
Voltage Output					
Rise time		t <sub>r</sub>		1 μs	
Fall time		t <sub>f</sub>			
Line Driver					
Rise time		t <sub>r</sub>	200 ns		
Fall time		t <sub>f</sub>			

## Mechanical Characteristics

Parameter	Symbol	Dimension	Tolerance	Units
Blind Hollow Shaft diameter		Refer to ordering information	g6	mm
Shaft Length		11.5 to 14.5*		mm
Height		20	± 0.5	mm
Width		30	± 0.5	mm
Length		35	± 0.5	mm
Hub Set Screw		M3		

\* - Not applicable for 2048 cpr option. For 2048 cpr option, the recommend range is 11.5 to 13.5 mm.

## Ribbon cable

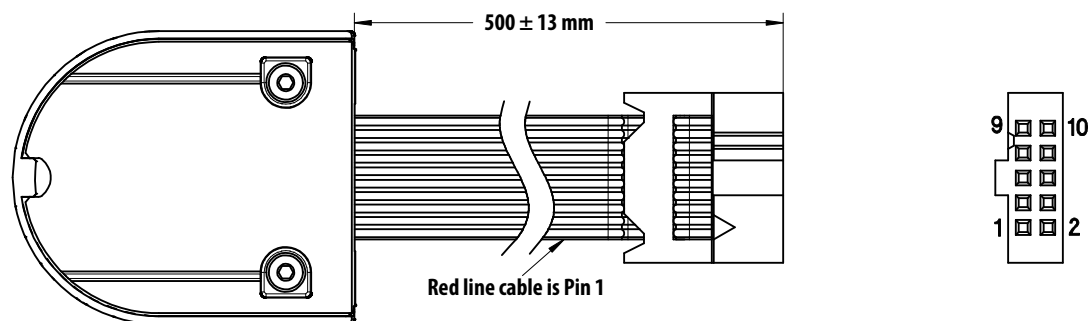

### Line Driver option

Pin No.	Pin Assignment
1	NC
2	VCC
3	GND
4	NC
5	A -
6	A +
7	B -
8	B +
9	I -
10	I +

### Single-ended option

Pin No.	Pin Assignment
1	NC
2	VCC
3	GND
4	NC
5	NC
6	A +
7	NC
8	B +
9	NC
10	I +

## Ordering Information

Available options for HEDR-5xxx-xxxx

HEDR-5	x	x	x	—	xx	x	x
	Mounting Type	Output Type	Output Wire Cabling Type		CPR	Temperature Rating/ Index Gating	Shaft Diameter
	5 – Standard	E – Voltage (TTL)	2 – Ribbon		B2 – 1200	0 – High / 90°	0 – 2 mm
	6 – External Ears	L – Line Driver			B4 – 1250	1 – High / 180°	1 – 3 mm
	7 – Standard Through Hole				B8 – 1500	L – Std / 90°	3 – 5/32"
	8 – External Ears Through Hole				BB – 1800	M – Std / 180°	4 – 3/16"
					BH – 2048	Note:	5 – 1/4"
					BL – 2400	High → -40 to 100 °C	6 – 4 mm
					BP – 2500	Std → -20 to 85 °C	7 – 5 mm
					BS – 2880		8 – 6 mm
					BV – 3000		9 – 8 mm
					BY – 3600		

## Currently available options

	High temperature		Standard temperature
1.	HEDR-55L2-BH07	11.	HEDR-55L2-BHL7
2.	HEDR-55L2-BH09	12.	HEDR-55L2-BHL9
3.	HEDR-55L2-BL07	13.	HEDR-55L2-BPL7
4.	HEDR-55L2-BL09	14.	HEDR-55L2-BPL9
5.	HEDR-55L2-BV07	15.	HEDR-55L2-BYL8
6.	HEDR-55L2-BV09		
7.	HEDR-55L2-BY07		
8.	HEDR-55L2-BY09		
9.	HEDR-55L2-BP07		
10.	HEDR-55L2-BP09		

Note: For other options, please refer to factory.

For product information and a complete list of distributors, please go to our web site: [www.avagotech.com](http://www.avagotech.com)

Avago, Avago Technologies, and the A logo are trademarks of Avago Technologies in the United States and other countries. Data subject to change. Copyright © 2005-2013 Avago Technologies. All rights reserved. AV02-3823EN - December 16, 2013

