

HCTL-2000, HCTL-2016, HCTL-2020

Quadrature Decoder/Counter Interface ICs



Data Sheet

Description

The HCTL-2000, 2016, 2020 are CMOS ICs that perform the quadrature decoder, counter, and bus interface function. The HCTL-20XX family is designed to improve system performance in digital closed loop motion control systems and digital data input systems. It does this by shifting time intensive quadrature decoder functions to a cost effective hardware solution. The entire HCTL-20XX family consists of a 4x quadrature decoder, a binary up/down state counter, and an 8-bit bus interface.

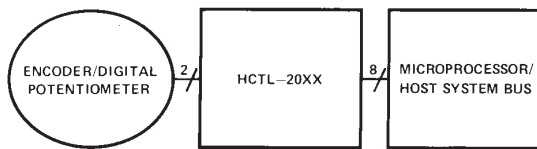

DIGITAL MOTION ENCODING

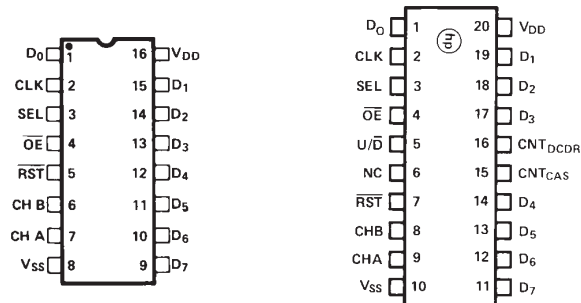

PINOUT A

PINOUT B

Features

- Interfaces encoder to microprocessor
- 14 MHz clock operation
- Full 4X decode
- High noise immunity: Schmitt Trigger inputs digital noise filter
- 12 or 16-bit binary up/down counter
- Latched outputs
- 8-Bit tristate interface
- 8, 12, or 16-bit operating modes
- Quadrature decoder output signals, up/down and count
- Cascade output signals, up/down and count
- Substantially reduced system software

Applications

- Interface quadrature incremental encoders to microprocessors
- Interface digital potentiometers to digital data input buses

Note: Avago Technologies encoders are not recommended for use in safety critical applications. Eg. ABS braking systems, power steering, life support systems and critical care medical equipment. Please contact sales representative if more clarification is needed.

Devices

Part Number	Description	Package Drawing
HCTL-2000	12-bit counter. 14 MHz clock operation.	A
HCTL-2016	All features of the HCTL-2000. 16-bit counter.	A
HCTL-2020	All features of the HCTL-2016. Quadrature decoder output signals. Cascade output signals.	B

ESD WARNING: Standard CMOS handling precautions should be observed with the HCTL-20XX family ICs.

The use of Schmitt-triggered CMOS inputs and input noise filters allows reliable operation in noisy environments. The HCTL-2000 contains a 12-bit counter. The HCTL-2016 and 2020 contain a 16-bit counter. The HCTL-2020 also contains quadrature decoder output signals and cascade signals

for use with many standard counter ICs. The HCTL-20XX family provides LSTTL compatible tristate output buffers. Operation is specified for a temperature range from -40 to +85° C at clock frequencies up to 14 MHz.

Package Dimensions

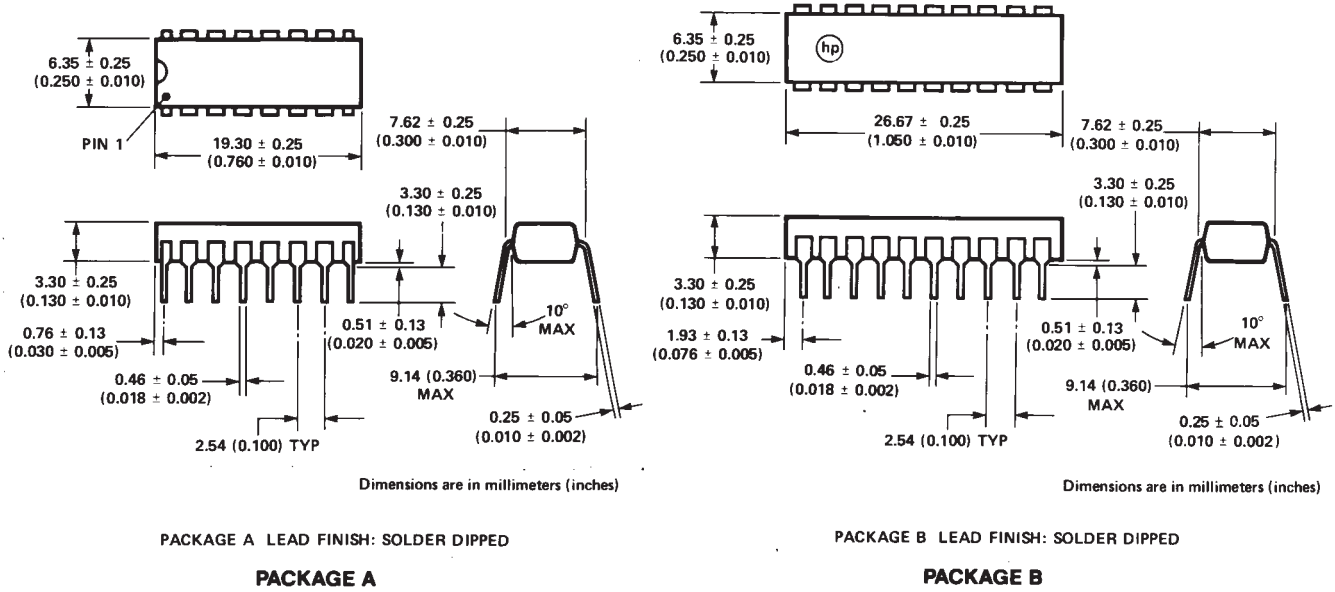

Operating Characteristics

Table 1. Absolute Maximum Ratings

(All voltages below are referenced to V_{SS})

Parameter	Symbol	Limits	Units
DC Supply Voltage	V_{DD}	-0.3 to +5.5	V
Input Voltage	V_{IN}	-0.3 to $V_{DD}+0.3$	V
Storage Temperature	T_S	-40 to +125	°C
Operating Temperature	$T_A^{[1]}$	-40 to +85	°C

Table 2. Recommended Operating Conditions

Parameter	Symbol	Limits	Units
DC Supply Voltage	V_{DD}	+4.5 to +5.5	V
Ambient Temperature	$T_A^{[1]}$	-40 to +85	°C

Table 3. DC Characteristics $V_{DD} = 5 V \pm 5\%$; $T_A = -40$ to $85^\circ C$

Parameter	Symbol	Condition	Min.	Typ.	Max.	Unit
Low-Level Input Voltage	$V_{IL}^{[2]}$				1.5	V
High-Level Input Voltage	$V_{IH}^{[2]}$		3.5			V
Schmitt-Trigger Positive-Going Threshold	V_{T+}			3.5	4.0	V
Schmitt-Trigger Negative-Going Threshold	V_{T-}		1.0	1.5		V
Schmitt-Trigger Hysteresis	V_H		1.0	2.0		V
Input Current	I_{IN}	$V_{IN} = V_{SS}$ or V_{DD}	-10	1	+10	μA
High-Level Output Voltage	$V_{OH}^{[2]}$	$I_{OH} = 1.6$ mA	2.4	4.5		V
Low-Level Output Voltage	$V_{OL}^{[2]}$	$I_{OL} = +4.8$ mA		0.2	0.4	V
High-Z Output Leakage Current	I_{OZ}	$V_O = V_{SS}$ or V_{DD}	-10	1	+10	μA
Quiescent Supply Current	I_{DD}	$V_{IN} = V_{SS}$ or V_{DD} , $V_O = HiZ$		1	5	μA
Input Capacitance	C_{IN}	Any Input ^[3]		5		pF
Output Capacitance	C_{OUT}	Any Output ^[3]		6		pF

Notes:

1. Free air.
2. In general, for any V_{DD} between the allowable limits (+4.5 V to +5.5 V), $V_{IL} = 0.3 V_{DD}$ and $V_{IH} = 0.7 V_{DD}$; typical values are $V_{OH} = V_{DD} - 0.5$ V @ $I_{OH} = -40$ μA and $V_{OL} = V_{SS} + 0.2$ V @ $I_{OL} = 1.6$ mA.
3. Including package capacitance.

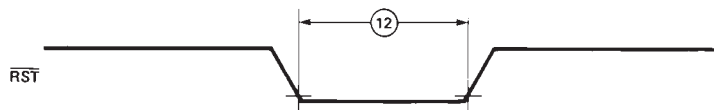

Figure 1. Reset Waveform.

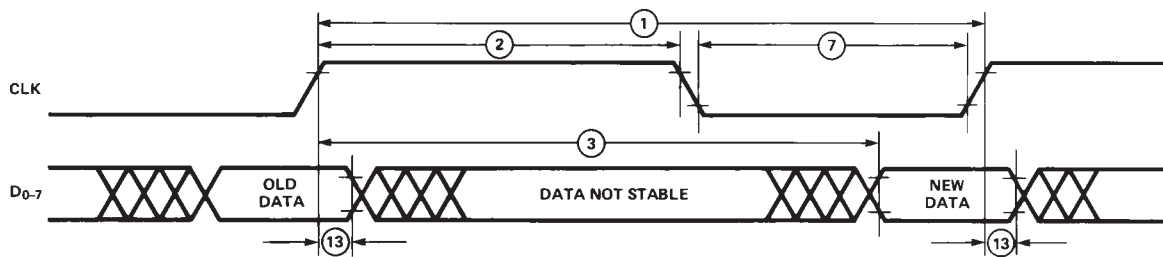

Figure 2. Waveform for Positive Clock Related Delays.

Functional Pin Description

Table 4. Functional Pin Descriptions

Symbol	Pin 2000/2016	Pin 2020	Description						
V _{DD}	16	20	Power Supply						
V _{SS}	8	10	Ground						
CLK	2	2	CLK is a Schmitt-trigger input for the external clock signal.						
CHA CHB	7 6	9 8	CHA and CHB are Schmitt-trigger inputs which accept the outputs from a quadrature encoded source, such as incremental optical shaft encoder. Two channels, A and B, nominally 90 degrees out of phase, are required.						
$\overline{\text{RST}}$	5	7	This active low Schmitt-trigger input clears the internal position counter and the position latch. It also resets the inhibit logic. RST is asynchronous with respect to any other input signals.						
$\overline{\text{OE}}$	4	4	This CMOS active low input enables the tri-state output buffers. The $\overline{\text{OE}}$ and SEL inputs are sampled by the internal inhibit logic on the falling edge of the clock to control the loading of the internal position data latch.						
SEL	3	3	This CMOS input directly controls which data byte from the position latch is enabled into the 8-bit tri-state output buffer. As in $\overline{\text{OE}}$ above, SEL also controls the internal inhibit logic.						
<table border="1"> <thead> <tr> <th>SEL</th> <th>BYTE SELECTED</th> </tr> </thead> <tbody> <tr> <td>0</td> <td>High</td> </tr> <tr> <td>1</td> <td>Low</td> </tr> </tbody> </table>				SEL	BYTE SELECTED	0	High	1	Low
SEL	BYTE SELECTED								
0	High								
1	Low								
CNT _{DCDR}		16	A pulse is presented on this LSTTL-compatible output when the quadrature decoder has detected a state transition.						
U/ $\overline{\text{D}}$		5	This LSTTL-compatible output allows the user to determine whether the IC is counting up or down and is intended to be used with the CNT _{DCDR} and CNT _{CAS} outputs. The proper signal U (high level) or $\overline{\text{D}}$ (low level) will be present before the rising edge of the CNT _{DCDR} and CNT _{CAS} outputs.						
CNT _{CAS}		15	A pulse is presented on this LSTTL-compatible output when the HCTL-2020 internal counter overflows or underflows. The rising edge on this waveform may be used to trigger an external counter.						
D0	1	1	These LSTTL-compatible tri-state outputs form an 8-bit output port through which the contents of the 12/16-bit position latch may be read in 2 sequential bytes. The high byte, containing bits 8-15, is read first (on the HCTL-2000, the most significant 4 bits of this byte are set to 0 internally). The lower byte, bits 0-7, is read second.						
D1	15	19							
D2	14	18							
D3	13	17							
D4	12	14							
D5	11	13							
D6	10	12							
D7	9	11							
NC		6	Not connected – this pin should be left floating.						

Switching Characteristics

Table 5. Switching Characteristics Min/Max specifications at $V_{DD} = 5.0 \pm 5\%$, $T_A = -40$ to $+85^\circ\text{C}$.

Symbol	Description	Min.	Max.	Units
1	t_{CLK}	70		ns
2	t_{CHH}	28		ns
3	$t_{CD}^{[1]}$		65	ns
4	t_{ODE}		65	ns
5	t_{ODZ}		40	ns
6	t_{SDV}		65	ns
7	t_{CLH}	28		ns
8	$t_{SS}^{[2]}$	20		ns
9	$t_{OS}^{[2]}$	20		ns
10	$t_{SH}^{[2]}$	0		ns
11	$t_{OH}^{[2]}$	0		ns
12	t_{RST}	28		ns
13	t_{DCD}	10		ns
14	t_{DSD}	5		ns
15	t_{DOD}	5		ns
16	t_{UDD}		45	ns
17	t_{CHD}		45	ns
18	t_{CLD}		45	ns
19	t_{UDH}	10		ns
20	t_{UDCS}	$t_{CLK}-45$		ns
21	t_{UDCH}	$t_{CLK}-45$		ns

Notes:

1. t_{CD} specification and waveform assume latch not inhibited.
2. t_{SS} , t_{OS} , t_{SH} , t_{OH} only pertain to proper operation of the inhibit logic. In other cases, such as 8 bit read operations, these setup and hold times do not need to be observed.

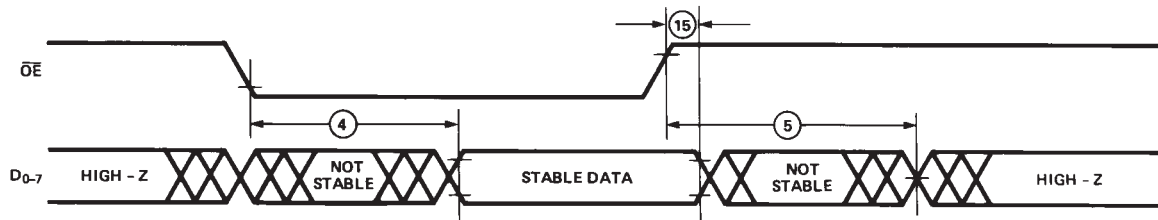

Figure 3. Tri-State Output Timing.

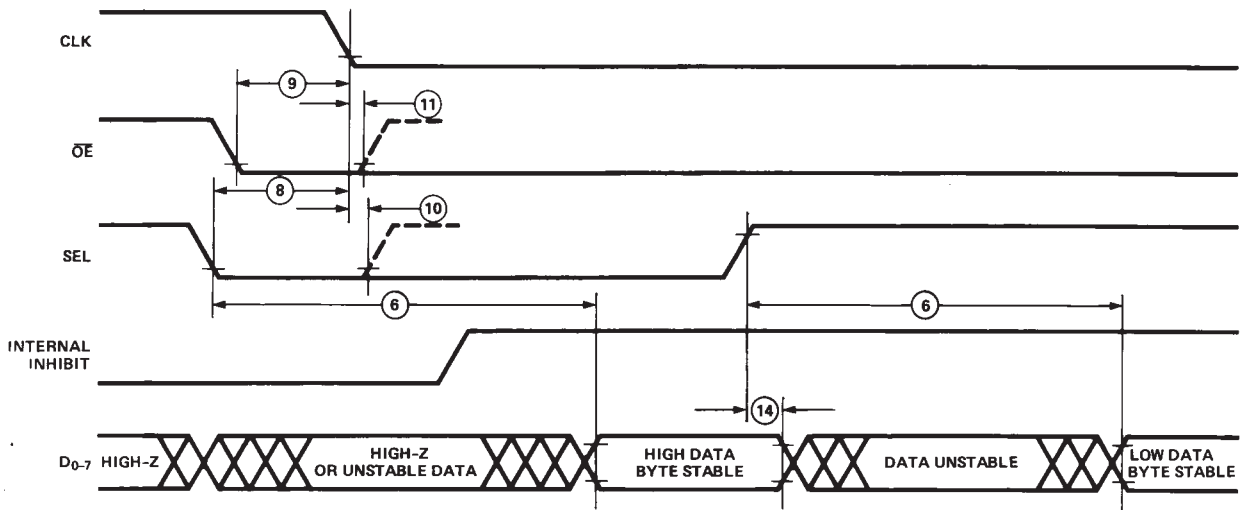

Figure 4. Bus Control Timing.

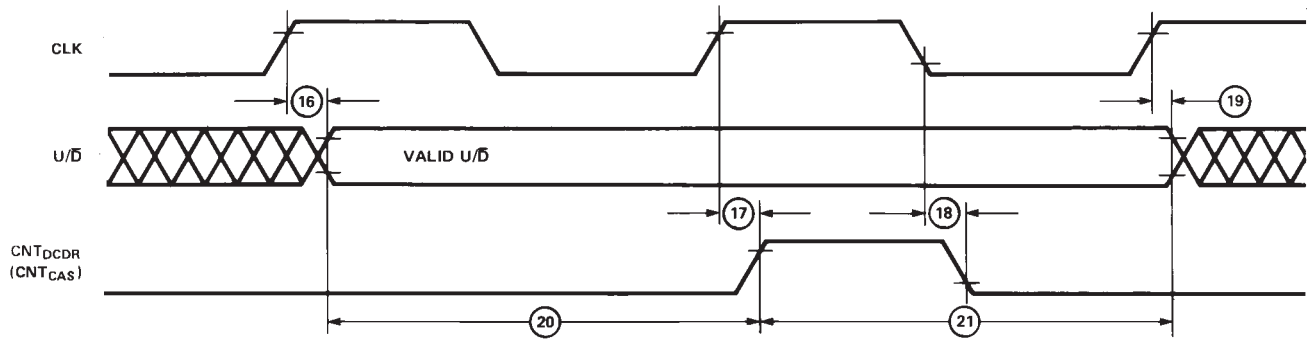

Figure 5. Decoder, Cascade Output Timing (HCTL-2020 only).

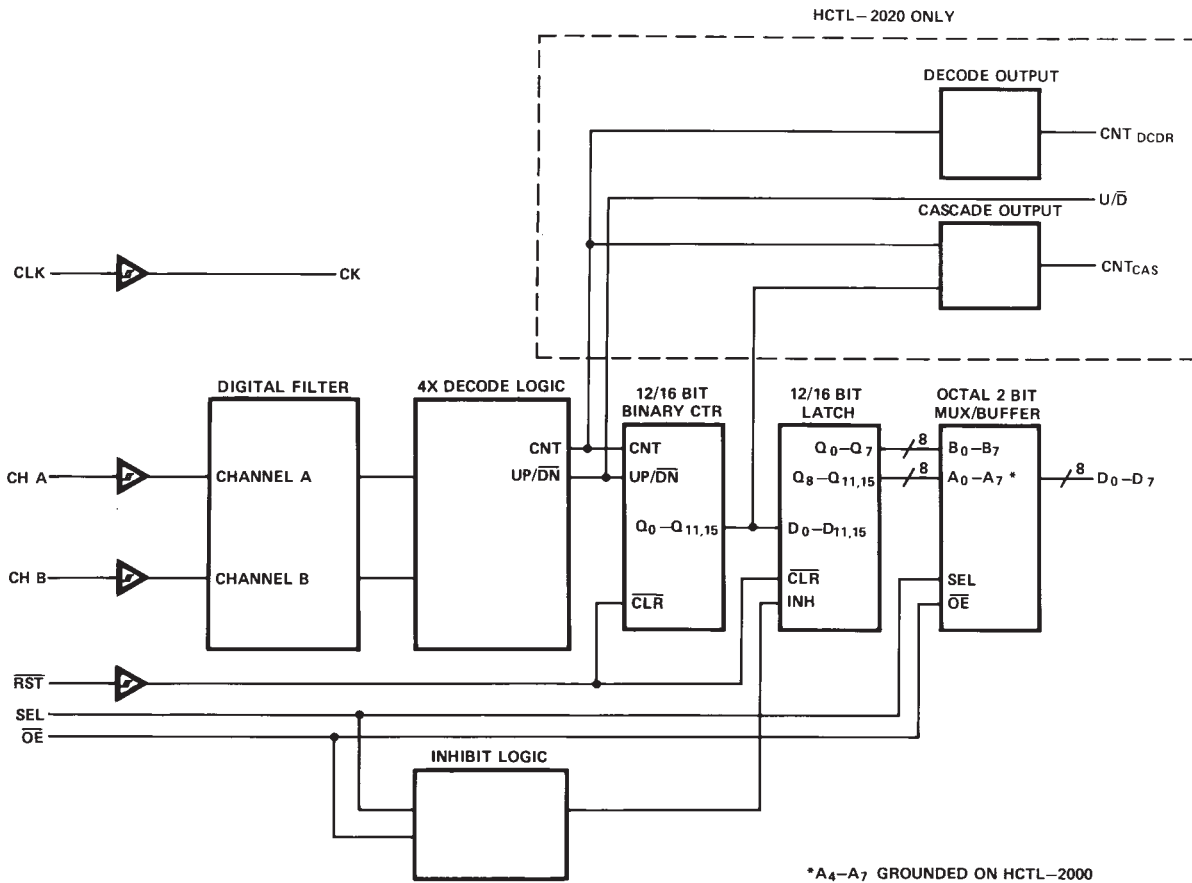

Figure 6. Simplified Logic Diagram.

Operation

A block diagram of the HCTL-20XX family is shown in Figure 6. The operation of each major function is described in the following sections.

Digital Noise Filter

The digital noise filter section is responsible for rejecting noise on the incoming quadrature signals. The input section uses two techniques to implement improved noise rejection. Schmitt-trigger inputs and a three-clock-cycle delay filter combine to reject low level noise and large, short duration noise spikes that typically occur in motor system applications. Both common mode and differential mode noise are rejected. The user benefits from these techniques by improved integrity of the data in the counter. False counts triggered by noise are avoided.

Figure 7 shows the simplified schematic of the input section. The signals are first passed through a Schmitt trigger buffer to address the problem of input signals with slow rise times and low level noise (approximately $< 1\text{ V}$). The cleaned up signals are then passed to a four-bit delay filter. The signals on each channel are sampled on rising clock edges. A time history of the signals is stored in the four-bit shift register. Any change on the input is tested for a stable level being present for three consecutive rising clock edges. Therefore, the filtered output waveforms can change only after an input level has the same value for three consecutive rising clock edges. Refer to Figure 8 which shows the timing diagram. The result of this circuitry is that short noise spikes between rising clock edges are ignored and pulses shorter than two clock periods are rejected.

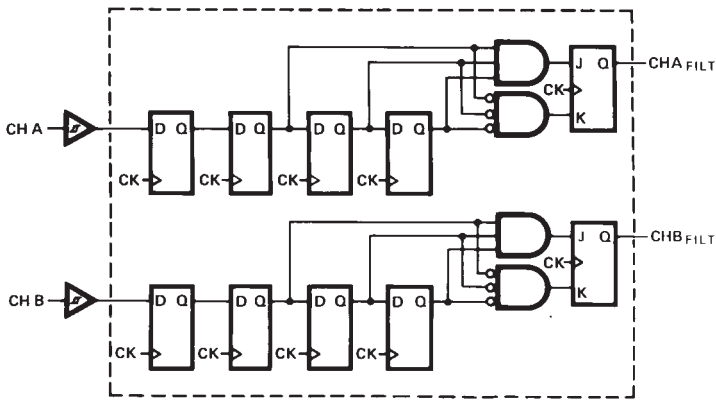

Figure 7. Simplified Digital Noise Filter Logic.

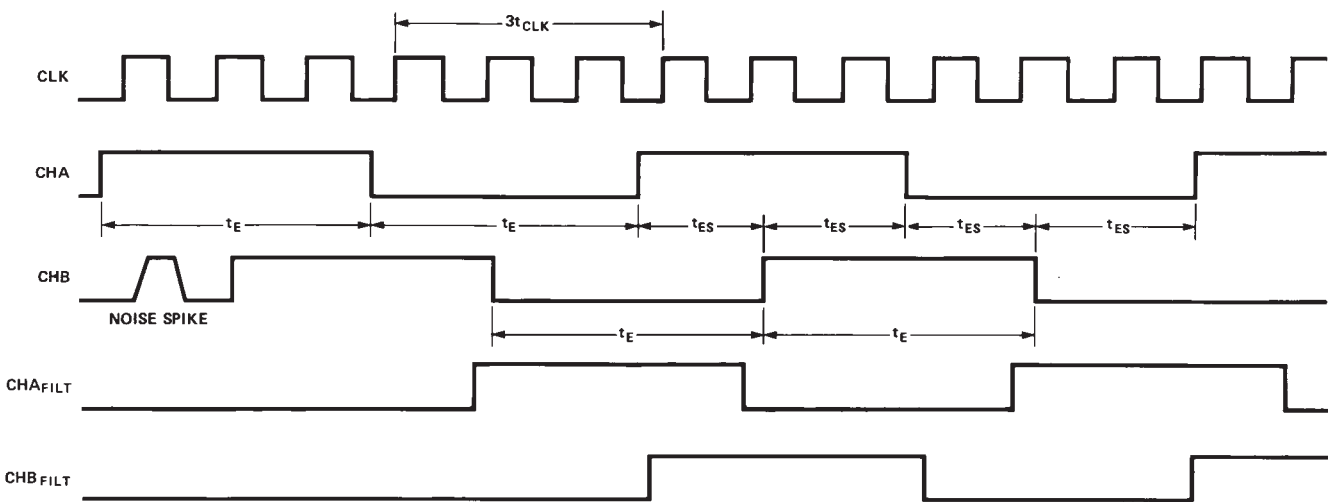

Figure 8. Signal Propagation through Digital Noise Filter.

Quadrature Decoder

The quadrature decoder decodes the incoming filtered signals into count information. This circuitry multiplies the resolution of the input signals by a factor of four (4X decoding). When using an encoder for motion sensing, the user benefits from the increased resolution by being able to provide better system control.

The quadrature decoder samples the outputs of the CHA and CHB filters. Based on the past binary state of the two signals and the present state, it outputs a count signal and a direction signal to the internal position counter. In the case of the HCTL-2020, the signals also go to external pins 5 and 16 respectively.

Figure 9 shows the quadrature states and the valid state transitions. Channel A leading channel B results in counting up. Channel B leading channel A results in counting down. Illegal state transitions, caused by faulty encoders or noise severe enough to pass through the filter, will produce an erroneous count.

Design Considerations

The designer should be aware that the operation of the digital filter places a timing constraint on the relationship between incoming quadrature signals and the external clock. Figure 8 shows the timing waveform with an incremental encoder input. Since an input has to be stable for three rising clock edges, the encoder pulse width (t_E – low or high) has to be greater than three clock periods ($3t_{CLK}$). This guarantees that the asynchronous input will be stable during three consecutive rising clock edges. A realistic design also has to take into account finite rise times of the waveforms, asymmetry of the waveforms, and noise. In the presence of large amounts of noise, t_E should be much greater than $3t_{CLK}$ to allow for the interruption of the consecutive level sampling by the three-bit delay filter. It should be noted that a change on the inputs that is qualified by the filter will internally propagate in a maximum of seven clock periods.

The quadrature decoder circuitry imposes a second timing constraint between the external clock and the input signals. There must be at least one clock period between consecutive quadrature states. As shown in Figure 9, a quadrature state is defined by consecutive edges on both channels. Therefore, t_{ES} (encoder state period) $> t_{CLK}$. The designer must account for deviations from the nominal 90 degree phasing of input signals to guarantee that $t_{ES} > t_{CLK}$.

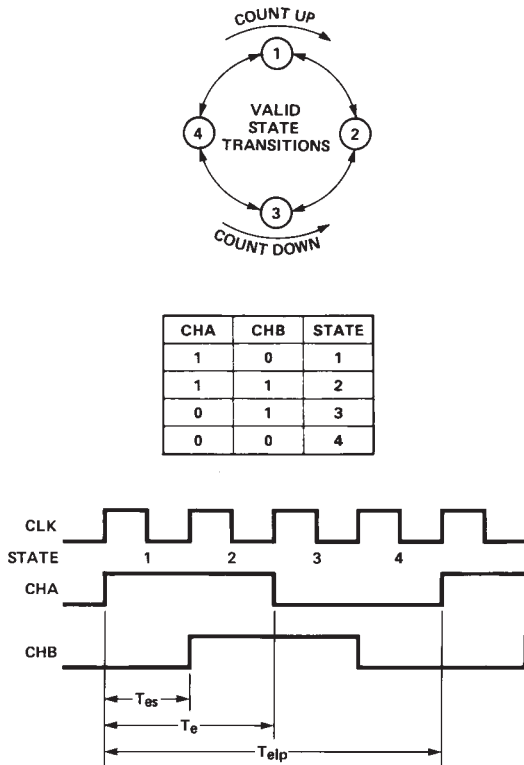

Figure 9. 4x Quadrature Decoding.

Position Counter

This section consists of a 12-bit (HCTL-2000) or 16-bit (HCTL- 2016/2020) binary up/down counter which counts on rising clock edges as explained in the Quadrature Decoder Section. All 12 or 16 bits of data are passed to the position data latch. The system can use this count data in several ways:

- A. System total range is ≤ 12 or 16 bits, so the count represents "absolute" position.
- B. The system is cyclic with ≤ 12 or 16 bits of count per cycle. \overline{RST} is used to reset the counter every cycle and the system uses the data to interpolate within the cycle.
- C. System count is $> 8, 12,$ or 16 bits, so the count data is used as a relative or incremental position input for a system software computation of absolute position. In this case counter rollover occurs. In order to prevent loss of position information, the processor must read the outputs of the IC before the count increments one-half of the maximum count capability (i.e. 127, 2047, or 32,767 quadrature counts). Two's complement arithmetic is normally used to compute position from these periodic position updates. Three modes can be used:
 1. The IC can be put in 8-bit mode by tying the SEL line high, thus simplifying IC interface. The outputs must then be read at least once every 127 quadrature counts.
 2. The HCTL-2000 can be used in 12-bit mode and sampled at least once every 2047 quadrature counts.
 3. The HCTL-2016 or 2020 can be used in 16-bit mode and sampled at least once every 32,767 quadrature counts.
- D. The system count is > 16 bits so the HCTL-2020 can be cascaded with other standard counter ICs to give absolute position.

Position Data Latch

The position data latch is a 12/ 16-bit latch which captures the position counter output data on each rising clock edge, except when its inputs are disabled by the inhibit logic section during two-byte read operations. The output data is passed to the bus interface section. When active, a signal from the inhibit logic section prevents new data from being captured by the latch, keeping the data stable while successive reads are made through the bus section. The latch is automatically reenabled at the end of these reads. The latch is cleared to 0 asynchronously by the \overline{RST} signal.

Inhibit Logic

The Inhibit Logic Section samples the \overline{OE} and SEL signals on the falling edge of the clock and, in response to certain conditions (see Figure 10 below), inhibits the position data latch. The \overline{RST} signal asynchronously clears the inhibit logic, enabling the latch. A simplified logic diagram of the inhibit circuitry is illustrated in Figure 11.

Bus Interface

The bus interface section consists of a 16 to 8 line multiplexer and an 8-bit, three-state output buffer. The multiplexer allows independent access to the low and high bytes of the position data latch. The SEL and \overline{OE} signals determine which byte is output and whether or not the output bus is in the high-Z state. In the case of the HCTL-2000 the data latch is only 12 bits wide and the upper four bits of the high byte are internally set to zero.

Step	SEL	\overline{OE}	CLK	Inhibit Signal	Action
1	L	L	\downarrow	1	Set inhibit; read high byte
2	H	L	\downarrow	1	Read low byte; starts reset
3	X	H	\downarrow	0	Completes inhibit logic reset

Figure 10. Two Byte Read Sequence.

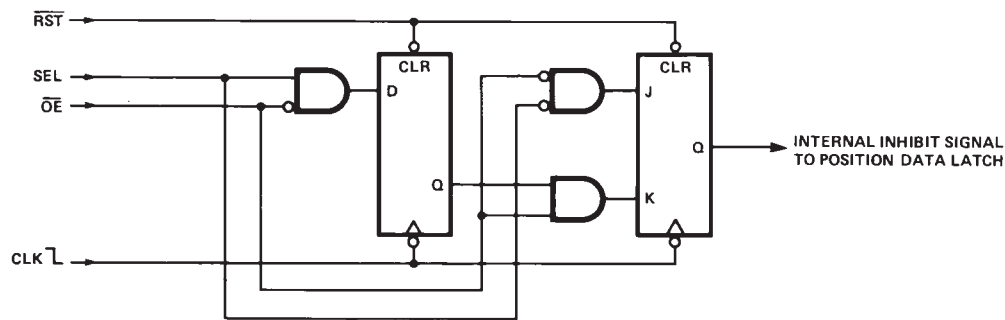

Figure 11. Simplified Inhibit Logic.

Quadrature Decoder Output (HCTL-2020 Only)

The quadrature decoder output section consists of count and up/ down outputs derived from the 4X decode logic of the HCTL- 2020. When the decoder has detected a count, a pulse, one-half clock cycle long, will be output on the CNT_{DCDR} pin. This output will occur during the clock cycle in which the internal counter is updated. The U/ \overline{D} pin will be set to the proper voltage level one clock cycle before the rising edge of the CNT_{DCDR} pulse, and held one clock cycle after the rising edge of the CNT_{DCDR} pulse. These outputs are not affected by the inhibit logic. See Figures 5 and 12 for detailed timing.

Cascade Output (HCTL-2020 Only)

The cascade output also consists of count and up/down outputs. When the HCTL-2020 internal counter overflows or underflows, a pulse, one-half clock cycle long, will be output on the CNT_{CAS} pin. This output will occur during the clock cycle in which the internal counter is updated. The U/ \overline{D} pin will be set to the proper voltage level one clock cycle before the rising edge of the CNT_{CAS} pulse, and held one clock cycle after the rising edge of the CNT_{CAS} pulse. These outputs are not affected by the inhibit logic. See Figures 5 and 12 for detailed timing.

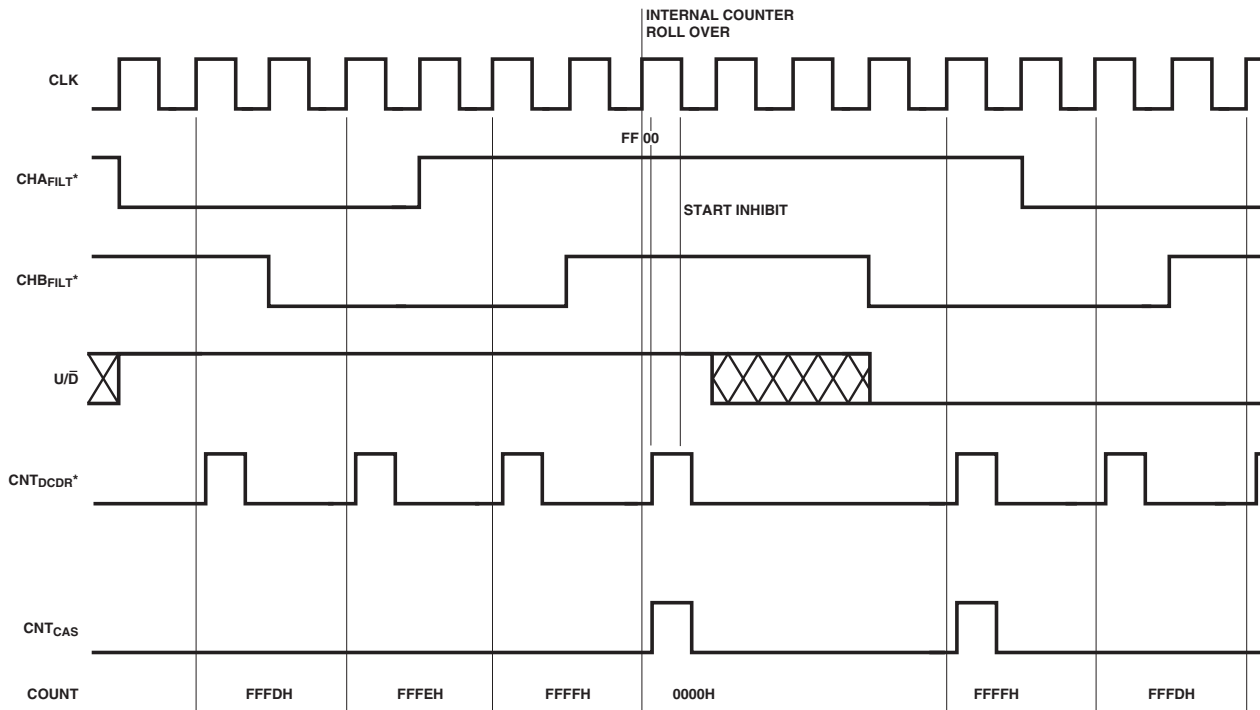

*CHA_{FILT} AND CHB_{FILT} ARE THE OUTPUTS OF THE DIGITAL NOISE FILTER (SEE FIGURES 7 AND 8).

Figure 12. Decode and Cascade Output Diagram.

Cascade Considerations (HCTL-2020 Only)

The HCTL-2020's cascading system allows for position reads of more than two bytes. These reads can be accomplished by latching all of the bytes and then reading the bytes sequentially over the 8-bit bus. It is assumed here that, externally, a counter followed by a latch is used to count any count that exceeds 16 bits. This configuration is compatible with the HCTL-2020 internal counter/latch combination.

Consider the sequence of events for a read cycle that starts as the HCTL-2020's internal counter rolls over. On the rising clock edge, count data is updated in the internal counter, rolling it over. A count-cascade pulse (CNT_{CAS}) will be generated with some delay after the rising clock edge (t_{CHD}). There will be additional propagation delays through the external counters and registers. Meanwhile, with SEL and \overline{OE} low to start the read, the internal latches are inhibited at the falling edge and do not update again till the inhibit is reset. If the CNT_{CAS} pulse now toggles the external counter and this count gets latched a major count error will occur. The count error is because the external latches get updated when the internal latch is inhibited.

Valid data can be ensured by latching the external counter data when the high byte read is started (SEL and \overline{OE} low). This latched external byte corresponds to the count in the inhibited internal latch. The cascade pulse that occurs during the clock cycle when the read begins gets counted by the external counter and is not lost. For example, suppose the HCTL-2020 count is at FFFFh and an external counter is at F0h, with the count going up. A count occurring in the HCTL-2020 will cause the counter to roll over and a cascade pulse will be generated. A read starting on this clock cycle will show FFFFh from the HCTL-2020. The external latch should read F0h, but if the host latches the count after the cascade signal propagates through, the external latch will read F1h.

General Interfacing

The 12-bit (HCTL-2000) or 16-bit (HCTL-2016/2020) latch and inhibit logic allows access to 12 or 16 bits of count with an 8-bit bus. When only 8-bits of count are required, a simple 8-bit (1- byte) mode is available by holding SEL high continuously. This disables the inhibit logic. \overline{OE} provides control of the tri-state bus, and read timing is shown in Figures 2 and 3.

For proper operation of the inhibit logic during a two-byte read, \overline{OE} and SEL must be synchronous with CLK due to the falling edge sampling of \overline{OE} and SEL.

The internal inhibit logic on the HCTL-20XX family inhibits the transfer of data from the counter to the position data latch during the time that the latch outputs are being read. The inhibit logic allows the microprocessor to first read the high order 4 or 8 bits from the latch and then read the low order 8 bits from the latch. Meanwhile, the counter can continue to keep track of the quadrature states from the CHA and CHB input signals.

Figure 11 shows the simplified inhibit logic circuit. The operation of the circuitry is illustrated in the read timing shown in Figure 13.

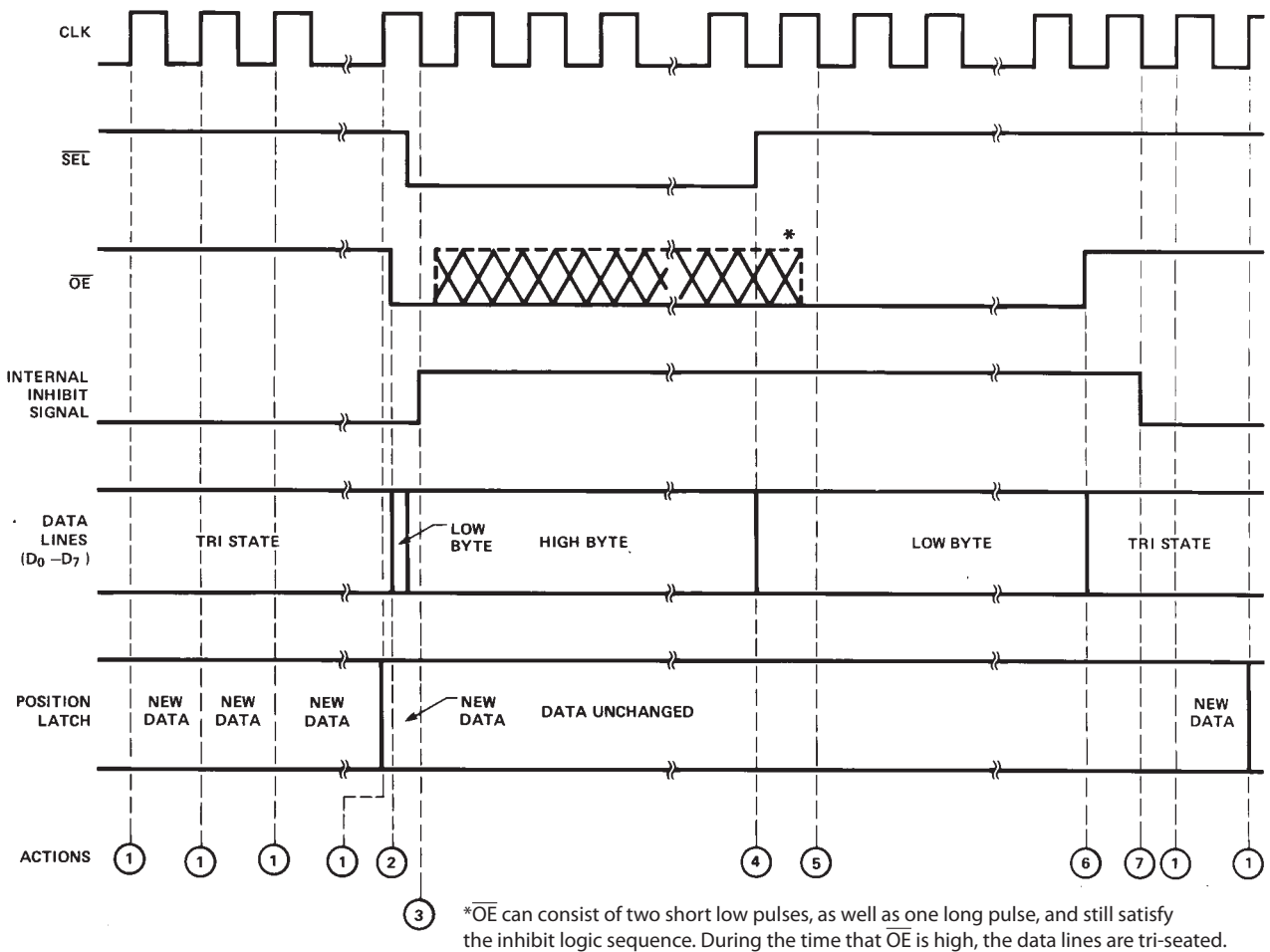

Figure 13. Typical Interface Timing.

Actions

1. On the rising edge of the clock, counter data is transferred to the position data latch, provided the inhibit signal is low.
2. When \overline{OE} goes low, the outputs of the multiplexer are enabled onto the data lines. If SEL is low, then the high order data bytes are enabled onto the data lines. If SEL is high, then the low order data bytes are enabled onto the data lines.
3. When the IC detects a low on \overline{OE} and SEL during a falling clock edge, the internal inhibit signal is activated. This blocks new data from being transferred from the counter to the position data latch.
4. When SEL goes high, the data outputs change from the high byte to the low byte.
5. The first of two reset conditions for the inhibit logic is met when the IC detects a logic high on SEL and a logic low on \overline{OE} during a falling clock edge.
6. When \overline{OE} goes high, the data lines change to a high impedance state.
7. The IC detects a logic high on \overline{OE} during a falling clock edge. This satisfies the second reset condition for the inhibit logic.

Interfacing the HCTL-2020 to a Motorola 6802/8 and Cascading the Counter for 24 Bits

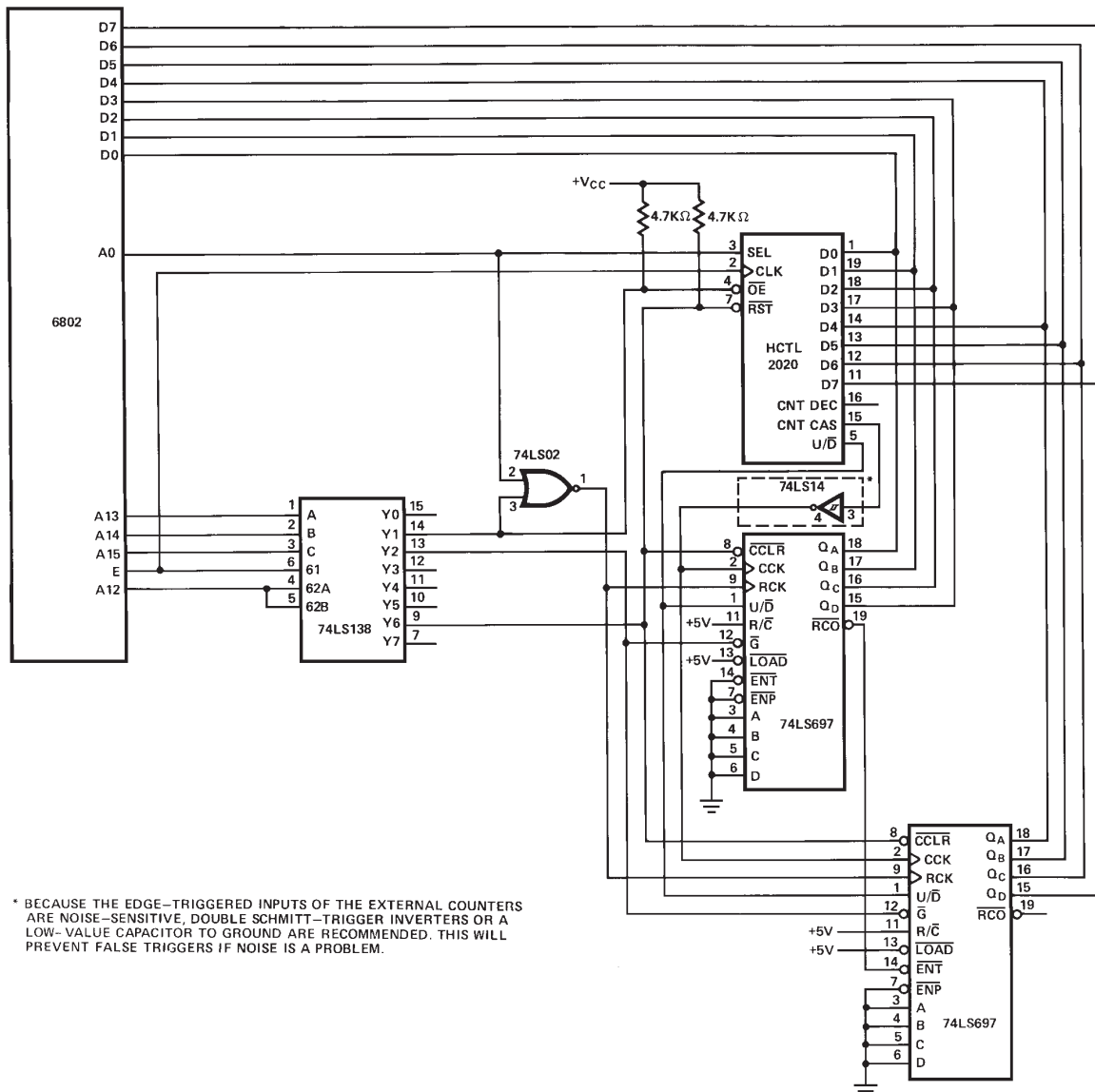

Figure 14. A Circuit to Interface to the 6802/8.

In this circuit an interface to a Motorola 6802/8 and a cascading scheme for a 24-bit counter are shown. This circuit provides a minimum part count by: 1) using two 74LS697 Up/Down counters with output registers and tri-state outputs and 2) using a Motorola 6802/8 LDX instruction which stores 16 bits of data into the index registers in two consecutive clock cycles.

The HCTL-2020 \overline{OE} and the 74LS697 \overline{G} lines are decoded from Address lines A15-A13. This results in counter data being enabled onto the bus whenever an external memory access is made to locations 4XXX or 2XXX. Address line A12 and processor clock E enables the 74LS138. The processor clock E is also used to clock the HCTL-2020. Address AO is connected directly to the SEL pin on the HCTL- 2020. This line selects the low or high byte of data from the HCTL-2020.

Address	Function
CXXX	Reset Counters
4XXX	Enable High Byte on Data Lines
2XX0	Enable Mid Byte on Data Lines
2XX1	Enable Low Byte on Data Lines

Read Example	
LDX 2000	Loads mid byte and then low byte into
STX 0100	memory locations 0100 and 0101
LDAA 4000	Loads the high byte into memory
STAA 0102	location 0102

Figure 15. Memory Addresses and Read Example.

Cascading is accomplished by connecting the CNTCAS output on the HCTL-2020 with the counter clock (CCK) input on both 74LS697s. The $\overline{U/\overline{D}}$ pin on the HCTL-2020 and the $\overline{U/\overline{D}}$ pin on both 74LS697s are also directly connected for easy expansion. The \overline{RCO} of the first 4-bit 74LS697 is connected to the \overline{ENT} pin of the second 74LS697. This enables the second counter only when there is a \overline{RCO} signal on the first counter.

This configuration allows the 6802 to read both data bytes with a single double-byte fetch instruction (LDX 2XX0). This instruction is a five cycle instruction which reads external memory location 2XX0 and stores the high order byte into the high byte of the index register. Memory location 2XX1 is next read and stored in the low order byte of the index register. The high byte of counter data is clocked into the 74LS697 registers when SEL is low and \overline{OE} goes low. This upper byte can be read at any time by pulling the 74LS697 \overline{G} low when reading address 4XXX. Figure 15 shows memory addresses and gives an example of reading the HCTL- 2020. Figure 16 shows the interface timing for the circuit.

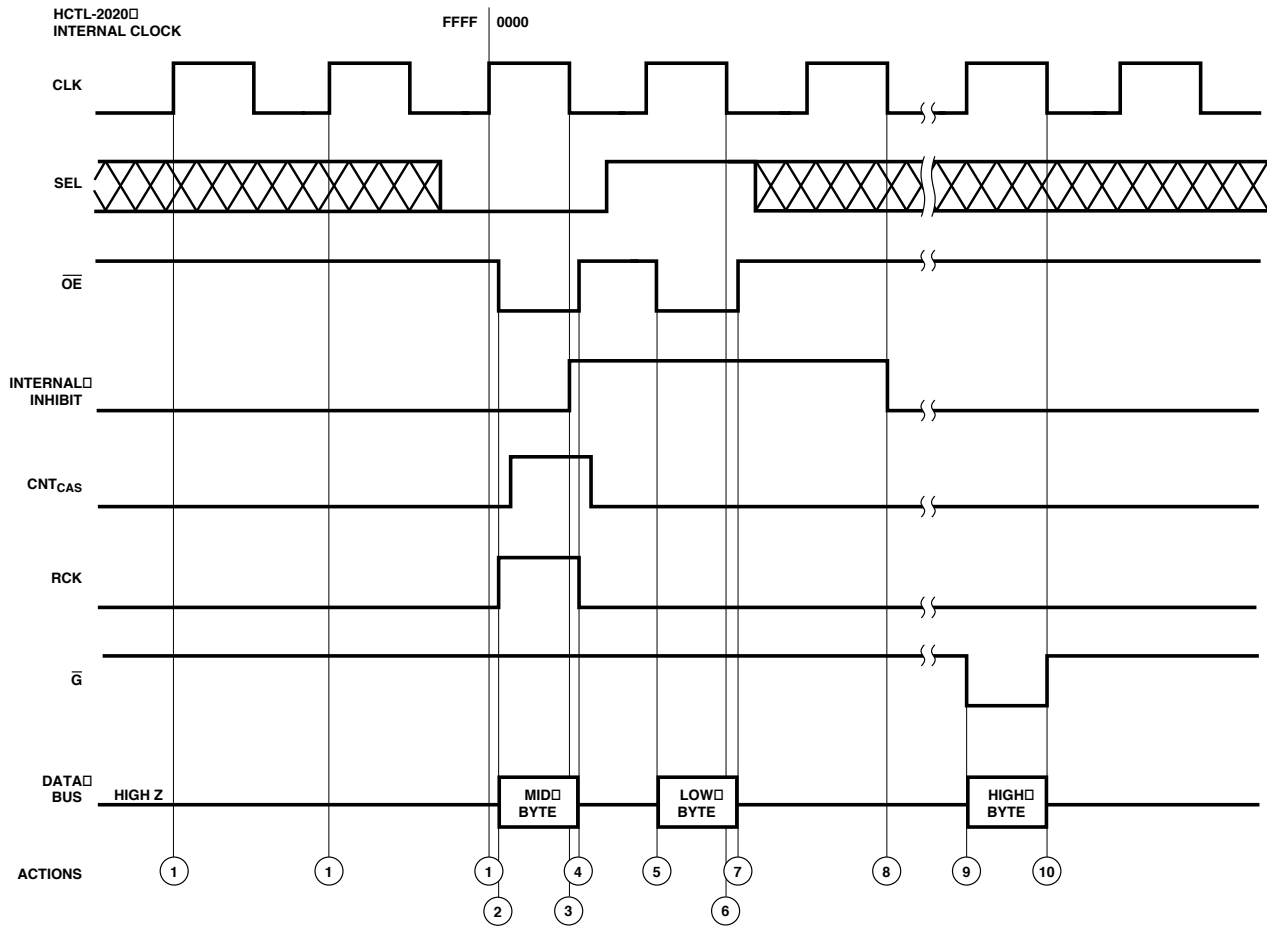

Figure 16. Interface Timing for the 6802/8.

Actions

1. The microprocessor clock output is E. If the internal HCTL-2020 inhibit is not active, new data is transferred from the internal counter to the position data latch.
2. An even address output from the 6802 causes SEL to go low. When E goes high, the address decoder output for the HCTL-2020 OE signal goes low. This causes the HCTL-2020 to output the middle byte of the system counter (high byte of the HCTL-2020 counter). This middle byte, FFFFH is available at (2) through (4), the first time \overline{OE} is low. In this example an overflow has occurred and \overline{OE} has been pulled low to start a read cycle. SEL and \overline{OE} are gated to give \overline{RCK} which latches the external high byte, equal to 00H. The falling edge, of the CNT_{CAS} signal counts up the external counter to 0001H.
3. With the first negative edge of the clock after SEL and \overline{OE} are low the internal latches are inhibited from counting and the 6802 reads the high byte in.
4. \overline{OE} goes high and the data bus goes into a high impedance state.
5. \overline{OE} is low and SEL is high and the low byte is enabled onto the data bus. The low byte is valid through (7).
6. With the first negative edge after \overline{OE} and SEL go high, the first of the two HCTL-2020 inhibit reset conditions is met and the 6802 reads the low byte in.
7. The data bus returns to the high impedance state, when \overline{OE} goes high.
8. With the first negative edge of the clock after \overline{OE} goes high, inhibit reset is complete.
9. With the positive going edge of the clock, \overline{G} is asserted and the external high byte, 00H is available on the data bus from 9 through 10 and the 6802 reads the high byte in at (10).

Interfacing the HCTL-20XX to an Intel 8748

The circuit shown in Figure 17 shows the connections between an HCTL-20XX and an 8748. Data lines D0-D7 are connected to the 8748 bus port. Bits 0 and 1 of port 1 are used to control the \overline{OE} and SEL inputs of the HCTL-20XX respectively. T0 is used to provide a clock signal to the HCTL-20XX. The frequency of T0 is the crystal frequency

divided by 3. T0 must be enabled by executing the ENT0 CLK instruction after each system reset, but prior to the first encoder position change. An 8748 program which interfaces to the circuit in Figure 17 is given in Figure 18. The resulting interface timing is shown in Figure 19.

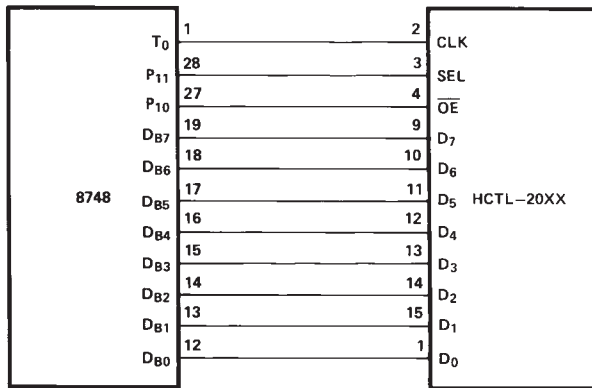

* Note: Pin numbers are different for the HCTL-2020.

Figure 17. An HCTL-20XX-to-Intel 8748 Interface.

LOC	Object Code	Source Statements	Comments
000	99 00	ANL P1, 00H	Enable output and higher order bits
002	08	INS A, BUS	Load higher order bits into ACC
003	A8	MOVE R0, A	Move data to register 0
004	89 02	ORL P1, 02H	Enable output and lower order bits
006	08	INS A, BUS	Load order bits into AC
008	A9	MOV R1, A	Move data to register 1
009	89 03	ORL P1, 03H	Disable outputs
00B	93	RETR	Return

Figure 18. A Typical Program for Reading HCTL-20XX with an 8748.

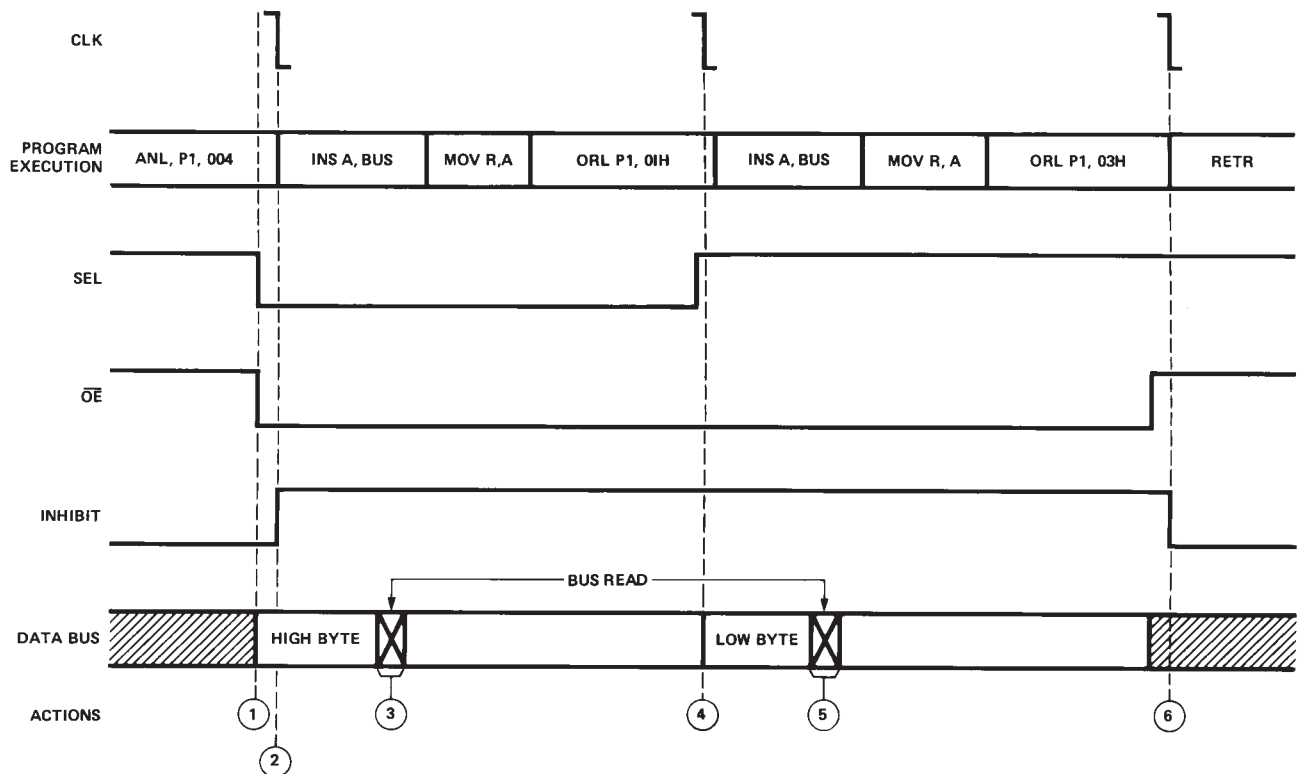

Figure 19. 8748 READ Cycle from Figure 18.

Actions

1. ANL P1, 00H has just been executed. The output of bits 0 and 1 of Port 1 cause SEL and \overline{OE} to be logic low. The data lines output the higher order byte.
2. The HCTL-20XX detects that \overline{OE} and SEL are low on the next falling edge of the CLK and asserts the internal inhibit signal. Data can be read without regard for the phase of the CLK.
3. INS A, BUS has just been executed. Data is read into the 8748.
4. ORL PORT 1, 02H has just been executed. The program sets SEL high and leaves OE low by writing the correct values to port 1. The HCTL- 20XX detects \overline{OE} is low and SEL is high on the next falling edge of the CLK, and thus the first inhibit reset condition is met.
5. INS A, BUS has just been executed. Lower order data bits are read into the 8748.
6. ORL P1, 03H has just been executed. The HCTL-20XX detects \overline{OE} high on the next falling edge of CLK. The program sets \overline{OE} and SEL high by writing the correct values to port 1. This causes the data lines to be tristated. This satisfies the second inhibit and reset condition. On the next rising CLK edge new data is transferred from the counter to the position data latch.

Additional Information from Avago Technologies

Application briefs are available from the factory. Please contact your local Avago sales representative for the following.

M027 Interfacing the HCTL-20XX to the 8051

M019 Commonly Asked Questions about the HCTL- 2020 and Answers

M020 A Simple Interface for the HCTL-2020 with a 16-bit DAC without Using a Processor

M023 Interfacing the MC68HC11 to the HCTL-2020

For product information and a complete list of distributors, please go to our web site: www.avagotech.com

Avago, Avago Technologies, and the A logo are trademarks of Avago Technologies in the United States and other countries.
Data subject to change. Copyright © 2005-2012 Avago Technologies. All rights reserved. Obsoletes 5988-5895EN
AV02-3800EN - September 12, 2012

