

User Guide

Quick-Start Guide

Once visual inspection is done to ensure that the Evaluation Board is received in good condition, the Evaluation Board can be powered up in just 3 simple steps according to Figure 1 as shown:

1. Select either one of the provided sensing resistors (10mΩ or 15mΩ), or user's own sensing resistor and mount it (through soldering) on pads provided for R1 on the Evaluation Board;
2. Connect the necessary power supplies and current source as shown:
 - a. Connect 1st isolated 5V DC supply (DC Supply 1) to connector CON1 as shown;
 - b. Connect a 3.3V DC supply (DC Supply 2, can be non-isolated) to connector CON2 as shown;
 - c. Connect, through soldering, the required input current source (for sensing) cables as shown;
3. Supply the input current (subject to a maximum signal level of 250mVpp, or $\pm 125\text{mVdc}$ across resistor R1) through the cables (as shown in 2c) and monitor the output through an oscilloscope.

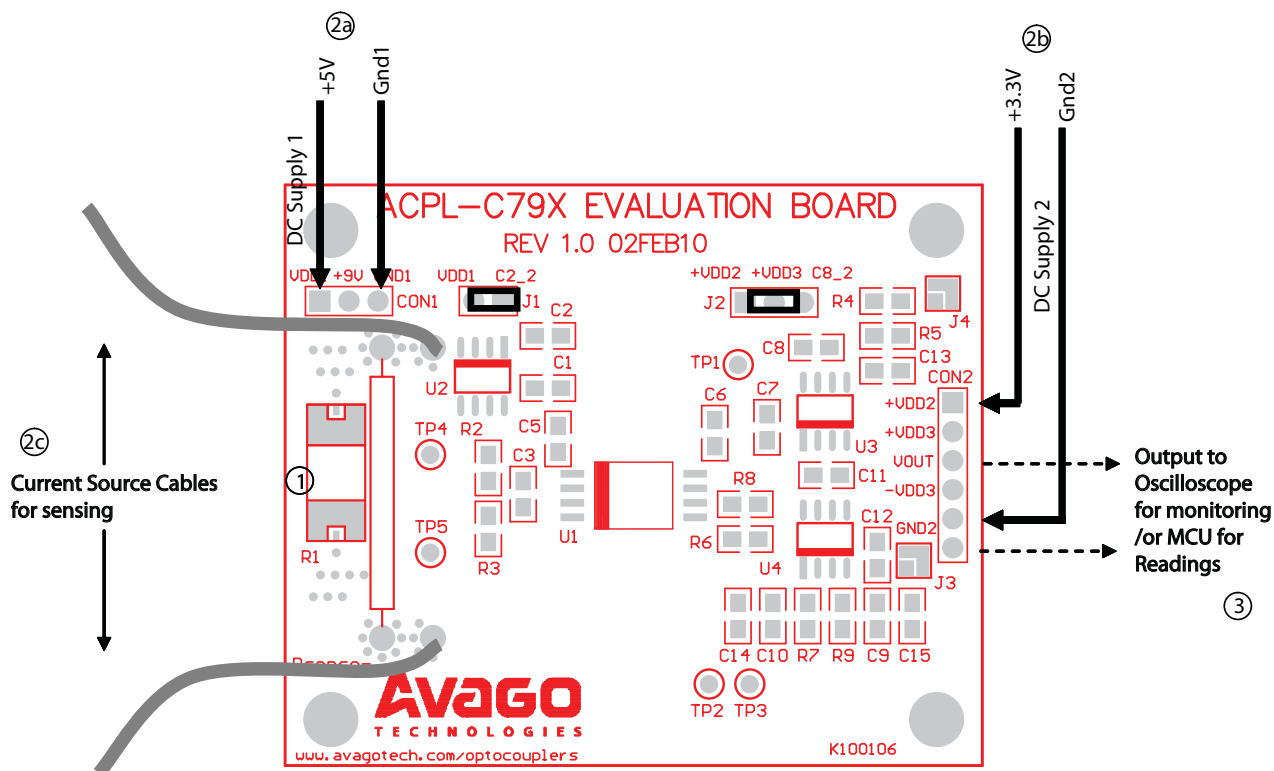

Figure 1. Default Test Setup of Evaluation Board

Schematics

Schematics of the Evaluation Board are as shown in Figure 2.

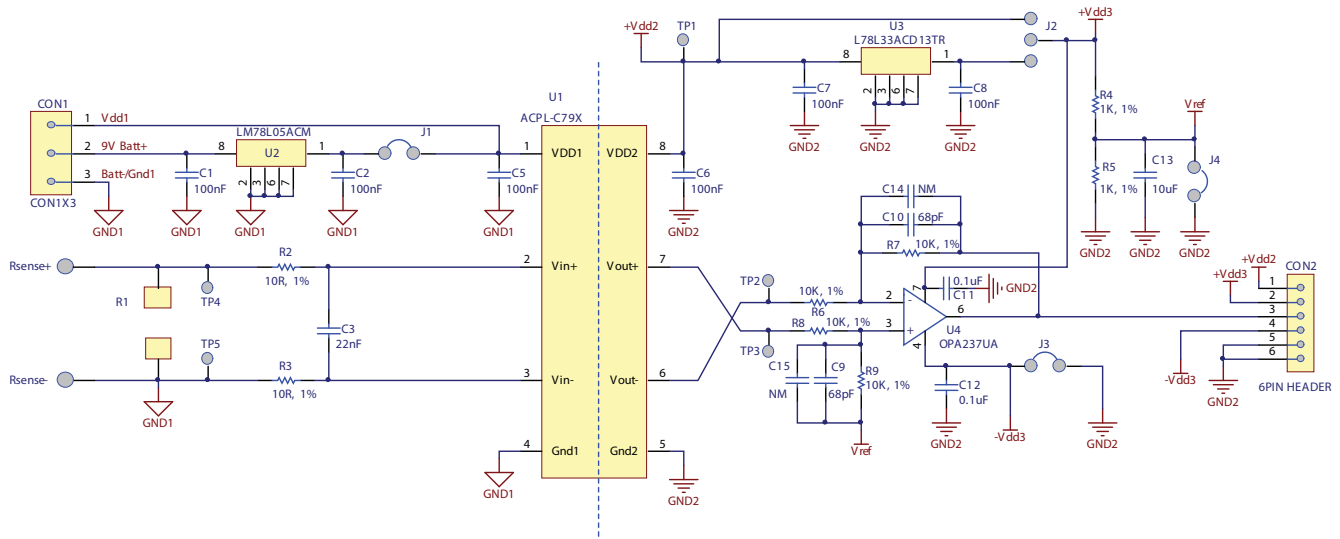

Figure 2. Schematics of ACPL-C79X Evaluation Board

Board Description

The ACPL-C79X evaluation boards (shown in Figure 3), can accommodate either a ACPL-C79B(0.5% tolerance), ACPL-C79A(1% tolerance), or ACPL-C790(3% tolerance) device on U1, to demonstrate the high linearity and low-offset capability of Avago's Isolation Amplifier over a wide range of input current conditions. It allows a designer to easily test the performance of the high-precision isolation amplifier in an actual application under real-life operating conditions. Many of the circuit recommendations discussed in Application Note 1078 are implemented on the board. Operation requires merely the addition of a 5V Supply and a low-resistance shunt resistor on the input side of the isolation amplifier. The board has holes for mounting a through-hole shunt, and pads for mounting a surface-mount shunt. The board may also be used for general voltage isolation without any shunt resistor.

As can be seen on the board, the isolation circuitry is easily contained within a small area while maintaining adequate spacing for good voltage isolation and easy assembly. The overall size of the evaluation board has been enlarged to allow mounting of feet for stand-alone use (using the 4 drilled holes at the corners of the board).

Using the Board

The evaluation board is easily prepared for use. Only minor preparations (just by soldering of shunt resistor, wires for power / sense current path and output signal) are required. The evaluation board is having a default setup 1 as shown in the tables when shipped to customer. Customer is free to choose any one of the 6 setup configurations as shown in the tables by setting J1, J2, J3 and J4 as shown.

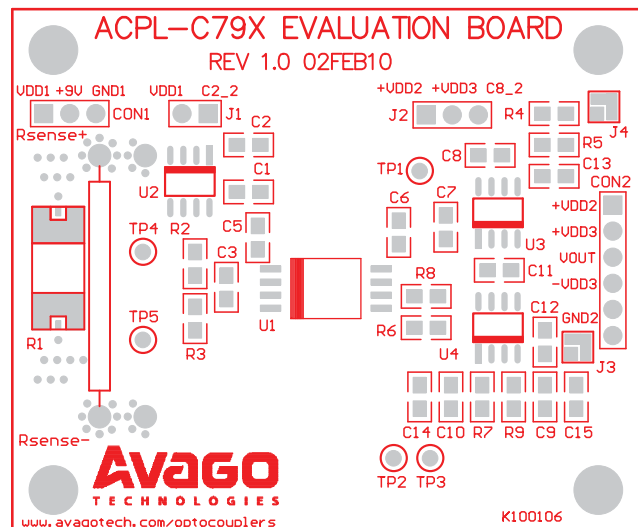

Figure 3. Top View of ACPL-C79X Evaluation Board

Table 1.

	Recommended Vin for better linearity [1]	Vdd1	Vdd2	Vdd3	-Vdd3
Default Setup 1	<230mVpp	+5Vdc	+3.3Vdc	+3.3Vdc	0V
Setup 2	<500mVpp	+5Vdc	+3.3Vdc	+3.3Vdc	-3.3Vdc
Setup 3	<230mVpp	+5Vdc	+5Vdc	+3.3Vdc	0V
Setup 4	<500mVpp	+5Vdc	+5Vdc	+3.3Vdc	-3.3Vdc
Setup 5	<440mVpp	+5Vdc	+5Vdc	+5Vdc	0V
Setup 6	<550mVpp	+5Vdc	+5Vdc	+5Vdc	-5Vdc

Notes

1. Linear input range is limited by the post-amp output swing range. To avoid this limitation, directly measure the VOUT+, VOUT- of the isolation amplifier.

In order to satisfy the above Vdd1, Vdd2, Vdd3 and -Vdd3 voltages, J1, J2, J3 and J4 must be set according to the table as shown below:

Table 2.

	J1 [1]	J2	J3	J4	Remarks
Default Setup 1	Always shorted	Shorting Vdd2 & Vdd3 pins	Short	Open	Only 2 external supplies (+5V Vdd1 & isolated +3,3V for Vdd2) are needed
Setup 2	Always shorted	Shorting Vdd2 & Vdd3 pins	Open	Short	3 external supplies (+5V Vdd1, isolated +3,3V for Vdd2 and Vdd3, while isolated -3,3V for -Vdd3) are needed.
Setup 3	Always shorted	Shorting Vdd3 & C8_2 pins	Short	Open	Only 2 external supplies (+5V Vdd1 & isolated +5V for Vdd2) are needed, Vdd3 is obtained thru converter U3.
Setup 4	Always shorted	Shorting Vdd3 & C8_2 pins	Open	Short	3 external supplies (+5V Vdd1 & isolated +5V for Vdd2, while isolated -3,3V for -Vdd3) are needed, Vdd3 is obtained thru converter U3.
Setup 5	Always shorted	Shorting Vdd2 & Vdd3 pins	Short	Open	Only 2 external supplies (+5V Vdd1 & isolated +5V for Vdd2 & Vdd3) are needed.
Setup 6	Always shorted	Shorting Vdd2 & Vdd3 pins	Open	Short	3 external supplies (+5V Vdd1, isolated +5V for Vdd2 & Vdd3, while isolated -5V for -Vdd3) are needed.

Notes

1. To obtain +5Vdc at Vdd1, a 9V Battery can be connected across Pin-2 and 3 of CON1 connector or by connecting an external +5V DC supply directly to Pin-1 and 3 of CON1 connector. J1 can be left shorted permanently unless U2 is non-functioning.

The output signal is measured between the "Vout" and "GND2" terminals (at the output side of the board). With all connections made and power supplies turned on, the approximate relationship of output voltage to input current is:

$$V_{OUT} = 8.2 \times V_{IN}, \text{ where}$$

$$V_{IN} = R_{SENSE} \times I_{IN};$$

With the shunt resistor in place, the maximum differential input voltage swing for linear operation is $\pm 200\text{mV}$ as specified in the datasheet. However, input voltage as high as $\pm 300\text{mV}$ can be safely applied with minimal performance degradation.

When 68pF capacitance is selected for both C9 and C10, the bandwidth will be limited to 150kHz. To obtain 200kHz bandwidth, change both C9 & C10 to 47pF.

Output Measurement

A sample V_{out} against V_{in} waveforms are captured and shown in Figure 4 below.

(Orange and Green traces are the input and output voltages respectively).

$V_{IN+} = 100 \text{ mV}, 50\text{kHz}$.

V_{out} is taken at U4 V_{out} node, which is at pin-3 of Connector CON2.

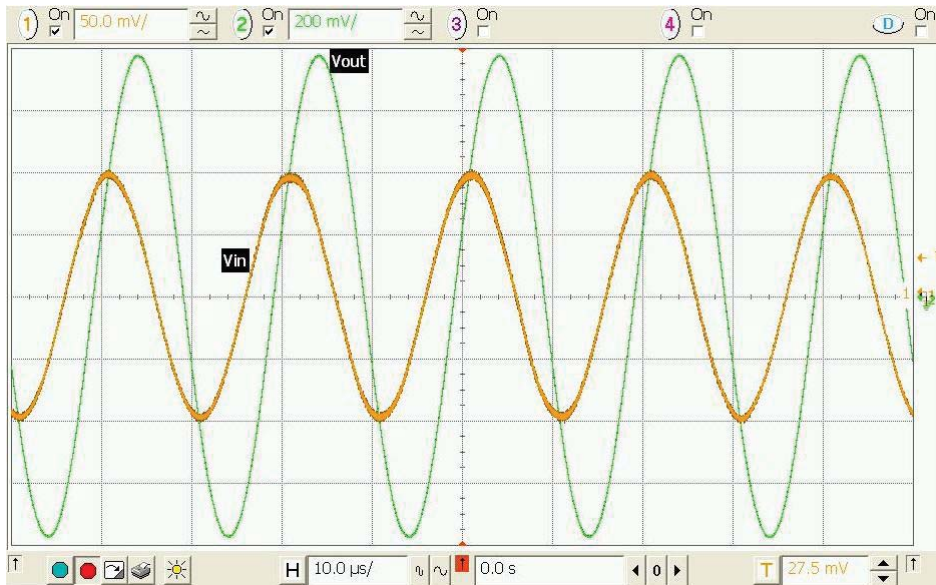

Figure 4. V_{out} vs V_{in} Voltage Waveforms

For product information and a complete list of distributors, please go to our web site: www.avagotech.com

Avago, Avago Technologies, and the A logo are trademarks of Avago Technologies in the United States and other countries. Data subject to change. Copyright © 2005-2011 Avago Technologies. All rights reserved. AV02-2502EN - July 14, 2011

AVAGO
TECHNOLOGIES