

SMT Modular Jack Series

KLS12-SMT11-8P SMT Modular Jack Series With shielded

ELECTRICAL

- 1.Voltage Rating: 125VAC
- 2.Current Rating: 1.5A
- 3.Contact Resistance: 30MΩ Max.
- 4.Insulation Resistance: 500MΩ Min.@500VDC
- 5.Withstanding Resistance :1000VAC RMS. 50Hz 1minute

MATERIALS

- 1.Housing: High Temp. Thermoplastic Flammability UL 94V-0
- 2.Contact: Phosphor Bronze Flat Pin
- 3.Plating:Gold Plating over nickel in contact,Tin Planting over nickel in solder area
- 4.Shield: 0.23 Thickness Brass With Nickel Plated

MECHANICAL

- 1.Durability: 750 cycles Min.
- 2.PCB Retention pre-solder: 1 LB Min.

ENVIRONMENTAL

- 1.Storage:-40 C ~ +80 C

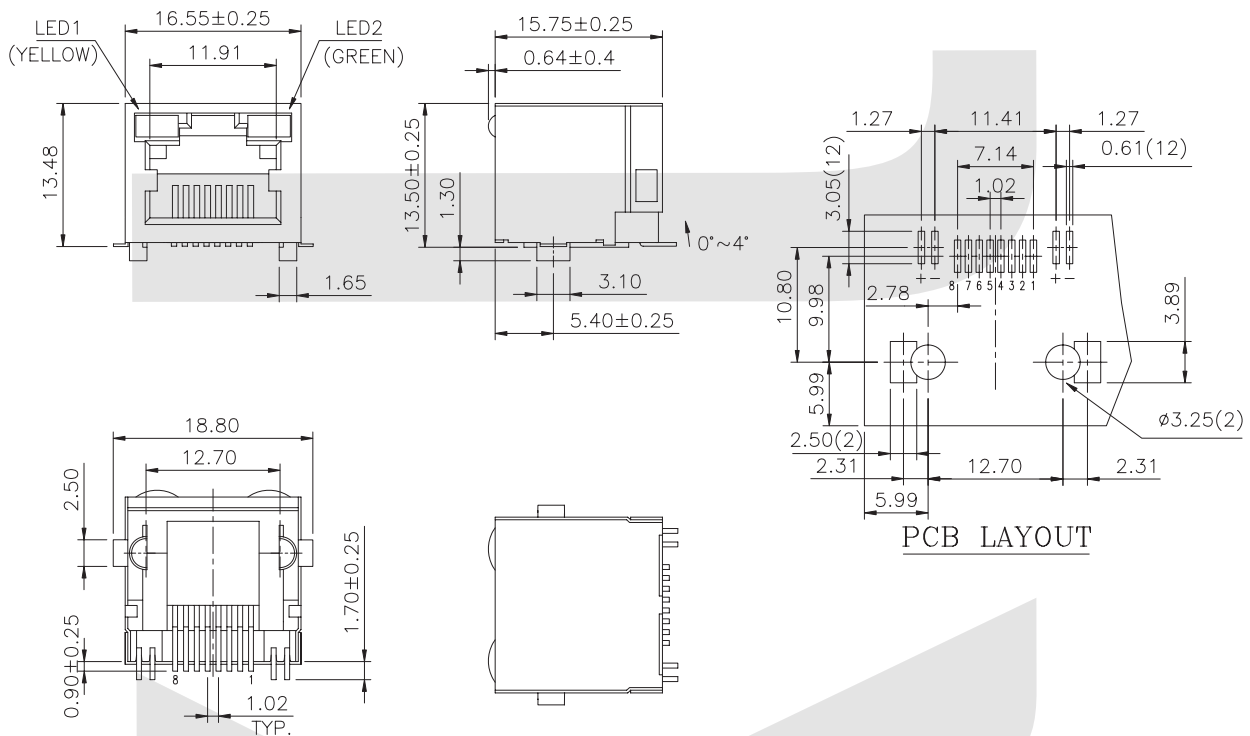
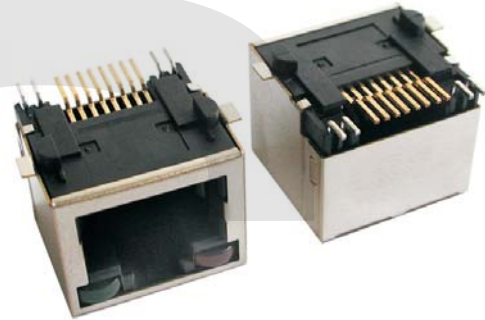

ORDER INFORMATION

KLS12-SMT11-8P8C - 03

Part Number	Point No.	Gold Thickness
	8P8C Point	01-Fu " 03-6u " 05-30u " 06-50u "