



WINSTAR Display Co.,Ltd.
華凌光電股份有限公司



WINSTAR Display Co.,Ltd.

華凌光電股份有限公司

■ www.winstar.com.tw ■ E-mail/Sales@winstar.com.tw

TFT LCM 檢驗規範

(TFT LCM Inspection Specification)

MODLE NO :

RECORDS OF REVISION

DOC. FIRST ISSUE

VERSION	DATE	REVISED PAGE NO.	SUMMARY
0	2013/04/23		First issue
A	2013/09/24	5	Correct the inspection standard of no 5 scratch contamination Line type $0.01\text{mm} < W \leq 0.05\text{mm}$
B	2016/09/09	2	Mura and bright dot inspected through 6% transmission ND Filter as following

檢驗規範(Inspection Specification)

1. 範圍(Scope)：適用於本公司 TFT-LCD 模塊(The document shall be applied to TFT-LCD Module)
2. 檢驗標準(Inspection Standard)：MIL-STD-105E 正常單次抽樣水平 II(MIL-STD-105E Table Normal Inspection Single Sampling Level II)
3. 缺陷水平(Defect Level)：主要缺陷 AQL：0.65;次要缺陷 AQL：2.5(Major Defect AQL:0.65;Minor Defect AQL:2.5)
4. 檢驗條件(Test conditions):
 - (1)溫度(Temperature)：15°C~25°C；溼度(Humidity)：55 ±15%
 - (2)外觀檢驗(Visual inspection)：光照強度：500 Lux 以上;檢查距離：20cm~30cm (Illumination：More than 500 Lux; Inspection Distance: 20cm~30cm)
 - (3)電性檢驗(Electrical inspection)：光照強度：100Lux~300Lux;檢查距離：20cm~30cm(Illumination：100Lux~300Lux; Inspection Distance: 20cm~30cm)
 - (4)目視角度(Visual angle)：檢查目視的角度是法線方法的 45 °(The test direction is base on about around 45° of Vertical line)

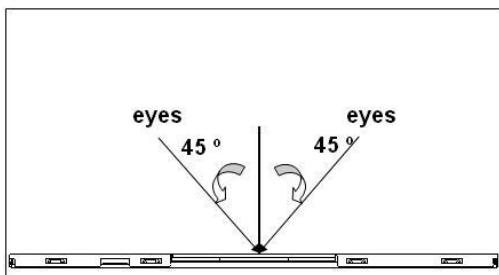

- (5)定義區域(Definition of area):

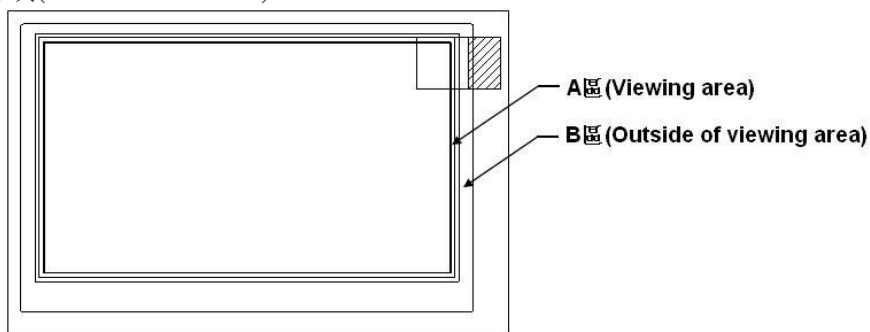

5. 象素定義 (Pixel Definition):

R	G	B	R	G	B	R	G	B		Dot Defect
R	G	B	R	G	B	R	G	B		Adjacent Dot Defect
R	G	B	R	G	B	R	G	B		Cluster

Note 1: If pixel or partial sub-pixel defects exceed 50% of the affected pixel or sub-pixel area, it shall be considered as 1 defect.

Note 2: There should be no distinct non-uniformity visible through 6% ND Filter within 2 sec inspection times.

6. Mura and bright dot inspected through 6% transmission ND Filter as following.

1. 檢驗標準(Inspection Standard) :

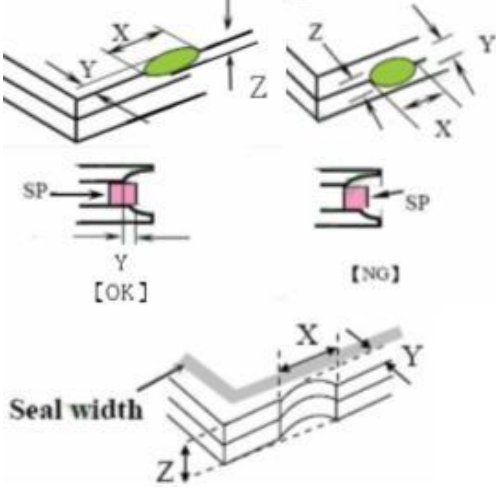
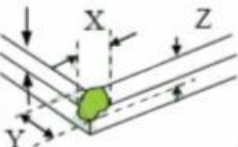
項次 (No)	檢驗項目(Inspection item)	檢驗標準(Inspection Standard)	缺陷等級 (Defect Level)									
1	PACKING & INDICATE	1.1.不可有混入其他型號產品的現象(Mixde product types). 1.2.不可有產品漏工序的現象(The part number is inconsistent with work order of production). 1.3.不可有部件裝反方向的現象(Assembled in inverse direction). 1.4.不可有數量與實際要求不一致的現象(The quantity is inconsistent with work order of production).	主缺 (Maj)									
2	尺寸(Size)	产品尺寸和结构必须符合结构图(Product size and structure must meet the structure diagram)	主缺 (Maj)									
3	玻璃裂纹 (The crack of glass)	<p>符號(Symbols): X:破裂長度(Symbols) Y:破裂寬度(The width of crack). Z:破裂厚度(The thickness of crack). W:出電極區寬度(Terminal length) T:玻璃厚度(The thickness of glass). a:LCD 側面長度(LCD side length).</p> <p>3.1.一般玻璃破損(General glass chip): 3.1.1.玻璃表面或上、下玻璃組合縫隙之間破損(Chip on panel surface and crack between panels);</p>  <table border="1" data-bbox="528 1585 1275 1803"> <thead> <tr> <th>X</th> <th>Y</th> <th>Z</th> </tr> </thead> <tbody> <tr> <td>$\leq a$</td> <td>裂紋進入 VA 區(Crack can't enter viewing area)</td> <td>$\leq 1/2t$</td> </tr> <tr> <td>$\leq a$</td> <td>裂紋超過 SP 一半的寬度(Crack can't exceed the half of SP width)</td> <td>$1/2t < Z \leq 2t$</td> </tr> </tbody> </table> <p>3.1.2.邊角破損(Corner crack) :</p> 	X	Y	Z	$\leq a$	裂紋進入 VA 區(Crack can't enter viewing area)	$\leq 1/2t$	$\leq a$	裂紋超過 SP 一半的寬度(Crack can't exceed the half of SP width)	$1/2t < Z \leq 2t$	次缺 (Min)
X	Y	Z										
$\leq a$	裂紋進入 VA 區(Crack can't enter viewing area)	$\leq 1/2t$										
$\leq a$	裂紋超過 SP 一半的寬度(Crack can't exceed the half of SP width)	$1/2t < Z \leq 2t$										

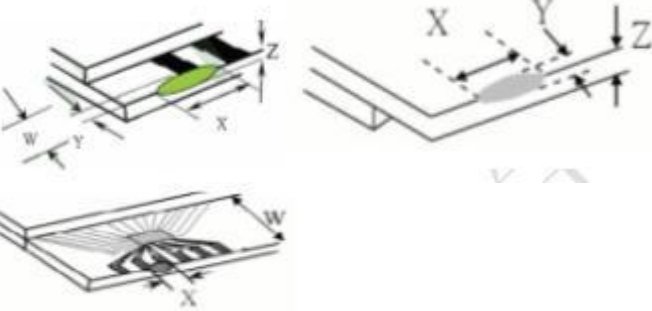
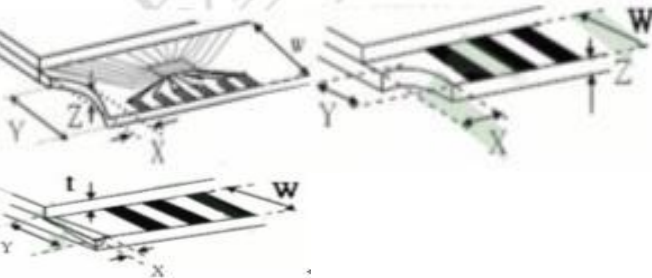
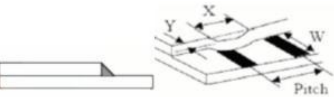
項次 (No)	檢驗項目 (Inspection item)	檢驗標準 (Inspection Standard)	缺陷等級 (Defect Level)										
3	玻璃裂紋 (The crack of glass)	<table border="1"> <thead> <tr> <th>X</th> <th>Y</th> <th>Z</th> </tr> </thead> <tbody> <tr> <td>$\leq 1/5a$</td> <td>裂紋進入 VA 區 (Crack can't enter viewing area)</td> <td>$\leq 1/2t$</td> </tr> <tr> <td>$\leq 1/5a$</td> <td>裂紋超過 SP 一半的寬度 (Crack can't exceed the half of SP width)</td> <td>$1/2t < Z \leq 2t$</td> </tr> </tbody> </table>	X	Y	Z	$\leq 1/5a$	裂紋進入 VA 區 (Crack can't enter viewing area)	$\leq 1/2t$	$\leq 1/5a$	裂紋超過 SP 一半的寬度 (Crack can't exceed the half of SP width)	$1/2t < Z \leq 2t$	次缺 (Min)	
		X	Y	Z									
		$\leq 1/5a$	裂紋進入 VA 區 (Crack can't enter viewing area)	$\leq 1/2t$									
		$\leq 1/5a$	裂紋超過 SP 一半的寬度 (Crack can't exceed the half of SP width)	$1/2t < Z \leq 2t$									
<p>3.2.出电极端破损(Protrusion over terminal): 3.2.1.电极垫上破损(Chip on electrode pad):</p>  <table border="1"> <thead> <tr> <th>位置(Position)</th> <th>X</th> <th>Y</th> <th>Z</th> </tr> </thead> <tbody> <tr> <td>正面(Front)</td> <td>$\leq a$</td> <td>$\leq 1/2W$</td> <td>$\leq t$</td> </tr> <tr> <td>背面(Back)</td> <td>$\leq a$</td> <td>$\leq W$</td> <td>$\leq 1/2t$</td> </tr> </tbody> </table>	位置(Position)	X	Y	Z	正面(Front)	$\leq a$	$\leq 1/2W$	$\leq t$	背面(Back)	$\leq a$	$\leq W$	$\leq 1/2t$	
位置(Position)	X	Y	Z										
正面(Front)	$\leq a$	$\leq 1/2W$	$\leq t$										
背面(Back)	$\leq a$	$\leq W$	$\leq 1/2t$										
<p>3.2.2.出電極端非電極破損(Non-conductive portion):</p>  <table border="1"> <thead> <tr> <th>X</th> <th>Y</th> <th>Z</th> </tr> </thead> <tbody> <tr> <td>$\leq 1/3a$</td> <td>$\leq W$</td> <td>$\leq t$</td> </tr> </tbody> </table>	X	Y	Z	$\leq 1/3a$	$\leq W$	$\leq t$							
X	Y	Z											
$\leq 1/3a$	$\leq W$	$\leq t$											
<p>備註(Note) : 如果破碎部分觸及 ITO 電極則不可超過 ITO 電極寬度的 1/3，且必須進行通電測試，不可影響顯示效果 (If the chipped area touches the ITO terminal, over 2/3 of the ITO must remain and be inspected according to electrode terminal specifications).</p> <p>3.2.3.玻璃破損(Glass remain) :</p>  <table border="1"> <thead> <tr> <th>X</th> <th>Y</th> <th>Z</th> </tr> </thead> <tbody> <tr> <td>$\leq a$</td> <td>$\leq 1/3W$</td> <td>$\leq t$</td> </tr> </tbody> </table>	X	Y	Z	$\leq a$	$\leq 1/3W$	$\leq t$							
X	Y	Z											
$\leq a$	$\leq 1/3W$	$\leq t$											

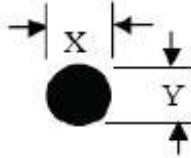
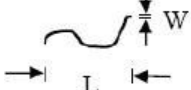
項次 (No)	檢驗項目(Inspection item)	檢驗標準(Inspection Standard)	缺陷等級 (Defect Level)																																		
4	黑點、白點異物 (Black or white dot)Round type 	4.1 Round type(Non-display or display): <table border="1" data-bbox="528 248 1276 741"> <thead> <tr> <th>尺寸 (Size)</th> <th colspan="2">判定標準(Judging standard)</th> <th>允收數量 (Acceptance(Q'ty))</th> </tr> </thead> <tbody> <tr> <td rowspan="3">1.44" ~ 4.9"</td> <td colspan="2">$D \leq 0.1 \text{ mm}$</td> <td>忽略不計(Ignore)</td> </tr> <tr> <td colspan="2">$0.10\text{mm} < D \leq 0.4\text{mm}$</td> <td>$N \leq 3$</td> </tr> <tr> <td colspan="2">$D > 0.4\text{mm}$</td> <td>$N \leq 0$</td> </tr> <tr> <td rowspan="3">5.0" ~7 .0"</td> <td colspan="2">$D \leq 0.25\text{mm}$</td> <td>忽略不計(Ignore)</td> </tr> <tr> <td colspan="2">$0.25\text{mm} < D \leq 0.5\text{mm}$</td> <td>$N \leq 4$</td> </tr> <tr> <td colspan="2">$D > 0.5\text{mm}$</td> <td>$N \leq 0$</td> </tr> <tr> <td rowspan="3">7.1" ~1 2.0"</td> <td colspan="2">$D \leq 0.3 \text{ mm}$</td> <td>忽略不計(Ignore)</td> </tr> <tr> <td colspan="2">$0.30\text{mm} < D \leq 0.5\text{mm}$</td> <td>$N \leq 5$</td> </tr> <tr> <td colspan="2">$D > 0.5\text{mm}$</td> <td>$N \leq 0$</td> </tr> </tbody> </table>	尺寸 (Size)	判定標準(Judging standard)		允收數量 (Acceptance(Q'ty))	1.44" ~ 4.9"	$D \leq 0.1 \text{ mm}$		忽略不計(Ignore)	$0.10\text{mm} < D \leq 0.4\text{mm}$		$N \leq 3$	$D > 0.4\text{mm}$		$N \leq 0$	5.0" ~7 .0"	$D \leq 0.25\text{mm}$		忽略不計(Ignore)	$0.25\text{mm} < D \leq 0.5\text{mm}$		$N \leq 4$	$D > 0.5\text{mm}$		$N \leq 0$	7.1" ~1 2.0"	$D \leq 0.3 \text{ mm}$		忽略不計(Ignore)	$0.30\text{mm} < D \leq 0.5\text{mm}$		$N \leq 5$	$D > 0.5\text{mm}$		$N \leq 0$	次缺 (Min)
尺寸 (Size)	判定標準(Judging standard)		允收數量 (Acceptance(Q'ty))																																		
1.44" ~ 4.9"	$D \leq 0.1 \text{ mm}$		忽略不計(Ignore)																																		
	$0.10\text{mm} < D \leq 0.4\text{mm}$		$N \leq 3$																																		
	$D > 0.4\text{mm}$		$N \leq 0$																																		
5.0" ~7 .0"	$D \leq 0.25\text{mm}$		忽略不計(Ignore)																																		
	$0.25\text{mm} < D \leq 0.5\text{mm}$		$N \leq 4$																																		
	$D > 0.5\text{mm}$		$N \leq 0$																																		
7.1" ~1 2.0"	$D \leq 0.3 \text{ mm}$		忽略不計(Ignore)																																		
	$0.30\text{mm} < D \leq 0.5\text{mm}$		$N \leq 5$																																		
	$D > 0.5\text{mm}$		$N \leq 0$																																		
5	刮痕、線狀異物 (scratch、 contamination) Line type 	5.1 Line type(Non-display or display): <table border="1" data-bbox="528 831 1276 1435"> <thead> <tr> <th rowspan="2">尺寸 (Size)</th> <th colspan="2">判定標準(Judging standard)</th> <th rowspan="2">允收數量 (Acceptance(Q'ty))</th> </tr> <tr> <th>W</th> <th>L</th> </tr> </thead> <tbody> <tr> <td rowspan="3">1.44" ~ 7.0"</td> <td>$W \leq 0.01\text{mm}$</td> <td>—</td> <td>忽略不計(Ignore)</td> </tr> <tr> <td>$0.01\text{mm} < W \leq 0.05\text{mm}$</td> <td>$L \leq 5\text{mm}$</td> <td>$N \leq 4$</td> </tr> <tr> <td>$W > 0.05\text{mm}$</td> <td>$L > 5\text{mm}$</td> <td>$N \leq 0$</td> </tr> <tr> <td rowspan="3">7.1" ~1 2.0"</td> <td>$W \leq 0.07\text{mm}$</td> <td>—</td> <td>忽略不計(Ignore)</td> </tr> <tr> <td>$0.07\text{mm} < W \leq 0.1\text{mm}$</td> <td>$L \leq 5\text{mm}$</td> <td>$N \leq 5$</td> </tr> <tr> <td>$W > 0.1\text{mm}$</td> <td>$L > 5\text{mm}$</td> <td>$N \leq 0$</td> </tr> </tbody> </table>	尺寸 (Size)	判定標準(Judging standard)		允收數量 (Acceptance(Q'ty))	W	L	1.44" ~ 7.0"	$W \leq 0.01\text{mm}$	—	忽略不計(Ignore)	$0.01\text{mm} < W \leq 0.05\text{mm}$	$L \leq 5\text{mm}$	$N \leq 4$	$W > 0.05\text{mm}$	$L > 5\text{mm}$	$N \leq 0$	7.1" ~1 2.0"	$W \leq 0.07\text{mm}$	—	忽略不計(Ignore)	$0.07\text{mm} < W \leq 0.1\text{mm}$	$L \leq 5\text{mm}$	$N \leq 5$	$W > 0.1\text{mm}$	$L > 5\text{mm}$	$N \leq 0$	次缺 (Min)								
尺寸 (Size)	判定標準(Judging standard)			允收數量 (Acceptance(Q'ty))																																	
	W	L																																			
1.44" ~ 7.0"	$W \leq 0.01\text{mm}$	—	忽略不計(Ignore)																																		
	$0.01\text{mm} < W \leq 0.05\text{mm}$	$L \leq 5\text{mm}$	$N \leq 4$																																		
	$W > 0.05\text{mm}$	$L > 5\text{mm}$	$N \leq 0$																																		
7.1" ~1 2.0"	$W \leq 0.07\text{mm}$	—	忽略不計(Ignore)																																		
	$0.07\text{mm} < W \leq 0.1\text{mm}$	$L \leq 5\text{mm}$	$N \leq 5$																																		
	$W > 0.1\text{mm}$	$L > 5\text{mm}$	$N \leq 0$																																		
6	POL 氣泡(Polarizer Bubble)	<table border="1" data-bbox="528 1503 1276 2018"> <thead> <tr> <th>視區(area)</th> <th>判定標準(Judging standard)</th> <th>允收數量 (Acceptance(Q'ty))</th> </tr> </thead> <tbody> <tr> <td rowspan="4">A 區(Viewing area)</td> <td>$D < 0.2 \text{ mm}$</td> <td>忽略不計(Ignore)</td> </tr> <tr> <td>$0.2\text{mm} < D \leq 0.3\text{mm}$</td> <td>$N \leq 3$</td> </tr> <tr> <td>$0.3\text{mm} < D \leq 0.5\text{mm}$</td> <td>$N \leq 1$</td> </tr> <tr> <td>$0.5\text{mm} < D$</td> <td>$N \leq 0$</td> </tr> <tr> <td>B 區(Outside of viewing area)</td> <td>—</td> <td>忽略不計(Ignore)</td> </tr> </tbody> </table>	視區(area)	判定標準(Judging standard)	允收數量 (Acceptance(Q'ty))	A 區(Viewing area)	$D < 0.2 \text{ mm}$	忽略不計(Ignore)	$0.2\text{mm} < D \leq 0.3\text{mm}$	$N \leq 3$	$0.3\text{mm} < D \leq 0.5\text{mm}$	$N \leq 1$	$0.5\text{mm} < D$	$N \leq 0$	B 區(Outside of viewing area)	—	忽略不計(Ignore)	次缺 (Min)																			
視區(area)	判定標準(Judging standard)	允收數量 (Acceptance(Q'ty))																																			
A 區(Viewing area)	$D < 0.2 \text{ mm}$	忽略不計(Ignore)																																			
	$0.2\text{mm} < D \leq 0.3\text{mm}$	$N \leq 3$																																			
	$0.3\text{mm} < D \leq 0.5\text{mm}$	$N \leq 1$																																			
	$0.5\text{mm} < D$	$N \leq 0$																																			
B 區(Outside of viewing area)	—	忽略不計(Ignore)																																			

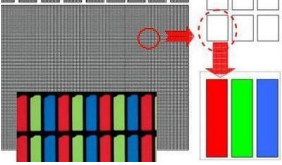
項次 (No)	檢驗項目(Inspection item)	檢驗標準(Inspection Standard)	缺陷等級 (Defect Level)																																																	
7	POL 折痕&分層(The folding and peeled off in polarizer)	偏光片不可有折痕和分層（脫膠）的現象(The folding and peeled off in polarizer are not acceptable).	次缺 (Min)																																																	
8	輝度及均勻性、色度 (Brightness and uniformity、Chroma)	應符合規範或圖紙要求規格(Shall be in accordance with the drawings and specification requirements specifications).	主缺 (Maj)																																																	
9	電性測試 (Electrical Testing)	1.顯示缺畫(Missing line character and icon). 2.無功能與無顯示(No function or no display). 3.顯示故障(Display malfunction). 4.LCD 視角缺陷(LCD viewing angle defect). 5.消耗電流超出規格(Current consumption exceeds product specifications).	主缺 (Maj)																																																	
10	亮點、暗點(Bright dot、Dark dot)On-display Pixel : 3 dot in 1 pixel 	<table border="1"> <thead> <tr> <th>尺寸 (Size)</th> <th>Item</th> <th>判定標準(Judging standard)</th> <th>允收數量 (Acceptance(Q'ty))</th> </tr> </thead> <tbody> <tr> <td rowspan="4">1.44" ~ 4.9"</td> <td rowspan="2">Bright dot</td> <td>$D \leq 1/2 \text{ Pixel}$</td> <td>忽略不計(Ignore)</td> </tr> <tr> <td>$1/2 \text{ Pixel} < D \leq 1 \text{ Pixel}$</td> <td>$N \leq 1$</td> </tr> <tr> <td rowspan="2">Dark dot</td> <td>$D \leq 1/2 \text{ Pixel}$</td> <td>忽略不計(Ignore)</td> </tr> <tr> <td>$1/2 \text{ Pixel} < D \leq 1 \text{ Pixel}$</td> <td>$N \leq 2$</td> </tr> <tr> <td colspan="3">Total</td> <td>$N \leq 2$</td> </tr> <tr> <td rowspan="4">5.0" ~7 .0"</td> <td rowspan="2">Bright dot</td> <td>$D \leq 1/2 \text{ Pixel}$</td> <td>忽略不計(Ignore)</td> </tr> <tr> <td>$1/2 \text{ Pixel} < D \leq 1 \text{ Pixel}$</td> <td>$N \leq 2$</td> </tr> <tr> <td rowspan="2">Dark dot</td> <td>$D \leq 1/2 \text{ Pixel}$</td> <td>忽略不計(Ignore)</td> </tr> <tr> <td>$1/2 \text{ Pixel} < D \leq 1 \text{ Pixel}$</td> <td>$N \leq 3$</td> </tr> <tr> <td colspan="3">Total</td> <td>$N \leq 4$</td> </tr> <tr> <td rowspan="4">7.1" ~1 2.0"</td> <td rowspan="2">Bright dot</td> <td>$D \leq 1/2 \text{ Pixel}$</td> <td>忽略不計(Ignore)</td> </tr> <tr> <td>$1/2 \text{ Pixel} < D \leq 1 \text{ Pixel}$</td> <td>$N \leq 3$</td> </tr> <tr> <td rowspan="2">Dark dot</td> <td>$D \leq 1/2 \text{ Pixel}$</td> <td>忽略不計(Ignore)</td> </tr> <tr> <td>$1/2 \text{ Pixel} < D \leq 1 \text{ Pixel}$</td> <td>$N \leq 4$</td> </tr> <tr> <td colspan="3">Total</td> <td>$N \leq 6$</td> </tr> </tbody> </table>	尺寸 (Size)	Item	判定標準(Judging standard)	允收數量 (Acceptance(Q'ty))	1.44" ~ 4.9"	Bright dot	$D \leq 1/2 \text{ Pixel}$	忽略不計(Ignore)	$1/2 \text{ Pixel} < D \leq 1 \text{ Pixel}$	$N \leq 1$	Dark dot	$D \leq 1/2 \text{ Pixel}$	忽略不計(Ignore)	$1/2 \text{ Pixel} < D \leq 1 \text{ Pixel}$	$N \leq 2$	Total			$N \leq 2$	5.0" ~7 .0"	Bright dot	$D \leq 1/2 \text{ Pixel}$	忽略不計(Ignore)	$1/2 \text{ Pixel} < D \leq 1 \text{ Pixel}$	$N \leq 2$	Dark dot	$D \leq 1/2 \text{ Pixel}$	忽略不計(Ignore)	$1/2 \text{ Pixel} < D \leq 1 \text{ Pixel}$	$N \leq 3$	Total			$N \leq 4$	7.1" ~1 2.0"	Bright dot	$D \leq 1/2 \text{ Pixel}$	忽略不計(Ignore)	$1/2 \text{ Pixel} < D \leq 1 \text{ Pixel}$	$N \leq 3$	Dark dot	$D \leq 1/2 \text{ Pixel}$	忽略不計(Ignore)	$1/2 \text{ Pixel} < D \leq 1 \text{ Pixel}$	$N \leq 4$	Total			$N \leq 6$	次缺 (Min)
尺寸 (Size)	Item	判定標準(Judging standard)	允收數量 (Acceptance(Q'ty))																																																	
1.44" ~ 4.9"	Bright dot	$D \leq 1/2 \text{ Pixel}$	忽略不計(Ignore)																																																	
		$1/2 \text{ Pixel} < D \leq 1 \text{ Pixel}$	$N \leq 1$																																																	
	Dark dot	$D \leq 1/2 \text{ Pixel}$	忽略不計(Ignore)																																																	
		$1/2 \text{ Pixel} < D \leq 1 \text{ Pixel}$	$N \leq 2$																																																	
Total			$N \leq 2$																																																	
5.0" ~7 .0"	Bright dot	$D \leq 1/2 \text{ Pixel}$	忽略不計(Ignore)																																																	
		$1/2 \text{ Pixel} < D \leq 1 \text{ Pixel}$	$N \leq 2$																																																	
	Dark dot	$D \leq 1/2 \text{ Pixel}$	忽略不計(Ignore)																																																	
		$1/2 \text{ Pixel} < D \leq 1 \text{ Pixel}$	$N \leq 3$																																																	
Total			$N \leq 4$																																																	
7.1" ~1 2.0"	Bright dot	$D \leq 1/2 \text{ Pixel}$	忽略不計(Ignore)																																																	
		$1/2 \text{ Pixel} < D \leq 1 \text{ Pixel}$	$N \leq 3$																																																	
	Dark dot	$D \leq 1/2 \text{ Pixel}$	忽略不計(Ignore)																																																	
		$1/2 \text{ Pixel} < D \leq 1 \text{ Pixel}$	$N \leq 4$																																																	
Total			$N \leq 6$																																																	